

INTERNATIONAL STANDARD

**ISO
1518-2**

First edition
2011-10-15

Paints and varnishes — Determination of scratch resistance —

Part 2: Variable-loading method

*Peintures et vernis — Détermination de la résistance à la rayure —
Partie 2: Méthode à charge variable*

Licensed by SOURCE to ISO/TC35/SC9
Downloaded: 2011-11-11
Single-user licence only, copying and networking prohibited.



Reference number
ISO 1518-2:2011(E)

© ISO 2011

标格达仪器
www.biuged.com

标格达仪器
www.biuged.com

标格达仪器
www.biuged.com

标格达仪器
www.biuged.com

标格达仪器
www.biuged.com

标格达仪器
www.biuged.com

标格达仪器
www.biuged.com

标格达仪器
www.biuged.com

标格达仪器
www.biuged.com

标格达仪器
www.biuged.com



COPYRIGHT PROTECTED DOCUMENT

License by SOURCE to ISO/TC35/SC9
Uploaded: 2011-11-11
Single-user licence only. Copying and networking prohibited.

© ISO 2011

All rights reserved. Unless otherwise specified, no part of this publication may be reproduced or utilized in any form or by any means, electronic or mechanical, including photocopying and microfilm, without permission in writing from either ISO at the address below or ISO's member body in the country of the requester.

ISO copyright office
Case postale 56 • CH-1211 Geneva 20
Tel. + 41 22 749 01 11
Fax + 41 22 749 09 47
E-mail copyright@iso.org
Web www.iso.org

Published in Switzerland

Foreword

ISO (the International Organization for Standardization) is a worldwide federation of national standards bodies (ISO member bodies). The work of preparing International Standards is normally carried out through ISO technical committees. Each member body interested in a subject for which a technical committee has been established has the right to be represented on that committee. International organizations, governmental and non-governmental, in liaison with ISO, also take part in the work. ISO collaborates closely with the International Electrotechnical Commission (IEC) on all matters of electrotechnical standardization.

International Standards are drafted in accordance with the rules given in the ISO/IEC Directives, Part 2.

The main task of technical committees is to prepare International Standards. Draft International Standards adopted by the technical committees are circulated to the member bodies for voting. Publication as an International Standard requires approval by at least 75 % of the member bodies casting a vote.

Attention is drawn to the possibility that some of the elements of this document may be the subject of patent rights. ISO shall not be held responsible for identifying any or all such patent rights.

ISO 1518-2 was prepared by Technical Committee ISO/TC 35, *Paints and varnishes*, Subcommittee SC 9, *General test methods for paints and varnishes*.

It cancels and replaces ISO 12137-2:1997, which has been technically revised.

The main changes are the following:

- a) The number of the standard has been changed from ISO 12137-2 to ISO 1518-2 in order to group the scratch-resistance tests under the same number (ISO 1518).
- b) A definition of scratch has been introduced.
- c) The supplementary test conditions (formerly Annex A) have been integrated in the test report.
- d) The text has been editorially revised and the normative references have been updated.

ISO 1518 consists of the following parts, under the general title *Paints and varnishes — Determination of scratch resistance*:

- *Part 1: Constant-loading method*
- *Part 2: Variable-loading method*

Licensed by SOURCE to ISO/TC35/SC9
Downloaded: 2011-11-11
Single-user licence only, copying and networking prohibited.

标格达仪器
www.biuged.com

Licensed by SOURCE to ISO/TC35/SC9
Downloaded: 2011-11-11
Single-user licence only, copying and networking prohibited.

Paints and varnishes — Determination of scratch resistance —

Part 2: Variable-loading method

1 Scope

This part of ISO 1518 specifies a method for determining, using a pointed stylus loaded with a continuously increasing load, the scratch resistance of a single coating of a paint, varnish or related product, or the upper layer of a multicoat system.

This test has been found to be useful in comparing the scratch resistance of different coatings. It is most useful in providing relative ratings for a series of coated panels exhibiting significant differences in scratch resistance.

Neither this part of ISO 1518 nor ISO 1518-1 specifies a method using a curved stylus, which is specified in ISO 12137. The choice between the three methods will depend on the particular practical problem.

2 Normative references

The following referenced documents are indispensable for the application of this document. For dated references, only the edition cited applies. For undated references, the latest edition of the referenced document (including any amendments) applies.

ISO 1513, *Paints and varnishes — Examination and preparation of test samples*

ISO 1514, *Paints and varnishes — Standard panels for testing*

ISO 2808, *Paints and varnishes — Determination of film thickness*

ISO 15528, *Paints, varnishes and raw materials for paints and varnishes — Sampling*

3 Terms and definitions

For the purposes of this document, the following terms and definitions apply.

3.1

scratch, n

cut or gouge through the surface of a coating, made by contact with a sharp object

4 Principle

The product or system under test is applied at uniform thickness to flat panels of uniform surface texture. After drying/curing, the scratch resistance is determined using an automatic instrument which pushes the panels beneath a pointed stylus mounted so that it presses down perpendicularly on the surface of the test panel. The load on the test panel is increased continuously until the coating is scratched.

5 Apparatus

5.1 Instrument for determining scratch resistance.

A suitable instrument¹⁾ is shown in Figure 1. It consists principally of a counterbalanced beam with, mounted at one end, a pointed stylus. The test panel is placed on a sliding table which is motor-driven to move under the stylus at a speed of 10 mm/s. A continuous-loading weight mounted over the beam acts on the beam in such a way that, as the test panel passes under the stylus, the load on the stylus is continuously increased.

The stylus-loading range can be varied by changing the continuous-loading weight (weights giving loading ranges of 0 g to 50 g, 0 g to 100 g and 0 g to 200 g are available, for instance). Mounted over the stylus itself is a small scale pan on which weights can be placed to expand the stylus-loading range (adding a weight of 100 g, for instance, changes a 0 g to 200 g loading range to one of 100 g to 300 g).

Licensed by SOURCE to ISO/TC35/SC9
Downloaded: 2011-11-11
Single-user licence only, copying and networking prohibited.

1) This apparatus is available from Shinto Scientific Co., Ltd, 27 Kanda-higashikonyacho, Chiyoda-ku, Tokyo 101-0034, Japan. This information is given for the convenience of users of this part of ISO 1518 and does not constitute endorsement by ISO of the apparatus shown. Other types of scratch tester may be used if they can be shown to give similar relative ratings.

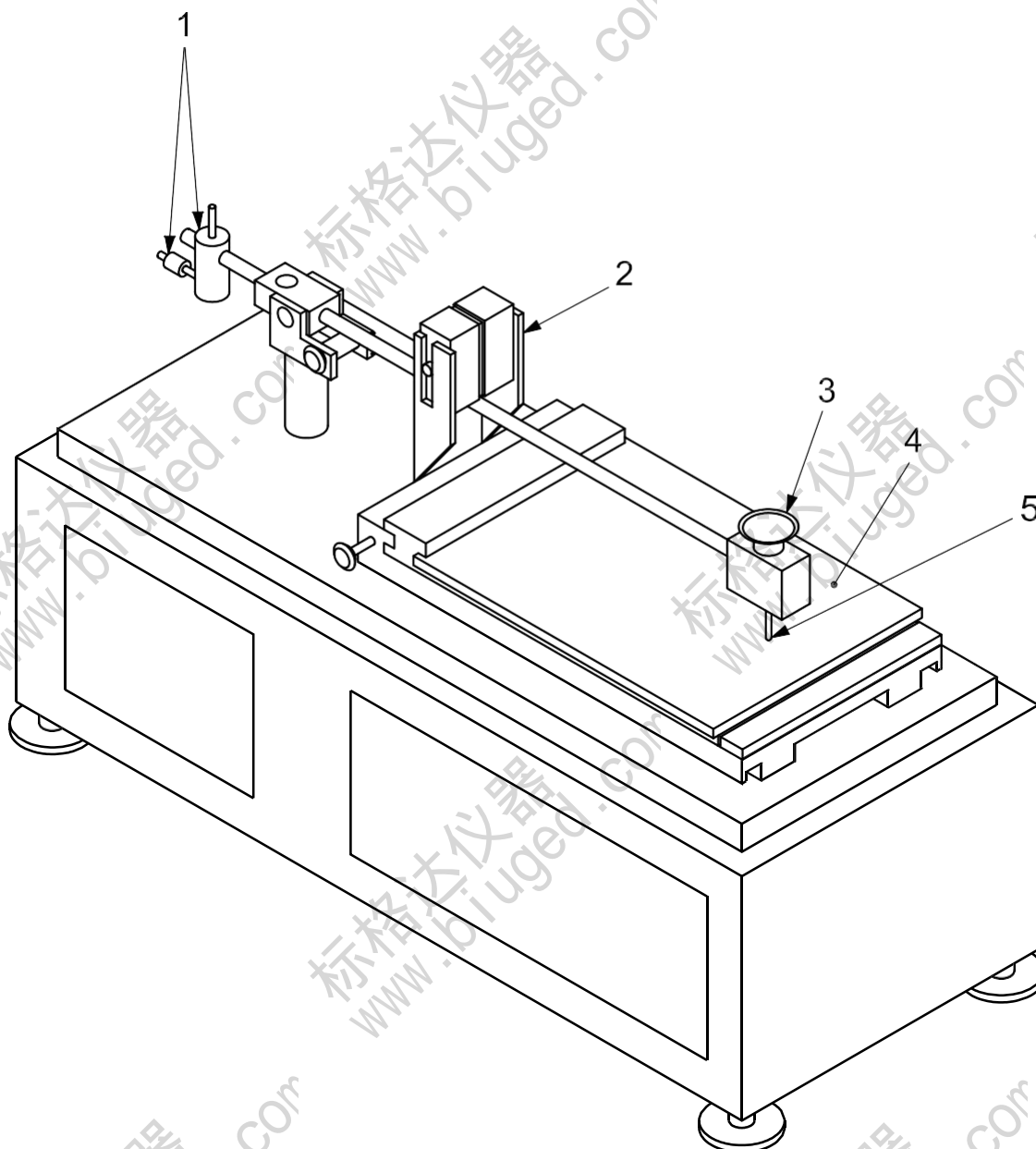
**Key**

- 1 cylindrical counterweight
- 2 continuous-loading weight
- 3 scale pan
- 4 sliding table
- 5 stylus

Figure 1 — Scratch instrument with pointed stylus

5.2 Stylus, preferably tipped with a conical sapphire or diamond, the point of which is rounded to a radius of $(0,03 \pm 0,005)$ mm (see Figure 2).

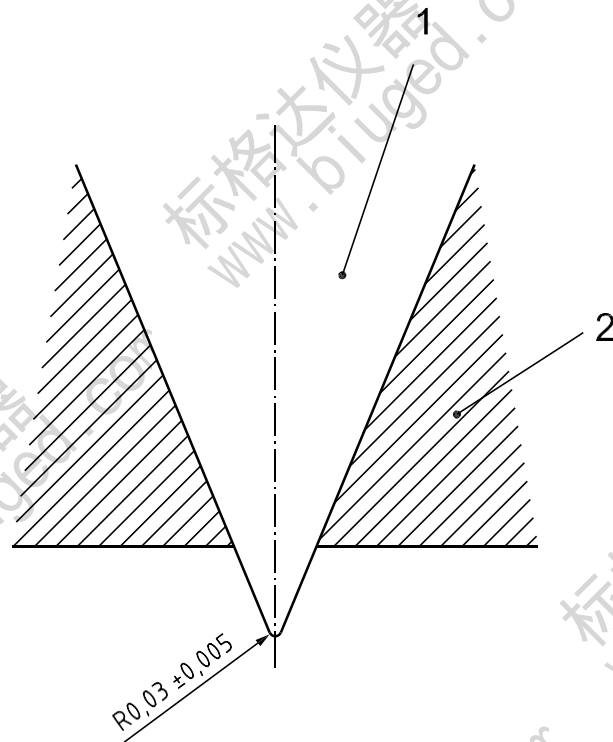

Key

- 1 conical sapphire or diamond
- 2 stylus

Figure 2 — Stylus tipped with conical sapphire or diamond

5.3 Microscope, preferably with a magnification range extending up to $\times 100$, required to examine the stylus. It may also be used to inspect the scratched coating.

6 Sampling

Take a representative sample of the product to be tested (or of each product in the case of a multicoat system), as specified in ISO 15528.

Examine and prepare each sample for testing, as specified in ISO 1513.

7 Test panels

7.1 Substrate

Select the substrate from one of those specified in ISO 1514 and, where possible, in accordance with the desired practical application. The panels shall be plane and free from distortion, with a maximum thickness of about 12 mm, and 100 mm to 400 mm wide and long.

7.2 Preparation and coating

Prepare each test panel in accordance with ISO 1514 and then coat it by the specified method with the product or system under test.

7.3 Drying and conditioning

Dry (or stove) and age, if applicable, each coated test panel according to the instructions given for the product or system under test. Before testing, condition the coated panels at $(23 \pm 2) ^\circ\text{C}$ and a relative humidity of $(50 \pm 5) \%$ for a minimum period of 16 h.

The coated panels shall be stored and handled so as to avoid contamination by fingerprints and dust.

NOTE Fingerprints, dust or other contamination on the surface will result in a lower accuracy.

7.4 Thickness of coating

Determine the thickness, in micrometres, of the dried coating by one of the procedures specified in ISO 2808.

8 Procedure

8.1 Test conditions

Carry out the test at $(23 \pm 2) ^\circ\text{C}$ and a relative humidity of $(50 \pm 5) \%$.

8.2 Preparation for the test

Place the instrument on a stable and level surface.

Level the instrument in accordance with the manufacturer's instructions.

Examine the stylus under the microscope, preferably at a magnification of $\times 100$, in accordance with the instrument operation manual, to ensure that it is undamaged.

Clean the stylus, if necessary, with a clean cloth or lint-free paper.

8.3 Determination

Place a test panel up against the stop on the sliding table. Secure the panel in place by turning the securing screws evenly about one turn at a time.

Secure the stylus in the vertical position.

Adjust the counterweights so that, when the tip of the stylus is just touching the surface of the test panel, the load on the stylus is zero.

Adjust the height of the stylus to the thickness of the test panel, with the beam released and the stylus resting on the test panel.

Load the stylus at the lowest weight range to be tested, e.g. 0 g to 50 g.

Start the instrument at a rate of about 10 mm/s. The instrument shown in Figure 1 will stop automatically when the sliding table has moved 100 mm.

Inspect the coating for scratching under a suitable magnification or with the naked eye.

If no scratching occurs, increase the stylus-loading range, e.g. 0 g to 100 g, and continue in test areas that do not overlap until scratching does occur. When scratching has occurred, determine which type of defect is involved. The defects are defined as follows:

- a) Plastic deformation: the permanent indentation of the surface with or without any surface blemish or cohesive fracture.
- b) Surface blemish: a superficial surface effect caused by a difference in the scattering of light between the line of test and the adjacent surface.
- c) Surface scratch: a continuous cut or gouge through the surface.
- d) Cohesive fracture: the presence of a visible surface break or rupture.
- e) Combinations of the above.

NOTE In some cases, one of these types of defect might be of particular importance.

Repeat the determination at least twice (i.e. for a total of at least three determinations) on the same panel at the stylus-loading range at which scratching occurs.

For each of the determinations, measure the distance d , in millimetres, from the final-loading point (i.e. the point where the stylus stops moving) to the point where scratching occurs.

9 Expression of results

For each of the determinations carried out, calculate the critical load, F_c , expressed in grams, at the point at which scratching just occurs, using Equation (1):

$$F_c = \frac{100 - d}{100} \times (F_f - F_i) \quad (1)$$

where

d is the distance, expressed in millimetres, from the final-loading point to the point where scratching just occurs;

F_f is the final load, expressed in grams, in the stylus-loading range selected;

F_i is the initial load, expressed in grams, in the stylus-loading range selected.

NOTE Some instruments use a scratch-intensity recorder to determine the load which causes scratching of the paint film.

Calculate the mean critical load for the three determinations made on the test panel. Report the result to the nearest 1 g.

10 Precision

No relevant precision data are currently available.

11 Test report

The test report shall contain at least the following information:

- a) all details necessary to identify the product tested;
- b) a reference to this part of ISO 1518 (ISO 1518-2:2011);
- c) all details on preparation of the test panels, including
 - 1) the material (including thickness) and surface preparation of the substrate (see 7.1 and 7.2),
 - 2) the method of application of the test coating to the substrate (see 7.2),
 - 3) the duration and conditions of drying (or stoving) and ageing (if applicable) of the coating before testing (see 7.3),
 - 4) the thickness, in micrometres, of the dry coating and method of measurement in accordance with ISO 2808, and whether it is a single coating or a multicoated system (see 7.4);
- d) the temperature and relative humidity during the test, if different from those specified in 8.1;
- e) the type of apparatus used;
- f) the dimensions of the stylus used;
- g) whether scratching was assessed using the naked eye or a microscope and, if a microscope was used, the magnification setting at which it was used;
- h) the test results:
 - 1) a description of those of the elements of scratching defined in 8.3 which actually occurred (not all will necessarily occur),
 - 2) the mean critical load, expressed in grams, at which each of these elements of scratching occurred, as specified in Clause 9;
- i) any deviation from the test method specified;
- j) any unusual features (anomalies) observed during the test;
- k) the date of the test.

Licensed by SOURCE to ISO/TC35/SC9
Downloaded: 2011-11-11
Single-user licence only, copying and networking prohibited.

Bibliography

- [1] ISO 1518-1, *Paints and varnishes — Determination of scratch resistance — Part 1: Constant-loading method*
- [2] ISO 12137, *Paints and varnishes — Determination of mar resistance*

Licensed by SOURCE to ISO/TC35/SC9
Downloaded: 2011-11-11
Single-user licence only, copying and networking prohibited.

标格达仪器
www.biuged.com

Licensed by SOURCE to ISO/TC35/SC9
Downloaded: 2011-11-11
Single-user licence only, copying and networking prohibited.

Licensed by SOURCE to ISO/TC35/SC9
Downloaded: 2011-11-11
Single-user licence only, copying and networking prohibited.

ICS 87.040

Price based on 8 pages