

INTERNATIONAL  
STANDARD

ISO  
4624

Third edition  
2016-03-01

---

---

**Paints and varnishes — Pull-off test  
for adhesion**

*Peintures et vernis — Essai de traction*



Reference number  
ISO 4624:2016(E)

© ISO 2016

标格达仪器  
www.biuged.com

标格达仪器  
www.biuged.com

标格达仪器  
www.biuged.com

标格达仪器  
www.biuged.com

标格达仪器  
www.biuged.com

标格达仪器  
www.biuged.com

标格达仪器  
www.biuged.com



**COPYRIGHT PROTECTED DOCUMENT**

© ISO 2016, Published in Switzerland

All rights reserved. Unless otherwise specified, no part of this publication may be reproduced or utilized otherwise in any form or by any means, electronic or mechanical, including photocopying, or posting on the internet or an intranet, without prior written permission. Permission can be requested from either ISO at the address below or ISO's member body in the country of the requester.

ISO copyright office  
Ch. de Blandonnet 8 • CP 401  
CH-1214 Vernier, Geneva, Switzerland  
Tel. +41 22 749 01 11  
Fax +41 22 749 09 47  
copyright@iso.org  
www.iso.org

标格达仪器  
www.biuged.com

# Contents

	Page
Foreword .....	iv
Introduction .....	v
<b>1 Scope</b> .....	<b>1</b>
<b>2 Normative references</b> .....	<b>1</b>
<b>3 Principle</b> .....	<b>1</b>
<b>4 Apparatus</b> .....	<b>2</b>
<b>5 Adhesives</b> .....	<b>4</b>
<b>6 Sampling</b> .....	<b>4</b>
<b>7 Test panels</b> .....	<b>5</b>
7.1 Substrate .....	5
7.2 Preparation and coating .....	5
7.3 Drying and conditioning .....	5
7.4 Thickness of coating .....	5
<b>8 Procedure</b> .....	<b>5</b>
8.1 Number of determinations .....	5
8.2 Ambient conditions .....	5
8.3 Adhesive .....	5
8.4 Test assemblies .....	5
8.4.1 Method A: General method (using two dollies) for testing both rigid and deformable substrates .....	5
8.4.2 Method B: Method for testing from one side only, using a single dolly (suitable for rigid substrates only) .....	6
8.4.3 Method C: Method using dollies, one as a painted substrate .....	7
8.5 Measurement .....	7
8.5.1 Breaking strength .....	7
8.5.2 Nature of the fracture .....	8
<b>9 Calculation and expression of results</b> .....	<b>8</b>
9.1 Breaking strength .....	8
9.2 Nature of failure .....	9
9.3 Example .....	9
<b>10 Precision</b> .....	<b>9</b>
<b>11 Test report</b> .....	<b>9</b>
<b>Bibliography</b> .....	<b>11</b>

## Foreword

ISO (the International Organization for Standardization) is a worldwide federation of national standards bodies (ISO member bodies). The work of preparing International Standards is normally carried out through ISO technical committees. Each member body interested in a subject for which a technical committee has been established has the right to be represented on that committee. International organizations, governmental and non-governmental, in liaison with ISO, also take part in the work. ISO collaborates closely with the International Electrotechnical Commission (IEC) on all matters of electrotechnical standardization.

The procedures used to develop this document and those intended for its further maintenance are described in the ISO/IEC Directives, Part 1. In particular the different approval criteria needed for the different types of ISO documents should be noted. This document was drafted in accordance with the editorial rules of the ISO/IEC Directives, Part 2 (see [www.iso.org/directives](http://www.iso.org/directives)).

Attention is drawn to the possibility that some of the elements of this document may be the subject of patent rights. ISO shall not be held responsible for identifying any or all such patent rights. Details of any patent rights identified during the development of the document will be in the Introduction and/or on the ISO list of patent declarations received (see [www.iso.org/patents](http://www.iso.org/patents)).

Any trade name used in this document is information given for the convenience of users and does not constitute an endorsement.

For an explanation on the meaning of ISO specific terms and expressions related to conformity assessment, as well as information about ISO's adherence to the WTO principles in the Technical Barriers to Trade (TBT) see the following URL: [Foreword - Supplementary information](#)

The committee responsible for this document is ISO/TC 35, *Paints and varnishes*, Subcommittee SC 9, *General test methods for paints and varnishes*.

This third edition cancels and replaces the second edition (ISO 4624:2002), which has been technically revised with the following changes:

- a) detailed information on how to avoid distortion of the substrate during the tensile test has been added;
- b) the three methods using one dolly or two dollies on a painted panel and two dollies, one as painted substrate, have been named methods A, B and C;
- c) the supplementary test conditions previously in Annex A have been integrated in the test report.



## Introduction

This International Standard is one of two standards which describe methods for assessing the adhesion of a single coating or a multi-coat system of paint, varnish or related product by measuring the minimum tensile stress necessary to detach or to rupture the coating in a direction perpendicular to the substrate.

The test result is influenced not only by the mechanical properties of the system under test, but also by the nature and preparation of the substrate, the method of paint application, the drying conditions of the coating, the temperature, the humidity and other factors like the type of test instrument which has been used.

One other International Standard for the evaluation of adhesion characteristics is ISO 2409.

.com

标格达仪器  
www.biuged.com

标格达仪器  
www.biuged.com

标格达仪器  
www.biuged.com

标格达仪器  
www.biuged.com

标格达仪器  
www.biuged.com

标格达仪器  
www.biuged.com

标格达仪器  
www.biuged.com

标格达仪器  
www.biuged.com

标格达仪器  
www.biuged.com

标格达仪器  
www.biuged.com

# Paints and varnishes — Pull-off test for adhesion

## 1 Scope

This International Standard specifies three methods (i.e. one dolly or two dollies on a painted panel and two dollies, one as painted substrate) for determining the adhesion by carrying out a pull-off test on a single coating or a multi-coat system of paint, varnish or related product.

These test methods have been found useful in comparing the adhesion behaviour of different coatings. It is most useful in providing relative ratings for a series of coated panels exhibiting significant differences in adhesion.

The test may be applied using a wide range of substrates. Different procedures are given according to whether the substrate is deformable, for example thin metal, plastics and wood, or rigid, for example thick concrete and metal plates. To avoid distortion of the substrate during the tensile test, it is common to use a sandwich construction. For example, for special purposes, the coating may be applied directly to the face of a test dolly.

## 2 Normative references

The following documents, in whole or in part, are normatively referenced in this document and are indispensable for its application. For dated references, only the edition cited applies. For undated references, the latest edition of the referenced document (including any amendments) applies.

ISO 1513, *Paints and varnishes — Examination and preparation of test samples*

ISO 1514, *Paints and varnishes — Standard panels for testing*

ISO 2808, *Paints and varnishes — Determination of film thickness*

ISO 3270, *Paints and varnishes and their raw materials — Temperatures and humidities for conditioning and testing*

ISO 15528, *Paints, varnishes and raw materials for paints and varnishes — Sampling*

## 3 Principle

The product or system under test is applied at uniform thickness to flat panels of uniform surface texture.

After drying/curing the coating system, dollies are bonded directly to the surface of the coated, cured panel using an adhesive.

After curing of the adhesive, the bonded dolly assemblies are placed in a suitable tensile tester. The bonded assemblies are subjected to a controlled tensile test (pull-off test), and the force required to break the coating/substrate bond is measured.

To avoid possible distortion of the substrate during the tensile test, dollies with a diameter smaller than the 2 cm diameter used for steel substrates may be used to reduce the force introduced.

The test result is the tensile stress necessary to break the weakest interface (adhesive failure) or the weakest component (cohesive failure) of the test assembly. Mixed adhesive/cohesive failures may also occur.

## 4 Apparatus

**4.1 Tensile tester**, suitable for carrying out the chosen procedure specified in [Clause 8](#). The tensile stress shall be applied in a direction perpendicular to the plane of the coated substrate and shall be increased at a substantially uniform rate, not greater than 1 MPa/s<sup>1)</sup> such that failure of the test assembly occurs within 90 s. Suitable designs for applying the tensile stress are shown in [Figures 1](#) and [2](#).

Instead of a tensile tester, other types of pull-off adhesion testers (mechanically, pneumatically, hydraulically or hand-driven) may be used provided that they give similar results. The type of instrument shall be reported in the test report, because hand-driven/mechanical/hydraulic instruments are reported to produce widely different results.

**NOTE** The results can be influenced by the test assembly used. Furthermore, the results are not reproducible unless coaxial alignment of the tensile forces is ensured.

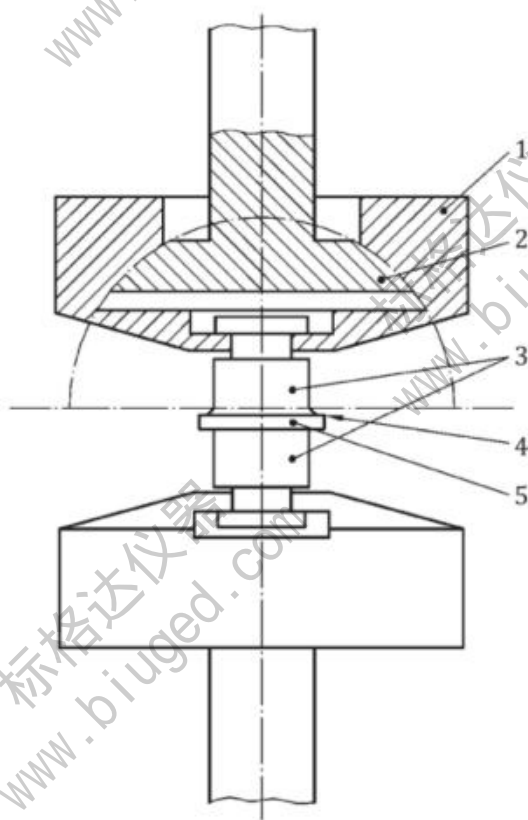

### Key

- 1 support
- 2 ball joint
- 3 dollies
- 4 coating
- 5 substrate

**Figure 1** — Example of a suitable test apparatus for the two-dolly methods described in [8.4.1](#) and [8.4.3](#) (methods A and C)

1) 1 MPa/s = 1 MN/(m<sup>2</sup>·s).

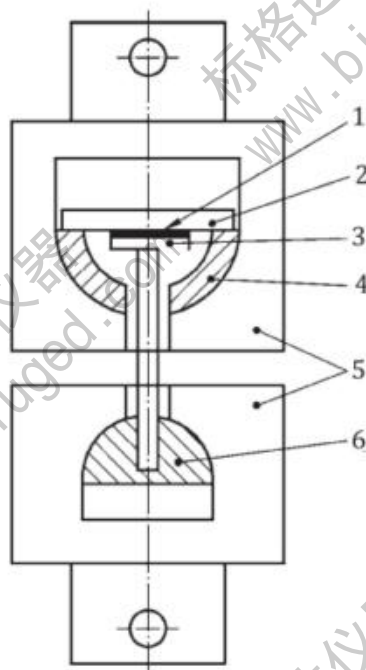

**Key**

- 1 coating
- 2 test piece
- 3 dolly
- 4 ball-and-socket sliding joint
- 5 support (suitably designed to allow for joint assembly)
- 6 ball-and-socket sliding joint

**Figure 2 — Example of a suitable test apparatus for the one-dolly method described in 8.4.2 (method B)**

**4.2 Test dollies**, each consisting of a steel or aluminium cylindrical-faced testing body, specifically designed to be used with the tensile tester. Each dolly has a rigid, flat face for bonding the adhesive/coating at one end and a facility for connecting the pull-off tester at the other. Each dolly has a nominal diameter of 20 mm (see, however, following paragraph) and sufficient thickness to ensure freedom from distortion during the test. It is recommended that the length of each dolly is not less than half its diameter. The faces of each dolly shall be machined perpendicular to its axis before use.

Dollies with a diameter of, for example, 7 mm may be used when the method for testing adhesion from one side only is used and when there is a danger of distortion of the substrate (see 8.4.2). If dollies smaller in diameter are used, more measurements shall be made to improve the precision. When using 7 mm dollies, 10 measurements have been shown to be practicable. The diameter of the dollies shall be reported in the test report.

**4.3 Centering device**, for ensuring proper coaxial alignment of the test assembly during the adhesion process of the two-dolly methods described in 8.4.1 (method A) and 8.4.3 (method C). A suitable design is shown in Figure 3.

**4.4 Cutting device**, such as a sharp knife, for cutting through cured adhesive and the paint coating to the substrate, round the circumference of the dolly.

Depending on the mechanical properties of the paint system (e.g. brittleness), cutting through the cured adhesive and the paint film to the substrate can have a big influence on the adhesion of the paint system. It is permitted, if specified or agreed between the interested parties, not to cut when the paint

systems are less than 150 µm in layer thickness. If cuts around the dolly have been made, this shall be mentioned in the test report and the type of cutting tool shall also be mentioned.

When using small dollies, cutting often is difficult and is normally not carried out. Experience has shown that an increasing number of small dollies has an advantage concerning precision compared to the cut combined with the 20 mm dollies.

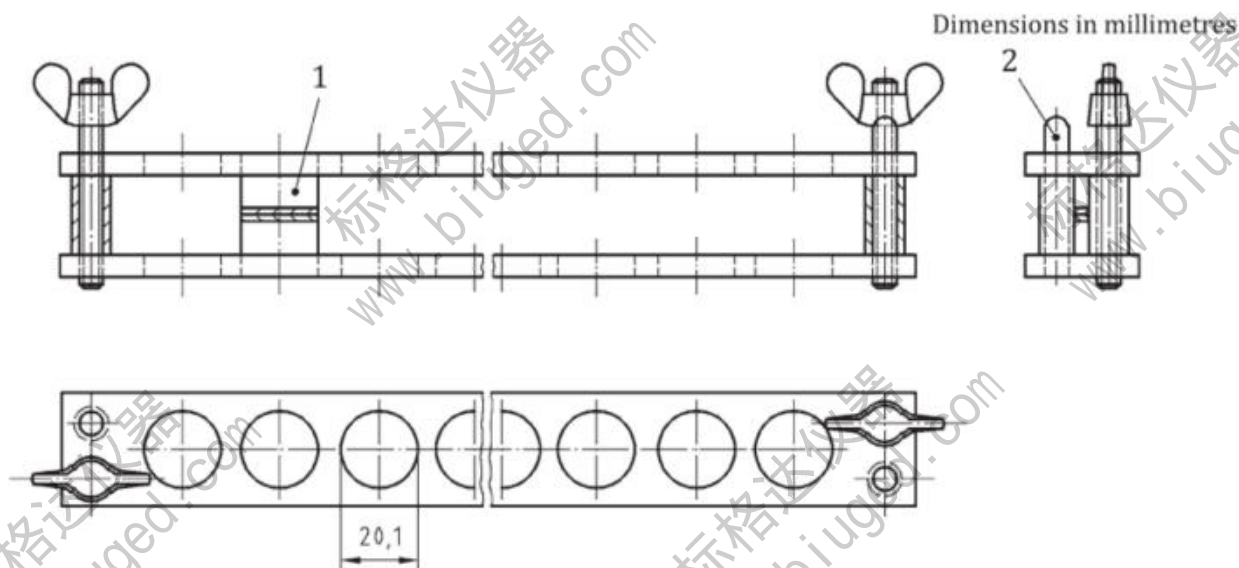

- Key**
- 1 test assembly aligned for adhesion process (see 4.3)
  - 2 centering pin

**Figure 3 — Example of a suitable centering device for 20 mm-diameter dollies**

## 5 Adhesives

Special attention is required in selecting suitable adhesives to be used in the test. To produce failure of the coating, it is essential that the cohesive and bonding properties of the adhesive are greater than those of the coating under test.

Preliminary screening of adhesives shall be carried out in order to determine their suitability for use. Suitable adhesives and, if applicable, their unmixed components shall cause little or no visible change in the coating under test when left in contact with the coating for a period equivalent to the curing time of the adhesive.

Adhesives which give the highest results, which means the most coating-substrate adhesive failure or coating failure, are preferred.

In most cases, cyanoacrylate, two-component solventless epoxide and peroxide-catalysed polyester adhesives have been found suitable. In special tests under highly humid conditions, the curing time of the adhesive should be as short as possible. The use of two-pack quick-drying epoxy adhesive is preferable in these situations.

Where failure is mainly associated with the adhesive at tensions less than 5 MPa, the use of another type of adhesive may enable more useful results to be obtained.

## 6 Sampling

Take a representative sample of the product to be tested (or of each product in case of a multi-coat system), as specified in ISO 15528.



Examine and prepare the sample for testing, as specified in ISO 1513.

## 7 Test panels

### 7.1 Substrate

Select the substrate from one of those described in ISO 1514, using where possible the same type of material as will be used in practice. The substrate panels shall be plane and free from distortion.

### 7.2 Preparation and coating

Prepare each test panel in accordance with that pretreatment method which is intended to be carried out on the original surface. The chosen pretreatment shall be reported in the test report.

### 7.3 Drying and conditioning

Dry (or stove) and age, if applicable, each coated test panel for the specified time and under the specified conditions. Before testing, condition the coated panels at  $(23 \pm 2)$  °C and a relative humidity of  $(50 \pm 5)$  % (as specified in ISO 3270), for a minimum period of 16 h.

### 7.4 Thickness of coating

The thickness of the coating shall be specified and agreed between the interested parties. Determine the thickness, in micrometres, of the dried coating by one of the procedures specified in ISO 2808.

NOTE See also [Clause 1](#).

## 8 Procedure

### 8.1 Number of determinations

Carry out at least six determinations, i.e. using at least six test assemblies (see [8.4](#)).

### 8.2 Ambient conditions

Carry out the test at  $(23 \pm 2)$  °C and a relative humidity of  $(50 \pm 5)$  %, as specified in ISO 3270.

### 8.3 Adhesive

Prepare and apply the adhesive (see [Clause 5](#)) in accordance with the manufacturer's instructions. Use the minimum quantity of adhesive required to produce a firm, continuous and even bond between the components of the test assembly. Remove any excess adhesive immediately if possible.

### 8.4 Test assemblies

#### 8.4.1 Method A: General method (using two dollies) for testing both rigid and deformable substrates

If the test piece is too large, use an area cut from the coated substrate (disc of minimum diameter 30 mm or square of minimum side 30 mm). Take care not to distort the test piece. Apply the adhesive evenly to the surfaces of two freshly-cleaned dollies ([4.2](#)) of equal diameter.

Place the test piece between the adhesive-coated faces of the dollies such that the dollies are coaxially aligned in the centre of the test piece, as shown in [Figure 4](#). Align the test assembly in the centering device ([4.3](#)) and maintain the alignment for a period equal to the curing time of the adhesive. In special

tests under highly humid conditions, the curing time of the adhesive shall be as short as possible, the use of two-pack quick-drying epoxy adhesive is preferable in these situations. At the end of this period, carefully use the cutting device (4.4) to cut around the circumference of the dollies through to the substrate, unless otherwise specified or agreed (see 4.4).

The adhesion at the adhesive/coating interface may be improved by lightly abrading the surface of the dried coating and the surface of the test dolly before application of the adhesive.

In the method for deformable substrates, if a poor adhesive bond is expected between the uncoated face of the substrate and the dolly, coat both faces of the substrate with the product under test.

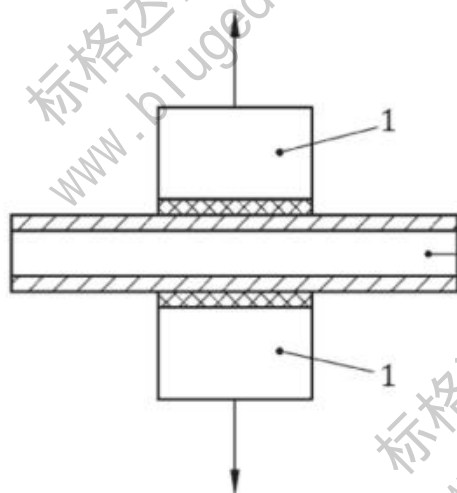

**Key**

- 1 dolly coated with adhesive
- 2 substrate painted on one or both sides

**Figure 4 — Test assembly for sandwich method with substrate painted on one or both sides**

**8.4.2 Method B: Method for testing from one side only, using a single dolly (suitable for rigid substrates only)**

Apply the adhesive evenly to the uncoated, freshly-cleaned surface of a dolly (4.2). Place the adhesive-coated face of the dolly in contact with the coating, for a period equal to the curing time of the adhesive (see 8.4.1). At the end of this period, carefully use the cutting device (4.4) to cut around the circumference of the dolly through to the substrate, unless otherwise specified or agreed.

Place the outer ring in position and test as indicated in Figure 5.

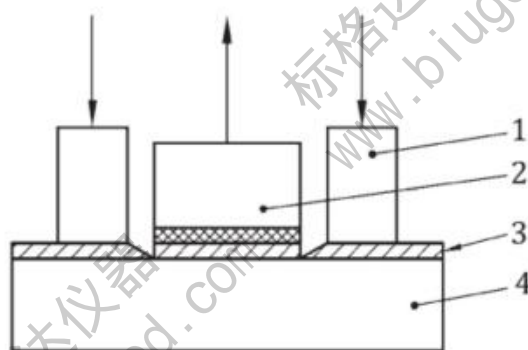

**Key**

- 1 outer ring
- 2 dolly coated with adhesive
- 3 paint coating
- 4 substrate

**Figure 5 — Test assembly for rigid substrates****8.4.3 Method C: Method using dollies, one as a painted substrate**

Apply the adhesive evenly to the uncoated, freshly-cleaned surface of a dolly. Place the adhesive-coated surface of the dolly in contact with the surface of a second dolly coated with the product under test, as shown in [Figure 6](#), and align the test assembly in the centering device ([4.3](#)) for a period equal to the curing time of the adhesive.

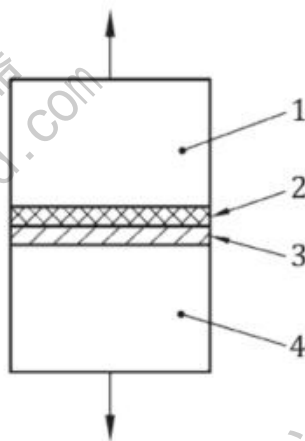
**Key**

- 1 painted dolly
- 2 paint film
- 3 adhesive
- 4 dolly coated with adhesive

**Figure 6 — Test assembly using dollies only****8.5 Measurement****8.5.1 Breaking strength**

Immediately after the period allowed for the curing of the adhesive, place the test assembly in the pull-off adhesion tester ([4.1](#)), taking care to align the dollies so that the tensile force is applied uniformly

across the test area, without any bending moment. Apply a tensile stress, increasing at a rate not greater than 1 MPa/s, perpendicular to the plane of the coated substrate such that failure of the test assembly occurs within 90 s of initial application of the stress.

Record the tensile stress required to break the test assembly. Repeat the pull-off test for each test assembly prepared (see 8.1).

### 8.5.2 Nature of the fracture

Visually inspect the fracture surfaces to establish the nature of the fracture, and assess the type of fracture as follows:

- A is cohesive failure of substrate;
- A/B is adhesive failure between substrate and first coat;
- B is cohesive failure of first coat;
- B/C is adhesive failure between first and second coats;
- n* is cohesive failure of the *n*th coat of a multicoat system;
- n/m* is adhesive failure between the *n*th coat and the *m*th coat of a multicoat system;
- /Y is adhesive failure between final coat and adhesive;
- Y is cohesive failure of adhesive;
- Y/Z is adhesive failure between adhesive and dolly.

Estimate the area of fracture as a percentage to the nearest 10 % for each type of fracture.

Where consistency of bonding failure is not achieved, review both the preparation and application of the coating; for inconsistent failure of the adhesive, see [Clause 5](#) and [8.4.1](#). Repeat the series of tests using at least six more test assemblies.

## 9 Calculation and expression of results

### 9.1 Breaking strength

The breaking strength,  $\sigma$ , in megapascals, for each test assembly is given by Formula (1):

$$\sigma = \frac{F}{A} \tag{1}$$

where

*F* is the breaking force, in newtons;

*A* is the area of the dolly, in square millimetres.

In the case of dollies of diameter 20 mm, the breaking strength, in megapascals, is given by Formula (2)

$$\sigma = \frac{4F}{400\pi} = \frac{F}{314} \tag{2}$$

Calculate the mean of all determinations to the nearest whole number. Express the result as a mean and range.

## 9.2 Nature of failure

Express the result as the estimated mean percentage area and type of fracture in the system under test in accordance with [8.5.2](#).

## 9.3 Example

If a paint system breaks at a mean tensile stress of 20 MPa and examination of the area on each side of the site of separation reveals a mean of approximately 30 % of the dolly area associated with cohesive failure of the first coat and 70 % of the dolly area associated with intercoat adhesive failure between the first and second coats, the pull-off test result is expressed as follows:

20 MPa, 30 % B, 70 % B/C

## 10 Precision

No relevant precision data are currently available.

Users of this International Standard should be aware that, because of the subjective assessment of the point at which detachment occurs and the nature of the failure, precision data will only give an indication of the accuracy of the method.

However, the method has been found to be useful in comparing the adhesion of different coatings. It is most useful in providing relative ratings for a series of coated panels exhibiting significant differences in adhesion (see [Clause 1](#)).

## 11 Test report

The test report shall contain at least the following information:

- a) all details necessary to identify the product(s) tested;
- b) a reference to this International Standard, i.e. ISO 4624:2016;
- c) the details of the preparation of the test panels, including
  - 1) the material, the thickness and the surface preparation of the substrate (see [7.1](#)),
  - 2) the method of application of the coating material to the substrate, including the duration and conditions of drying between coats in the case of a multi-coat system (see [7.2](#)),
  - 3) the duration and conditions of drying (or stoving) and ageing (if applicable) of the coating before testing (see [7.3](#)), and
  - 4) the thickness, in micrometres, of the dry coating and the method of measurement used in ISO 2808, and whether it is a single coating or a multi-coat system (see [7.4](#));
- d) the adhesive (and mixing ratios, if applicable) and curing conditions (see also [Clause 5](#));
- e) the length of time and conditions between assembly and testing;
- f) the type of instrument and the diameter of the dolly which was used;
- g) if used, the type of cutting tool employed to cut around the dolly;
- h) the results of the test, reported as indicated in [Clause 9](#);
- i) any deviation from the test method specified;
- j) any unusual features (anomalies) observed during the test;

k) the date of the test.

标格达仪器  
www.biuged.com

标格达仪器  
www.biuged.com

标格达仪器  
www.biuged.com

标格达仪器  
www.biuged.com

标格达仪器  
www.biuged.com

标格达仪器  
www.biuged.com

标格达仪器  
www.biuged.com

标格达仪器  
www.biuged.com

标格达仪器  
www.biuged.com

标格达仪器  
www.biuged.com



## Bibliography

- [1] ISO 2409, *Paints and varnishes — Cross-cut test*

标格达仪器  
www.biuged.com

标格达仪器  
www.biuged.com

标格达仪器  
www.biuged.com

标格达仪器  
www.biuged.com

标格达仪器  
www.biuged.com

标格达仪器  
www.biuged.com

标格达仪器  
www.biuged.com

标格达仪器  
www.biuged.com

标格达仪器  
www.biuged.com

标格达仪器  
www.biuged.com