

INTERNATIONAL
STANDARD

ISO
6504-3

Third edition
2019-11

**Paints and varnishes — Determination
of hiding power —**

**Part 3:
Determination of hiding power of
paints for masonry, concrete and
interior use**

Peintures et vernis — Détermination du pouvoir masquant —

*Partie 3: Détermination du pouvoir masquant pour des peintures
bâtiments, béton et utilisation en intérieur*



Reference number
ISO 6504-3:2019(E)

© ISO 2019



COPYRIGHT PROTECTED DOCUMENT

© ISO 2019

All rights reserved. Unless otherwise specified, or required in the context of its implementation, no part of this publication may be reproduced or utilized otherwise in any form or by any means, electronic or mechanical, including photocopying, or posting on the internet or an intranet, without prior written permission. Permission can be requested from either ISO at the address below or ISO's member body in the country of the requester.

ISO copyright office
CP 401 • Ch. de Blandonnet 8
CH-1214 Vernier, Geneva
Phone: +41 22 749 01 11
Fax: +41 22 749 09 47
Email: copyright@iso.org
Website: www.iso.org

Published in Switzerland

Contents

Page

Foreword	iv
Introduction	v
1 Scope	1
2 Normative references	1
3 Terms and definitions	1
4 Symbols and abbreviated terms	2
5 Principle	4
6 Apparatus	4
7 Sampling	6
8 Procedure and calculation	7
8.1 Preparation of substrate	7
8.1.1 Method A (foil)	7
8.1.2 Method B and Method C (black and white charts)	7
8.2 Preparation of coated foils or black and white charts	7
8.3 Determination of the spreading rate of the test specimen	7
8.3.1 Calculation of the surface mass density	7
8.3.2 Determination of the density	9
8.3.3 Determination of the non-volatile matter	9
8.3.4 Calculation of the theoretical dry- or wet-film thickness (method A, method B and method C)	9
8.3.5 Calculation 1 – Determination of the theoretical spreading rate by calculation from the non-volatile matter content determined in accordance with ISO 3251 and the density of the coating material (see ISO 3233-3) (method A and method B)	10
8.3.6 Calculation 2 – Determination of the theoretical spreading rate calculated with the different coated masses on the two charts (method C), the density of the coating material according to ISO 2811 (all parts) and the coated area	12
8.4 Measurement of tristimulus value Y_{10} and calculation of the hiding power H_{10}	13
8.4.1 General	13
8.4.2 Method A (foil)	13
8.4.3 Method B (black and white charts)	13
8.4.4 Method C (black and white charts)	13
8.5 Graphical method for determination of the hiding power at a given spreading rate (method C)	14
8.5.1 General	14
8.5.2 Determination by graphical method	14
8.5.3 Determination by calculation with a known slope	16
9 Designation of the test result	17
10 Precision	18
11 Test report	18
Annex A (informative) Details on interlaboratory comparison	20
Bibliography	22

Foreword

ISO (the International Organization for Standardization) is a worldwide federation of national standards bodies (ISO member bodies). The work of preparing International Standards is normally carried out through ISO technical committees. Each member body interested in a subject for which a technical committee has been established has the right to be represented on that committee. International organizations, governmental and non-governmental, in liaison with ISO, also take part in the work. ISO collaborates closely with the International Electrotechnical Commission (IEC) on all matters of electrotechnical standardization.

The procedures used to develop this document and those intended for its further maintenance are described in the ISO/IEC Directives, Part 1. In particular, the different approval criteria needed for the different types of ISO documents should be noted. This document was drafted in accordance with the editorial rules of the ISO/IEC Directives, Part 2 (see www.iso.org/directives).

Attention is drawn to the possibility that some of the elements of this document may be the subject of patent rights. ISO shall not be held responsible for identifying any or all such patent rights. Details of any patent rights identified during the development of the document will be in the Introduction and/or on the ISO list of patent declarations received (see www.iso.org/patents).

Any trade name used in this document is information given for the convenience of users and does not constitute an endorsement.

For an explanation of the voluntary nature of standards, the meaning of ISO specific terms and expressions related to conformity assessment, as well as information about ISO's adherence to the World Trade Organization (WTO) principles in the Technical Barriers to Trade (TBT) see www.iso.org/iso/foreword.html.

This document was prepared by Technical Committee ISO/TC 35, *Paints and varnishes*, Subcommittee SC 9, *General test methods for paints and varnishes*.

This third edition cancels and replaces the second edition (ISO 6504-3:2006), which has been technically revised. The main changes compared to the previous edition are as follows:

- the title and Scope have been restricted to paints for masonry and concrete;
- a definition for light-coloured paint has been added;
- a new method (method C), which is suitable for waterborne coating materials only, has been introduced;
- the determination of the mass per unit area of the dry coating and the determination of the practical spreading rate have been deleted (ISO 3233-3 can be used instead);
- the reference to a fixed spreading rate has been deleted from the foreword, scope and test report (it had already been deleted from the procedure in the previous edition);
- the historic precision values for methods A and B have been deleted from the normative part and information on a new interlaboratory comparison on method C has been added in an informative annex, i.e. [Annex A](#);
- the normative references have been updated.

A list of all parts in the ISO 6504 series can be found on the ISO website.

Introduction

Two techniques are available for substrate preparation and measurement when determining the hiding power of paints for masonry and concrete:

- a) application to colourless, transparent foil, the coated foil being subsequently placed in turn over black and white panels;
- b) direct application to black and white charts.

The spreading rate is important for the determination of the hiding power ratio. The spreading rate can be either determined according to ISO 3233-3 or according to another simplified method described in the standards applicable to coating materials for interior walls and ceilings as specified in EN 13300.

Because different operators using the same draw-down device will obtain coatings differing significantly in thickness, an absolute method for the determination of opacity is described in this document. Collaborative trials between groups of experts from a number of countries have shown that reproducible results can be obtained by determination of the hiding power corresponding to a precisely specified spreading rate by interpolation between measurements at two or more measured coating thicknesses nearby and enclosing the specified spreading rate. The interested parties might agree on the specified spreading rate.

The methods are based on the observation that hiding power is an approximately linear function of reciprocal spreading rate, over a restricted coating thickness range which also corresponds to that used for normal application of white or light-coloured paints. It is thus possible to interpolate graphically or by computation, with satisfactory accuracy, between results obtained with coatings of different thicknesses.

Paints and varnishes — Determination of hiding power —

Part 3:

Determination of hiding power of paints for masonry, concrete and interior use

1 Scope

This document specifies methods for determining the hiding power given by paint coats of white or light colours of tristimulus values Y and Y_{10} greater than 25, applied to a black and white chart, or to a colourless transparent foil. In the latter case the tristimulus values Y and Y_{10} are measured over black and white panels. Subsequently, the hiding power is calculated from these tristimulus values.

This document also specifies a simple method for calculating the spreading rate for paints with a volatile matter content with low evaporation speed, e.g. coatings for interior walls and ceilings as specified in EN 13300.

2 Normative references

The following documents are referred to in the text in such a way that some or all of their content constitutes requirements of this document. For dated references, only the edition cited applies. For undated references, the latest edition of the referenced document (including any amendments) applies.

ISO 1513, *Paints and varnishes — Examination and preparation of test samples*

ISO 2811 (all parts), *Paints and varnishes — Determination of density*

ISO 3251, *Paints, varnishes and plastics — Determination of non-volatile-matter content*

ISO 3233-3:2015, *Paints and varnishes — Determination of the percentage volume of non-volatile matter — Part 3: Determination by calculation from the non-volatile-matter content determined in accordance with ISO 3251, the density of the coating material and the density of the solvent in the coating material*

ISO 15528, *Paints, varnishes and raw materials for paints and varnishes — Sampling*

EN 13300, *Paints and varnishes — Water-borne coating materials and coating systems for interior walls and ceilings — Classification*

3 Terms and definitions

For the purposes of this document, the following terms and definitions apply.

ISO and IEC maintain terminological databases for use in standardization at the following addresses:

— ISO Online browsing platform: available at <https://www.iso.org/obp>

— IEC Electropedia: available at <http://www.electropedia.org/>

3.1

light-coloured paint

coating with tristimulus values Y and Y_{10} greater than 25, measured with a spectrophotometer on a black and white substrate

[SOURCE: ISO 6504-1:2019, 3.1]

3.2

spreading rate

surface area that can be covered by a given quantity of coating material to give a dried film of requisite thickness

Note 1 to entry: It is expressed in m^2/l or m^2/kg .

Note 2 to entry: See also application rate, practical spreading rate and theoretical spreading rate.

[SOURCE: ISO 4618:2014, 2.238]

3.3

practical spreading rate

spreading rate (3.2) which is obtained in practice on the particular substrate being coated

[SOURCE: ISO 4618:2014, 2.203]

3.4

theoretical spreading rate

spreading rate (3.2) calculated solely from the volume of non-volatile matter

[SOURCE: ISO 4618:2014, 2.256]

3.5

hiding power

ability of a coating to obliterate the colour or colour differences of the substrate

Note 1 to entry: The use of the German expressions "Deckkraft" and "Deckfähigkeit" should be avoided.

Note 2 to entry: The term "coverage" is ambiguous because it is used in some instances to refer to hiding power and in others to mean spreading rate. The more precise terms hiding power and spreading rate should always be used.

[SOURCE: ISO 4618:2014, 2.138]

3.6

tristimulus values (of a colour stimulus)

amounts of the three reference stimuli, in a given trichromatic system, required to match the colour of the stimulus considered

Note 1 to entry: In the CIE standard colorimetric systems, the tristimulus values are represented by the symbols X, Y, Z and X_{10}, Y_{10}, Z_{10} .

[SOURCE: ISO 11664-2:2007, 3.14]

4 Symbols and abbreviated terms

A_c	dry area of the coated charts of the area cut out in each case
A_f	dry area of the coated foils of the part cut out in each case
A_n	dry area of the part of the foil or charts cut out in each case
A_{wc}	wet area of the coated charts
H_{10}	hiding power
H_{10c}	hiding power of the coated chart
H_{10f}	hiding power of the coated foil
H_{10cl}	hiding power for the chart with the low coating thickness

H_{10ch}	hiding power for the chart with the high coating thickness
m	slope of the straight line
\bar{m}_c	mean value of the mass of the coated charts
\bar{m}_f	mean value of the mass of the coated foils
\bar{m}_{uf}	mean value of the mass of the uncoated foils
m_{uc}	mass of the uncoated chart
m_{wc}	mass of the wet coated chart
m_{wch}	mass of the high wet-film thickness on the chart
m_{wcl}	mass of the low wet-film thickness on the chart
n	interception of the Y-axis at the point zero of the X-axis, $P(0,n)$
NV	non-volatile matter content of the coating material
NV_w	the non-volatile-matter content of the wet coating
ρ_{Ac}	surface mass density of the dry coating on the charts
ρ_{Af}	surface mass density of the dry coating on the foils
ρ_{An}	surface mass density of the dry coating on the foils or charts or wet coating on the charts
ρ_{Awch}	surface mass density of the coat with the high wet-film thickness on the chart
ρ_{Awcl}	surface mass density of the coat with the low wet-film thickness on the chart
ρ_1	density of the coating material
$stAm$	theoretical spreading rate
S_{tAVg}	given theoretical spreading rate
S_{tAVh}	theoretical spreading rate for the chart with the high coating thickness
S_{tAVl}	theoretical spreading rate for the chart with the low coating thickness
S_{tcm}	theoretical spreading rate of the dry coating on the charts relative to the mass
S_{tcV}	theoretical spreading rate of the dry coating on the charts relative to the volume
S_{tfm}	theoretical spreading rate of the dry coating on the foils relative to the mass
S_{tfV}	theoretical spreading rate of the dry coating on the foils relative to the volume
t_{td}	theoretical dry-film thickness
t_{tc}	theoretical dry film thickness of the coating on charts
t_{tf}	theoretical dry film thickness of the coating on foils
t_{tn}	theoretical dry film thickness of the coating on foils or charts
t_w	theoretical wet-film thickness

t_{wl}	theoretical low wet-film thickness
t_{wh}	theoretical high wet-film thickness
\bar{Y}_{10b}	mean value of the tristimulus value measured over the black areas
\bar{Y}_{10bh}	mean value of the tristimulus value measured over the black areas of the high coating thickness
\bar{Y}_{10bl}	mean value of the tristimulus value measured over the black areas of the low coating thickness
\bar{Y}_{10w}	mean value of the tristimulus value measured over the white areas
\bar{Y}_{10wh}	mean value of the tristimulus value measured over the white areas of the high coating thickness
\bar{Y}_{10wl}	mean value of the tristimulus value measured over the white areas of the low coating thickness
X, Y, Z	tristimulus values of test stimulus calculated using the colour-matching functions of the CIE 1931 standard colorimetric system (also known as the CIE 2° standard colorimetric system) [See ISO 11664-4:2007, Clause 3]
X_{10}, Y_{10}, Z_{10}	tristimulus values of a specific white colour stimulus calculated using the colour-matching functions of the CIE 1964 standard colorimetric system

Where tristimulus values are calculated using the colour-matching functions of the CIE 1964 standard colorimetric system (also known as the CIE 10° standard colorimetric system), a subscript 10 shall be added to all the above symbols (See ISO 11664-4:2007, Clause 3).

5 Principle

For method A, coated transparent foils are fixed over a black and white panel. The spreading rate is calculated from the measurements of the surface mass density and the theoretical dry-film thickness. The tristimulus values Y_{10} of the coated foils are measured over the black and white areas. The hiding power is calculated as a quotient of these values as a percentage for each coated foil.

For method B, black and white charts are coated and dried (or stoved). The spreading rate is calculated from the measurements of the surface mass density and the theoretical dry-film thickness. The tristimulus values Y_{10} of each coated chart are measured over the black and white areas. The hiding power is calculated as a quotient of these values as a percentage for each coated chart.

For method C, black and white charts are coated. The spreading rate is calculated from the measurements of the coated area (whole charts), of the density of the coating material and the mass difference of the uncoated and coated charts. Then the coating is dried. The tristimulus values Y_{10} of each coated chart are measured over the black and white areas. The hiding power is calculated as a quotient of these values as a percentage for each coated chart.

6 Apparatus

Ordinary laboratory apparatus and glassware, together with the following:

- 6.1 **Substrate**, conforming to the requirements of [8.1.1](#) or [8.1.2](#).
- 6.2 **Three colourless transparent foils (method A)**, untreated.

6.3 Three black and white charts (method B) and two or four (see 6.4) black and white charts (method C), all the same size and measuring at least 100 mm × 200 mm, printed and varnished to give adjacent black and white areas readily wetted by, but impervious to, solvent- or water-based paints.

The black and white areas shall have dimensions bigger than the measurement area of the spectrophotometer. The tristimulus value Y_{10} of the white areas of the charts shall be 80 ± 2 when measured using a spectrophotometer or spectrophotometer complying with 6.5, and that of the black area shall not be greater than 5, unless otherwise agreed.

To avoid errors due to variation from one batch of charts to another, the charts used for the test shall come from the same batch.

If the chart is a metal plate, both the black and the white areas shall be coated on the back and edges with black paint or adhesive tape to exclude light reflected from the back.

Ensure that only black and white charts without optical brighteners are used.

6.4 Film applicators, selected to give a range of films of uniform wet film thickness.

For method C, the film applicators need to be of slightly different sizes, i.e. max. 50 µm difference in size in order to give suitable coating thicknesses, allowing the assumption of linearity in spreading rate for the calculation. The gap of the applicators depends on the type of coating material and its viscosity.

The application of uniform films is facilitated by the use of automatic applicators, which are recommended.

If a coating material with an unknown relation between film applicator gap height and spreading rate is tested, use up to four different film applicators with different gap heights to cover the given spreading rate.

6.5 Spectrophotometer, to measure the tristimulus value Y_{10} .

It is recognized that the relative geometrical arrangement of the illumination beam and the light detector can affect the measurement of Y_{10} , but it is considered that variations arising from this factor in commercial spectrophotometers should be considerably less than the reproducibility limit stated in [Clause 9](#). When using the sphere geometry, the surface reflection has to be considered by either:

- reducing the tristimulus value Y_{10} by the corresponding surface reflection correction value in [Table 1](#) (for an example, see [Figure 1](#)), or
- by measuring the tristimulus value Y_{10} with correction for surface reflection with a sphere 8° (diffuse) geometry (for an example, see [Figure 2](#)).

Table 1 — Surface reflection correction with respect to the gloss property of coating

Designation	Angle of incidence	Reflectance	Surface reflection correction
Gloss	60°	≥70	4
Mid sheen	60°	<70	2
	85°	≥10	
Matt	85°	<10	0
Dead-matt	85°	<5	0

NOTE For columns 1 to 3 see EN 13300, except that the reflectance limit from gloss to mid sheen is corrected from 60 to 70.

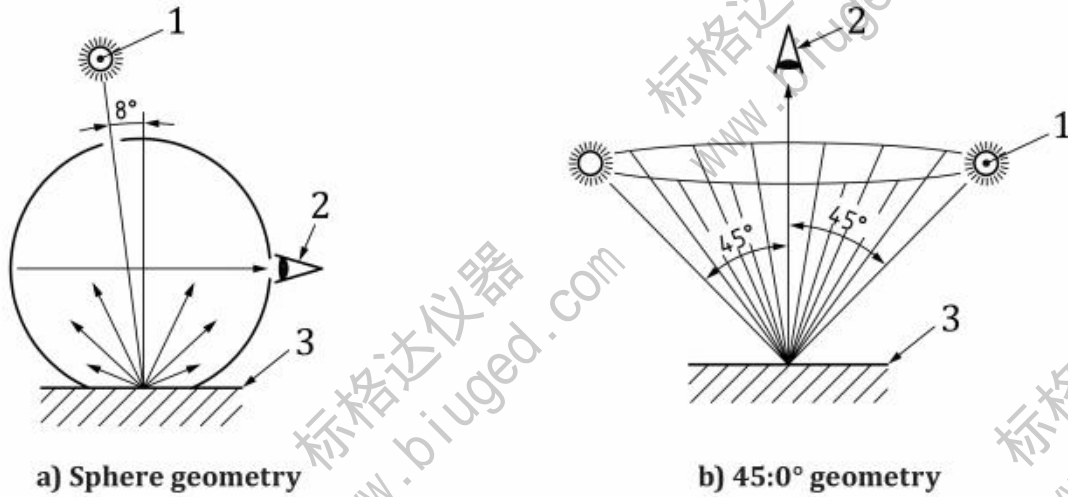

Key

- 1 light source, daylight D65
- 2 photo detector
- 3 test area

Figure 1 — Example for a spectrophotometer; sphere and 45:0° geometry

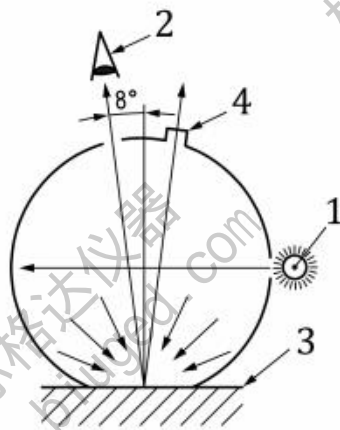

Key

- 1 light source, daylight D65
- 2 photo detector
- 3 test area
- 4 gloss trap

Figure 2 — Example for a spectrophotometer; sphere with gloss trap

6.6 Analytical balance, capable of weighing to the nearest 0,1 mg.

7 Sampling

Take a representative sample of the product to be tested, as described in ISO 15528.

Examine and prepare the sample for testing as described in ISO 1513.

8 Procedure and calculation

8.1 Preparation of substrate

8.1.1 Method A (foil)

Retain, for use in 8.4, an uncoated sample of foil from an area adjacent to the surface to be coated.

Fix it at one end and lay it over a flat rubber block. After application prepare the second foil in the same manner.

8.1.2 Method B and Method C (black and white charts)

Store the black and white substrate charts under the test conditions [(23 ± 2) °C and a relative humidity of (50 ± 5) %] for at least 16 h before coating; handle them at all times by the edges to avoid finger prints on the areas to be coated.

Fix each chart at one end, by clips or adhesive tape, to a flat panel, using a vacuum suction plate or fixing it at one end, and lay it over a flat rubber block.

Prepare each of the three charts (for method B), or of the two or four (see 6.4) charts (for method C) for coating in the same manner.

8.2 Preparation of coated foils or black and white charts

Immediately before application, mix the paint thoroughly by vigorous stirring to break down any thixotropic structure, taking care not to incorporate air bubbles.

Apply the paint, depending on the coating thickness required, in a line across one end of the chart or foil and spread it immediately by drawing down a suitable applicator at a steady speed to give a uniform layer.

For method A and method B, fix the coated foils or charts in a horizontal position until dry, for example by taping the edges to a flat substrate.

The drying time (and/or stoving conditions) depends on the type of paint material under test and should be agreed by the interested parties.

For method C, determine the surface mass density and the theoretical wet-film thickness of the wet coatings immediately after application. Dry the coated charts at (23 ± 2) °C and a relative humidity of (50 ± 5) % for at least 16 h before the measurements of the tristimulus values Y_{10} are made.

8.3 Determination of the spreading rate of the test specimen

8.3.1 Calculation of the surface mass density

For all methods A, B, and C, the calculation formula of the surface mass density is nearly the same.

8.3.1.1 Surface mass density method A with foils

Remove the coated foil from the glass panel, wipe the foil to remove any traces of white spirit and allow to dry.

Cut an equal area with dimensions at least 60 mm × 60 mm, for example by means of a precision die stamp.

Cut two pieces from the uncoated foil and weigh to the nearest 1 mg (m_{uf1} , m_{uf2}) and cut from the centre of each coated foil one piece and weigh to the nearest 1 mg (m_{f1} , m_{f2}).

Calculate of every two results the mean values \bar{m}_{uf} and \bar{m}_f .

Calculate the surface mass density ρ_{Af} of dry coating on the foils, in grams per square millimetre, using [Formula \(1\)](#):

$$\rho_{Af} = \frac{\bar{m}_f - \bar{m}_{uf}}{A_f} \quad (1)$$

where

\bar{m}_f is the mean value of the mass, in grams, of the coated foils;

\bar{m}_{uf} is the mean value of the mass, in grams, of the uncoated foils;

A_f is the dry area of the coated foils, in square millimetres, of the area cut out in each case.

8.3.1.2 Surface mass density method B with charts with dried/stoved coat

Cut equal areas with dimensions at least 60 mm × 60 mm from the uncoated and coated charts, for example by means of a precision die stamp.

Cut one piece from the centre of the uncoated chart and weigh to the nearest 1 mg (m_{uc}).

Cut one piece from the centre of each of the two coated charts and weigh to the nearest 1 mg (m_{c1} , m_{c2}).

Calculate the mean value of the coated charts \bar{m}_c .

Calculate the surface mass density, ρ_{Ac} of dry coating on the charts, in grams per square millimetre, using [Formula \(2\)](#):

$$\rho_{Ac} = \frac{\bar{m}_c - m_{uc}}{A_c} \quad (2)$$

where

\bar{m}_c is the mean value of the mass, in grams, of the coated charts;

m_{uc} is the mass, in grams, of the uncoated chart;

A_c is the dry area of the coated charts, in square millimetres, of the area cut out in each case.

8.3.1.3 Surface mass density method C with charts with two different wet-film thicknesses

Weigh each of the uncoated charts to the nearest 1 mg (m_{uc}).

Coat one of the charts with the applicator for the low coating thickness and the other chart with the applicator for the high coating thickness.

Immediately after application, weigh each chart again to the nearest 1 mg (m_{wc1} , m_{wc2}).

Calculate the surface mass density, ρ_{Awcl} , of wet coat with the low coating thickness and the surface mass density, ρ_{Awch} , of wet coat with the high coating thickness, in grams per square millimetre, using [Formulae \(3\)](#) and [\(4\)](#):

$$\rho_{Awcl} = \frac{m_{wcl} - m_{uc}}{A_{wc}} \quad (3)$$

and

$$\rho_{Awch} = \frac{m_{wch} - m_{uc}}{A_{wc}} \quad (4)$$

where

m_{wcl} is the mass, in grams, of the low wet-film thickness on the chart;

m_{wch} is the mass, in grams, of the high wet-film thickness on the chart;

m_{uc} is the mass, in grams, of the uncoated chart;

A_{wc} wet area, in square millimetres, of the coated charts.

8.3.2 Determination of the density

Determine the density for both spreading rate calculations 1 and 2 of the coating material (ρ_1) to the nearest $0,001 \text{ g/cm}^3$ in accordance with one of the methods specified in ISO 2811 (all parts).

Depending on the coating material under test the sample shall be deaerated prior to the determination in order to produce robust results for the density.

NOTE For water-based coating materials, methods such as deaeration with the help of a centrifuge at $2\,000 \text{ min}^{-1}$ for 30 s have been found suitable.

8.3.3 Determination of the non-volatile matter

For spreading rate calculation 4, determine the non-volatile matter content (NV) as described in ISO 3251.

8.3.4 Calculation of the theoretical dry- or wet-film thickness (method A, method B and method C)

Calculate the theoretical dry-film thickness, t_{td} , (methods A and B), in millimetres, following [Formula \(5\)](#):

$$t_{td} = \frac{\rho_{An}}{\rho_1 \cdot NV} \cdot 10^5 \quad (5)$$

For water thinnable coating materials, the evaporation can be neglected; NV and the surface mass density do not change significantly during testing. Considering $\rho_{An} = \rho_{Awc} \cdot NV$, calculate the theoretical low and high wet-film thicknesses, t_{twl} and t_{twh} , (method C), in millimetres, following [Formula \(6\)](#):

$$t_{twl} = \frac{\rho_{Awcl}}{\rho_1} \cdot 10^3 \text{ and } t_{twh} = \frac{\rho_{Awch}}{\rho_1} \cdot 10^3 \quad (6)$$

where

- ρ_{An} is the surface mass density, in grams per square millimetre, of the dry coating on the foils (A_f) or charts (A_c), or wet coating on the charts (A_{wc});
- ρ_{Awcl} is the surface mass density, in grams per square millimetre, of the coat with the low wet-film thickness on the chart;
- ρ_{Awch} is the surface mass density, in grams per square millimetre, of the coat with the high wet-film thickness on the chart;
- ρ_1 is the density, in grams per cubic centimetre, of the coating material;
- NV is the non-volatile matter content, as a percentage mass fraction, of the coating material (ISO 3251);
- 10^5 is a factor relating to the conversion of various units.

8.3.5 Calculation 1 – Determination of the theoretical spreading rate by calculation from the non-volatile matter content determined in accordance with ISO 3251 and the density of the coating material (see ISO 3233-3) (method A and method B)

The spreading rate of a coating material indicates the area which can be covered by a given quantity of coating material.

The theoretical spreading rate is a value which is calculated solely from the non-volatile matter by volume. The practical spreading rate, on the other hand, is a value which is obtained when coating an individual work specimen in practice.

Based on the definition of the spreading rate (see ISO 3233-3:2015, Annex B) the theoretical spreading rate, s_{tnV} in square metres per litre, is the quotient of the surface area coated and the volume required for [Formulae \(7\) to \(9\)](#) or the mass in [Formulae \(10\) and \(11\)](#):

$$s_{tnV} = \frac{1}{t_{tn}} = \frac{\rho_1 \times NV}{\rho_{An}} \times 10^{-5} \quad (7)$$

Therefore, for coated foils follow:

$$s_{tfV} = \frac{1}{t_{tf}} = \frac{\rho_1 \times NV}{\rho_{Af}} \times 10^{-5} \quad (8)$$

and for coated charts:

$$s_{tcV} = \frac{1}{t_{tc}} = \frac{\rho_1 \times NV}{\rho_{Ac}} \times 10^{-5} \quad (9)$$

and using the deviation for the spreading rate in ISO 3233-3 together with [Formula \(1\)](#) for mass per area of the dry coating on foils, in square metres per kilogram (see method A):

$$s_{tfm} = \frac{A_f \times NV}{\bar{m}_f - \bar{m}_{uf}} \times 10^{-5} \quad (10)$$

or when using [Formula \(2\)](#) for mass per area of the dry coating on charts (see method B):

$$s_{tcm} = \frac{A_c \times NV}{\bar{m}_c - \bar{m}_{uc}} \times 10^{-5} \quad (11)$$

where

- s_{tfV} is the theoretical spreading rate, in square metres per litre, of the dry coating on foils relative to the volume
- s_{tcV} is the theoretical spreading rate, in square metres per litre, of the dry coating on charts relative to the volume;
- s_{tfm} is the theoretical spreading rate, in square metres per kilogram, of the dry coating on foils relative to the mass;
- s_{tcm} is the theoretical spreading rate, in square metres per kilogram, of the dry coating on charts relative to the mass;
- A_c is the dry area, in square millimetres, of the chart cut out in each case (method B);
- A_f is the dry area, in square millimetres, of the foil cut out in each case (method A);
- A_n is the dry area, in square millimetres, of the part of the foil or charts cut out in each case (method A or B);
- t_{tc} is the theoretical dry film thickness, in millimetres, of the coating on charts (t_{tc});
- t_{tf} is the theoretical dry film thickness, in millimetres, of the coating on foils (t_{tf});
- t_{tn} is the theoretical dry film thickness, in millimetres, of the coating on foils (t_{tf}) or charts (t_{tc});
- ρ_1 is the density, in grams per cubic centimetre, of the coating material;
- ρ_{An} is the surface mass density, in grams per square millimetre, of the dry coating on the foils (A_f) or charts (A_c), or wet coating on the charts (A_{wc});
- ρ_{Ac} is the surface mass density, in grams per square millimetre, of the dry coating on charts (A_c);
- ρ_{Af} is the surface mass density, in grams per square millimetre, of the dry coating on foils (A_f);
- NV is the non-volatile-matter content, as a percentage mass fraction, of the coating material;
- \bar{m}_f is the mean value of the mass, in grams, of the coated foils (method A);
- \bar{m}_c is the mean value of the mass, in grams, of the coated charts (method B);
- \bar{m}_{uf} is the mean value of the mass, in grams, of the uncoated foils (method A);
- m_{uc} is the mass, in grams, of the uncoated chart (method B);
- 10^{-5} is a factor relating to the conversion of various units.

NOTE For information on the derivation of the dry-film thickness and of the theoretical spreading rate, see ISO 3233-3:2015, Annex A and Annex B, respectively.

8.3.6 Calculation 2 – Determination of the theoretical spreading rate calculated with the different coated masses on the two charts (method C), the density of the coating material according to ISO 2811 (all parts) and the coated area

Based on the definition of the spreading rate, the theoretical spreading rate, s_{tAm} , in square metres per kilogram, is the quotient of the surface area coated and the mass required for [Formula \(12\)](#) or for the volume the theoretical spreading rate, s_{tAV} , in square metres per litre shown in [Formulae \(14\)](#) and [\(15\)](#):

$$s_{tAm} = \frac{A_{wc} \times NV_w}{m_{wc} - m_{uc}} \times 10^{-5} \quad (12)$$

The weighings are carried out in short time intervals, so it is assumed that evaporation of volatile matter and the effect on the mass can be neglected. And NV_w is to be considered as 100 %, thereof follows [Formula \(13\)](#):

$$s_{tAm} = \frac{A_{wc}}{m_{wc} - m_{uc}} \times 10^{-3} \quad (13)$$

NOTE NV_w is in this case not equivalent to the determination in accordance with ISO 3251.

In case that the correlation between film applicator gap height and spreading rate is not known and four charts have been used (see [6.4](#)), calculate all spreading rates following [Formula \(13\)](#). Subsequently, the two determined spreading rates encompassing the desired given spreading rate are used for the further calculations as s_{tAVl} (next spreading rate lower than the given spreading rate) and s_{tAVh} (next spreading rate higher than the given spreading rate) in [Formulae \(14\)](#) and [\(15\)](#).

Considering that the coating material has a low loss of volatile matter due to evaporation and considering [Formula \(6\)](#), the theoretical spreading rate can be directly calculated from the mass of wet coating on charts, following [Formulae \(14\)](#) and [\(15\)](#):

$$s_{tAVl} = \frac{1}{t_{wl}} = \frac{A_{wc} \times \rho_1}{m_{uc} - m_{wcl}} \times 10^{-3} \quad (14)$$

and

$$s_{tAVh} = \frac{1}{t_{wh}} = \frac{A_{wc} \times \rho_1}{m_{uc} - m_{wch}} \times 10^{-3} \quad (15)$$

where

s_{tAVl} is the theoretical spreading rate, in square metres per litre, for the chart with the low coating thickness;

s_{tAVh} is the theoretical spreading rate, in square metres per litre, for the chart with the high coating thickness;

t_{wl} is the theoretical low wet-film thickness, in millimetres;

t_{wh} is the theoretical high wet-film thickness, in millimetres;

A_{wc} is the wet area, in square metres, of the coated charts;

ρ_1 is the density, in grams per cubic centimetre, of the coating material;

m_{uc} is the mass, in grams, of the uncoated chart;

m_{wc} is the mass, in grams, of the wet coated chart;

m_{wcl} is the mass, in grams, of the low wet-film thickness on the chart;

- m_{wch} is the mass, in grams, of the high wet-film thickness on the chart;
- NV_{w} is the non-volatile-matter content, as a percentage mass fraction, of the wet coating;
- 10^{-3} is a factor relating to the conversion of various units (cubic centimetres into litres).

8.4 Measurement of tristimulus value Y_{10} and calculation of the hiding power H_{10}

8.4.1 General

If not otherwise agreed, measure with the spectrophotometer the tristimulus value Y_{10} in accordance with CIE 1964 (see definition 3.5).

The hiding power, H_{10} , as a percentage, is defined as the quotient of the tristimulus value Y_{10b} measured over the black area and the tristimulus value Y_{10w} measured over the white area. It is shown in [Formula \(16\)](#):

$$H_{10} = \frac{Y_{10b}}{Y_{10w}} \cdot 10^2 \quad (16)$$

8.4.2 Method A (foil)

Fix each coated foil over a black and white panel, introducing a few drops of white spirit between the underside of the foil and the panel to ensure optical contact. Measure the tristimulus value Y_{10} of each coated foil at a minimum of four positions over the black (Y_{10b}) and white (Y_{10w}) areas, and calculate the mean tristimulus values \bar{Y}_{10b} and \bar{Y}_{10w} respectively. Then calculate the hiding power H_{10f} as a percentage, for each coated foil:

$$H_{10f} = \frac{\bar{Y}_{10b}}{\bar{Y}_{10w}} \cdot 10^2 \quad (17)$$

where

\bar{Y}_{10b} is the mean value of the tristimulus value measured over the black areas;

\bar{Y}_{10w} is the mean value of the tristimulus value measured over the white areas.

8.4.3 Method B (black and white charts)

Measure the tristimulus value Y_{10} of each coated chart at a minimum of four positions over both the black and white areas of each chart and calculate the mean tristimulus values \bar{Y}_{10b} and \bar{Y}_{10w} respectively. Then calculate the hiding power H_{10c} as a percentage, for each coated chart:

$$H_{10c} = \frac{\bar{Y}_{10b}}{\bar{Y}_{10w}} \cdot 10^2 \quad (18)$$

where

\bar{Y}_{10b} is the mean value of the tristimulus value measured over the black areas;

\bar{Y}_{10w} is the mean value of the tristimulus value measured over the white areas.

8.4.4 Method C (black and white charts)

After drying the two or four coated charts at $(23 \pm 2)^\circ\text{C}$ and a relative humidity of $(50 \pm 5)\%$ for at least 16 h, measurements of the tristimulus values Y_{10} can be done.

Measure the tristimulus values of each coated chart at a minimum of three positions over both the black and white areas of each chart and calculate the mean tristimulus values \bar{Y}_{10b} and \bar{Y}_{10w} for the low and high coatings respectively. Then calculate the hiding power H_{10cl} and H_{10ch} for each coated chart, as a percentage:

$$H_{10cl} = \frac{\bar{Y}_{10bl}}{\bar{Y}_{10wl}} \cdot 10^2 \quad (19)$$

and

$$H_{10ch} = \frac{\bar{Y}_{10bh}}{\bar{Y}_{10wh}} \cdot 10^2 \quad (20)$$

where

\bar{Y}_{10bl} is the mean value of the tristimulus value measured over the black areas of the low coating thickness;

\bar{Y}_{10wl} is the mean value of the tristimulus value measured over the white areas of the low coating thickness;

\bar{Y}_{10bh} is the mean value of the tristimulus value measured over the black areas of the high coating thickness;

\bar{Y}_{10wh} is the mean value of the tristimulus value measured over the white areas of the high coating thickness.

8.5 Graphical method for determination of the hiding power at a given spreading rate (method C)

8.5.1 General

Assuming that the hiding power and the spreading rate have a linear behaviour, the hiding power at a given spreading rate could also be determined by a graphical method by linear interpolation or directly by calculation with the known value for the slope.

8.5.2 Determination by graphical method

Insert the calculated results of both the spreading rates (low and high coating thicknesses) from [Formulae \(14\)](#) and [\(15\)](#) together with both the calculated hiding powers from [Formulae \(19\)](#) and [\(20\)](#) in a diagram, where the X-axis is the spreading rate, in square metres per litre, and the hiding power is the Y-axis, as a percentage.

An example for two charts is shown in [Figure 3](#). At a given spreading rate, take at the Y-axis the corresponding value for the hiding power.

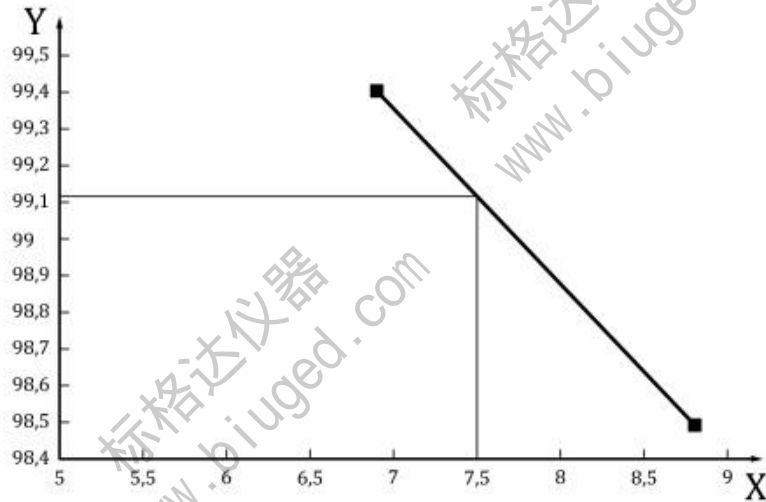
**Key**

X-axis spreading rate, in square metres per litre

Y-axis hiding power, as a percentage

Figure 3 — Example for calculation of a hiding power at a given spreading rate of 7,5 m²/l from two charts with low and high coating thickness

An example for four charts (see 6.4) is shown in Figure 4. At a given spreading rate, take the corresponding value for the hiding power at the Y-axis. Identify the next lower and the next higher spreading rate with respect to the given spreading rate. Use these spreading rates for interpolation.

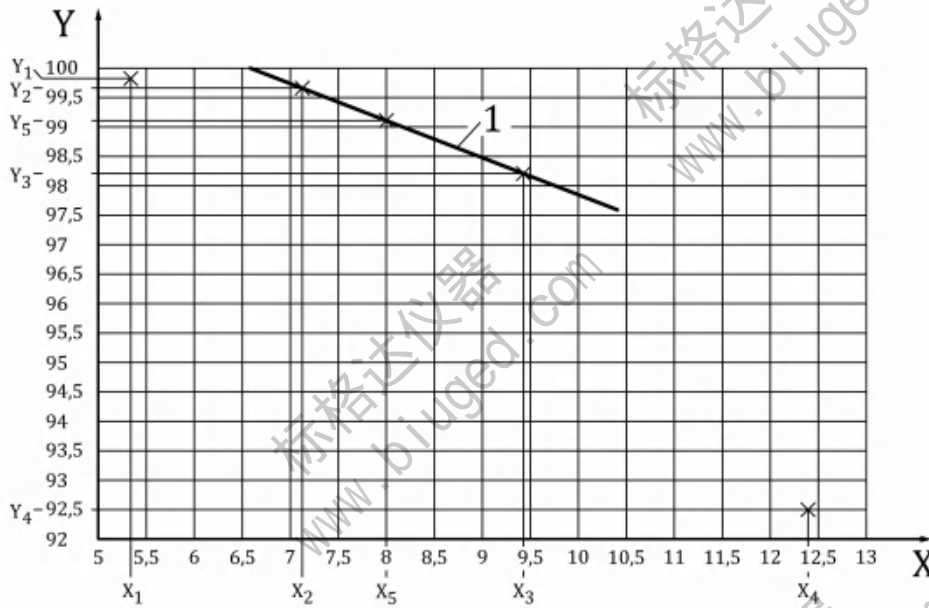

Key

- X-axis spreading rate, in square metres per litre
- Y-axis hiding power, as a percentage
- X_1 spreading rate of the first chart; in this example $X_1 = 5,3 \text{ m}^2/\text{l}$
- X_2 spreading rate of the second chart, identical to s_{tAVh} ; in this example $X_2 = 7,1 \text{ m}^2/\text{l}$
- X_3 spreading rate of the third chart, identical to s_{tAVl} ; in this example $X_3 = 9,4 \text{ m}^2/\text{l}$
- X_4 spreading rate of the fourth chart; in this example $X_4 = 12,4 \text{ m}^2/\text{l}$
- X_5 given theoretical spreading rate, s_{tAVg} ; in this example $X_5 = 8,0 \text{ m}^2/\text{l}$
- Y_1 hiding power of the first chart; in this example $Y_1 = 99,92 \%$
- Y_2 hiding power of the second chart, identical to H_{10ch} ; in this example $Y_2 = 99,75 \%$
- Y_3 hiding power of the third chart, identical to H_{10cl} ; in this example $Y_3 = 98,23 \%$
- Y_4 hiding power of the fourth chart; in this example $Y_4 = 92,64 \%$
- Y_5 hiding power of the given spreading rate, H_{10g} ; in this example $Y_5 = 99,2 \%$
- 1 interpolation line

Figure 4 — Example for calculation of a hiding power at a given spreading rate of $8,0 \text{ m}^2/\text{l}$ from four charts

8.5.3 Determination by calculation with a known slope

Assuming a linear behaviour (see also 6.4) of the spreading rate and the hiding power, and using the linear function for calculating the slope with the assumptions m and n are constant and $m \neq 0$, Formula (21) is valid:

$$f(x) = y = mx + n \tag{21}$$

where

- m is the slope of the straight line;
- n is the interception of the Y-axis at the point zero of the X-axis, $P(0,n)$.

Considering the spreading rates and hiding powers with low and high coating thicknesses, calculate the slope:

$$m = \frac{(y_2 - y_1)}{(x_2 - x_1)} = \frac{(H_{10ch} - H_{10cl})}{(-s_{tAVh} - s_{tAVl})} \quad (22)$$

and also the interception of the Y-axis at P(0,n) with the results for the low or high coating thickness as shown in [Formulae \(14\), \(15\), \(19\) and \(20\)](#).

NOTE The slope m is negative (see [Figure 3](#)).

The slope has the same value on each point of the straight line; therefore it follows:

$$n = H_{10cl} - m \cdot s_{tAVl} \quad (23)$$

or

$$n = H_{10ch} - m \cdot s_{tAVh} \quad (24)$$

Considering [Formula \(21\)](#) calculate the hiding power H_{10cg} , as a percentage, with a given spreading rate s_{tAVg} , the slope of the straight line m and the value for the interception of the Y-axis at the point zero of the X-axis P(0,n) n :

$$H_{10cg} = m \cdot s_{tAVg} + n \quad (25)$$

where

m is the slope of the straight line;

n is the interception of the Y-axis at the point zero of the X-axis P(0,n);

s_{tAVl} is the theoretical spreading rate, in square metres per litre, for the chart with the low coating thickness;

s_{tAVh} is the theoretical spreading rate, in square metres per litre, for the chart with the high coating thickness;

s_{tAVg} is the given theoretical spreading rate, in square metres per litre;

H_{10cl} is the hiding power, as a percentage, for the chart with the low coating thickness;

H_{10ch} is the hiding power, as a percentage, for the chart with the high coating thickness.

9 Designation of the test result

A designation code which may be used to indicate the test result is given below. It shall comprise a reference to this document, a reference to the method used for the determination of the surface mass density, a reference to the method used for calculation of the theoretical spreading rate and the Y_{10} value for the hiding power. For example:

ISO 6504-3:YYYY — A — 1 — H_{10f}

Number of this document — Method used — Calculation method — Hiding power

Key for the method and calculation used:

- A Surface mass density method A with foils
- B Surface mass density method B with charts with dried/stoved coat
- C Surface mass density method C with charts with wet coat

- 1 Calculation 1 – Determination of the theoretical spreading rate by calculation from the non-volatile matter content determined in accordance with ISO 3251 and the density of the coating material according to ISO 2811 (all parts) (see ISO 3233-3).
- 2 Calculation 2 – Determination of the theoretical spreading rate calculated with the coated mass on the charts (method C), the density of the coating material according to ISO 2811 (all parts) and the coated area

H_{10} Value for hiding power, i.e.

H_{10f} hiding power for foils

H_{10c} hiding power for charts (method B)

H_{10cg} hiding power for charts (method C) at a given spreading rate

EXAMPLE Possible combinations are: A – 1 – H_{10f} , B – 1 – H_{10c} , or C – 2 – H_{10cg} .

10 Precision

No precision data are currently available.

Details on a preliminary round robin test are given in [Annex A](#) for information.

11 Test report

The test report shall contain at least the following information:

- a) all information necessary for identification of the sample tested;
- b) a reference to this document (ISO 6504-3:2019);
- c) the method used (A, B or C) and:
 - 1) if method A was used, the values Y_{10b} or Y_{10w} for the foil over black and white glass; or
 - 2) if method B was used, the corresponding values for the charts; or
 - 3) if method C was used, the calculated value for the hiding power at a given spreading rate;
- d) if method A was used, the thickness of the foils;
- e) the drying time and/or stoving conditions;
- f) the values of the coating density and, if the spreading rate calculation 1 was used (see [8.3.5](#)), the non-volatile matter;
- g) the results of the test expressed as the hiding power as specified in [8.4](#);
- h) any deviations from the procedure specified;
- i) any unusual features (anomalies) observed during the test;

j) the date of the test.

Annex A (informative)

Details on interlaboratory comparison

A.1 General notes on an interlaboratory comparison of method C

An interlaboratory comparison (ILC) has been carried out for the determination of the precision of method C by determination of the density of the liquid paint, measurement of the hiding power of the dry coating and by calculation of the theoretical spreading rate using [Formulae \(3\) and \(4\)](#) (see [8.3.1.3](#)).

Five laboratories participated in the ILC with different measurement instruments for the density and for the hiding power.

A.2 Sample

The interlaboratory comparison was carried out with a white matt water-based coating material for architectural coatings.

A.3 Determination of the density

The density of the water-based coating material was measured in accordance with ISO 2811-1 pycnometer method (see [8.3.2](#)).

Each of the five laboratories has carried out a six-fold determination with its own pycnometer.

The mean value of the density for the calculation of the wet-film thickness (see [8.3.4](#)) was calculated centrally.

A.4 Preparation of the black and white charts

The black and white charts were prepared in accordance with [8.2](#), method C.

Every laboratory has used its own black and white chart type. All chart types were differently.

Each laboratory has used its own film applicators with different height for preparing the wet film. The difference of the height of the two film applicators was not larger than 50 µm.

A.5 Determination of the theoretical spreading rate

The theoretical spreading rate was calculated in accordance with [Formulae \(14\) and \(15\)](#) (see [8.3.6](#), calculation 2).

A.6 Determination of the hiding power

Each laboratory used its own spectrophotometer in order to measure the tristimulus value of each chart before and after coating in accordance with CIE 1964 (see [8.4.1](#)).

The hiding power for each chart and the mean value over all charts was calculated centrally.

A.7 Evaluation without error propagation

The hiding power results were evaluated in accordance with ISO 5725-2 and ISO/TR 22971.

The error propagation which has potentially a significant influence on the test result has not been considered in the calculated precision yet.

The calculated precision for the matt water-based coating material for architectural purposes with the given theoretical spreading rate of 8 m²/l based on this ILC is

for the repeatability limit $r = 0,22 \%$, (absolute)

for the reproducibility limit $R = 0,36 \%$, (absolute)

Bibliography

- [1] ISO 4618:2014, *Paints and varnishes — Terms and definitions*
- [2] ISO 11664-2:2007, *Colorimetry — Part 2: CIE standard illuminants*
- [3] ISO 11664-4:2008, *Colorimetry — Part 4: CIE 1976 L*a*b* Colour space*
- [4] ISO 5725-2, *Accuracy (trueness and precision) of measurement methods and results — Part 2: Basic method for the determination of repeatability and reproducibility of a standard measurement method*
- [5] ISO/TR 22971, *Accuracy (trueness and precision) of measurement methods and results — Practical guidance for the use of ISO 5725-2:1994 in designing, implementing and statistically analysing interlaboratory repeatability and reproducibility results*

标格达仪器
www.biuged.com

标格达仪器
www.biuged.com

标格达仪器
www.biuged.com

标格达仪器
www.biuged.com

标格达仪器
www.biuged.com

标格达仪器
www.biuged.com

标格达仪器
www.biuged.com

标格达仪器
www.biuged.com

标格达仪器
www.biuged.com

标格达仪器
www.biuged.com

标格达仪器
www.biuged.com

标格达仪器
www.biuged.com

标格达仪器
www.biuged.com

标格达仪器
www.biuged.com

标格达仪器
www.biuged.com

This page has been left intentionally blank.

标格达仪器
www.biuged.com

标格达仪器
www.biuged.com

标格达仪器
www.biuged.com

标格达仪器
www.biuged.com

标格达仪器
www.biuged.com