

# Paints and varnishes — Determination of resistance to abrasion —

## Part 2: Rotating abrasive rubber wheel method

The European Standard EN ISO 7784-2:2006 has the status of a British Standard

ICS 87.040

**BS EN ISO  
7784-2:2006**

**BS  
3900-E15:2006**

*Incorporating  
amendment no. 1 to  
BS 3900-E15:1997  
(renumbers the BS  
as BS EN ISO  
7784-2:2006)*

## National foreword

This British Standard was published by BSI. It is the UK implementation of EN ISO 7784-2:2006. It is identical with ISO 7784-2:1997 *Paints and varnishes — Determination of resistance to abrasion — Part 2: Rotating abrasive rubber wheel method* published by the International Organization for Standardization (ISO).

The UK participation in its preparation was entrusted to Technical Committee STI/10, Test methods for paint.

A list of organizations represented on STI/10 can be obtained on request.

This publication does not purport to include all the necessary provisions of a contract. Users are responsible for its correct application.

**Compliance with a British Standard cannot confer immunity from legal obligations.**

This British Standard, having been prepared under the direction of the Sector Board for Materials and Chemicals, was published under the authority of the Standards Board and comes into effect on 15 June 1997

© BSI 2007

ISBN 0 580 27290 7

### Amendments issued since publication

Amd. No.	Date	Comments
16869	28 February 2007	Renumbers the BS as BS EN ISO 7784-2:2006

ICS 87.040

English Version

Paints and varnishes - Determination of resistance to abrasion -  
Part 2: Rotating abrasive rubber wheel method (ISO 7784-  
2:1997)

Peintures et vernis - Détermination de la résistance à  
l'abrasion - Partie 2: Méthode utilisant une roue abrasive en  
caoutchouc (ISO 7784-2:1997)

Beschichtungsstoffe - Bestimmung des Abriebwiderstandes  
- Teil 2: Verfahren mit rotierendem Reibrad mit  
Gummirädern (ISO 7784-2:1997)

This European Standard was approved by CEN on 9 March 2006.

CEN members are bound to comply with the CEN/CENELEC Internal Regulations which stipulate the conditions for giving this European Standard the status of a national standard without any alteration. Up-to-date lists and bibliographical references concerning such national standards may be obtained on application to the Central Secretariat or to any CEN member.

This European Standard exists in three official versions (English, French, German). A version in any other language made by translation under the responsibility of a CEN member into its own language and notified to the Central Secretariat has the same status as the official versions.

CEN members are the national standards bodies of Austria, Belgium, Cyprus, Czech Republic, Denmark, Estonia, Finland, France, Germany, Greece, Hungary, Iceland, Ireland, Italy, Latvia, Lithuania, Luxembourg, Malta, Netherlands, Norway, Poland, Portugal, Romania, Slovakia, Slovenia, Spain, Sweden, Switzerland and United Kingdom.



EUROPEAN COMMITTEE FOR STANDARDIZATION  
COMITÉ EUROPÉEN DE NORMALISATION  
EUROPÄISCHES KOMITEE FÜR NORMUNG

Management Centre: rue de Stassart, 36 B-1050 Brussels

## **Foreword**

The text of ISO 7784-2:1997 has been prepared by Technical Committee ISO/TC 35 "Paints and varnishes" of the International Organization for Standardization (ISO) and has been taken over as EN ISO 7784-2:2006 by Technical Committee CEN/TC 139 "Paints and varnishes", the secretariat of which is held by DIN.

This European Standard shall be given the status of a national standard, either by publication of an identical text or by endorsement, at the latest by October 2006, and conflicting national standards shall be withdrawn at the latest by October 2006.

According to the CEN/CENELEC Internal Regulations, the national standards organizations of the following countries are bound to implement this European Standard: Austria, Belgium, Cyprus, Czech Republic, Denmark, Estonia, Finland, France, Germany, Greece, Hungary, Iceland, Ireland, Italy, Latvia, Lithuania, Luxembourg, Malta, Netherlands, Norway, Poland, Portugal, Romania, Slovakia, Slovenia, Spain, Sweden, Switzerland and United Kingdom.

### **Endorsement notice**

The text of ISO 7784-2:1997 has been approved by CEN as EN ISO 7784-2:2006 without any modifications.

INTERNATIONAL  
STANDARD

**ISO**  
**7784-2**

First edition  
1997-02-15

---

**Paints and varnishes — Determination of  
resistance to abrasion —**

**Part 2:**

Rotating abrasive rubber wheel method

*Peintures et vernis — Détermination de la résistance à l'abrasion —*

*Partie 2: Méthode utilisant une roue abrasive en caoutchouc*



Reference number  
ISO 7784-2:1997(E)

## Foreword

ISO (the International Organization for Standardization) is a worldwide federation of national standards bodies (ISO member bodies). The work of preparing International Standards is normally carried out through ISO technical committees. Each member body interested in a subject for which a technical committee has been established has the right to be represented on that committee. International organizations, governmental and non-governmental, in liaison with ISO, also take part in the work. ISO collaborates closely with the International Electrotechnical Commission (IEC) on all matters of electrotechnical standardization.

Draft International Standards adopted by the technical committees are circulated to the member bodies for voting. Publication as an International Standard requires approval by at least 75 % of the member bodies casting a vote.

International Standard ISO 7784-2 was prepared by Technical Committee ISO/TC 35, *Paints and varnishes*, Subcommittee SC 9, *General test methods for paints and varnishes*.

ISO 7784 consists of the following parts, under the general title *Paints and varnishes — Determination of resistance to abrasion*:

- Part 1: *Rotating abrasive-paper-covered wheel method*;
- Part 2: *Rotating abrasive rubber wheel method*;
- Part 3: *Reciprocating test panel method*.

Annex A forms an integral part of this part of ISO 7784. Annex B and Annex C are for information only.

**Descriptors:** Paints, varnishes, paint coats, tests, wear tests, abrasion tests, determination, wear resistance, abrasion resistance, test equipment.

## Introduction

This document is one of three parts of ISO 7784 dealing with the determination of resistance to abrasion of a dried film of paint, varnish or related product.

Parts 1 and 3 both specify a method using abrasive paper for determination of the resistance to abrasion. In part 2, a method using abrasive rubber wheels is described. The user of ISO 7784 should note that the methods using abrasive paper (parts 1 and 3) are the preferred methods.

### 1 Scope

This part of ISO 7784 is one of a series of standards dealing with the sampling and testing of paints, varnishes and related products.

This part of ISO 7784 specifies a method for determining the resistance to abrasion of a dried film of paint, varnish or related product, using abrasive rubber wheels and abrading by making a rotary movement.

### 2 Normative references

The following standards contain provisions which, through reference in this text, constitute provisions of this part of ISO 7784. At the time of publication, the editions indicated were valid. All standards are subject to revision, and parties to agreements based on this part of ISO 7784 are encouraged to investigate the possibility of applying the most recent editions of the standards indicated below. Members of IEC and ISO maintain registers of currently valid International Standards.

ISO 48:1994, *Rubber — Determination of hardness (hardness between 30 and 85 IRHD)*.

ISO 1512:1991, *Paints and varnishes — Sampling of products in liquid or paste form*.

ISO 1513:1992, *Paints and varnishes — Examination and preparation of samples for testing*.

ISO 1514:1993, *Paints and varnishes — Standard panels for testing*.

ISO 2808:—<sup>1)</sup>, *Paints and varnishes — Determination of film thickness*.

ISO 6507-1:1982, *Metallic materials — Hardness test — Vickers test — Part 1: HV 5 to HV 100*.

## 3 Principle

A dried paint or varnish film is abraded, under specified conditions, with abrasive rubber wheels which are attached to an abrasion testing machine. During the test the wheels are loaded with specified weights. The resistance to abrasion is calculated as the loss in mass after a specified number of abrasion cycles or as the number of cycles required to remove the coating down to the next layer or down to the substrate.

## 4 Required supplementary information

For any particular application, the test method specified in this part of ISO 7784 needs to be completed by supplementary information. The items of supplementary information are given in Annex A.

## 5 Apparatus

**5.1 Abrasion testing machine<sup>2)</sup>**, consisting of the elements described in **5.1.1** to **5.1.4** (see also Figure 1).

**5.1.1 Turntable**, capable of rotating at a speed of  $(60 \pm 2)$  rpm, on which the test panel can be centrally mounted and firmly attached.

**5.1.2 Two abrasive rubber wheels<sup>2)</sup>**, each of thickness  $(12,7 \pm 0,1)$  mm. The wheels shall be mounted on and able to rotate freely about horizontal spindles. Their internal faces shall be  $(53,0 \pm 0,5)$  mm apart and the hypothetical line through the two spindles shall be  $(19,1 \pm 0,1)$  mm away from the central axis of the turntable. The external diameter of the wheels shall be  $(51,6 \pm 0,1)$  mm when new, and in no case less than 44,4 mm.

The type of wheel shall be chosen by agreement between the interested parties.

A slow hardening of the rubber bonding material in this type of wheel may occur. Therefore the hardness shall be checked to agree with the specification given by the manufacturer. Wheels shall not be used after the expiration date marked on them by the manufacturer, or more than one year after their purchase if no expiration date is given.

**5.1.3 Counter**, to record the number of cycles (turns) made by the turntable.

<sup>1)</sup> To be published. (Revision of ISO 2808:1991)

<sup>2)</sup> This apparatus is commercially available from Teledyne Taber, 455 Bryant Street, North Tonawanda, NY 14120, USA.

**5.1.4 Suction device**, with two nozzles. One of the nozzles shall be positioned between the two wheels and the other placed diametrically opposite the first. The distance between the axes of the two nozzles shall be  $(75 \pm 2)$  mm and the distance between them and the test panel 1 mm to 2 mm.

When the suction nozzles are in position, the air pressure in the suction device shall be  $1,5 \text{ kPa}^{3)}$  to  $1,6 \text{ kPa}^{3)}$  lower than atmospheric pressure.

**5.2 Weights**, to enable the mass of each wheel to be increased by up to 1 kg.

**5.3 Resurfacing medium**, in the form of an abrasive disc, used for resurfacing the wheels.

**5.4 Calibration panel**, of thickness between 0,8 mm and 1 mm, for calibration of the apparatus (see Annex B).

**5.5 Balance**, with an accuracy of 0,1 mg.

## 6 Sampling

Take a representative sample of the product to be tested (or of each product in the case of a multi-coat system), as described in ISO 1512.

Examine and prepare each sample for testing, as described in ISO 1513.

## 7 Test panels

### 7.1 Substrate

Unless otherwise agreed, select the substrate from one of those described in ISO 1514, using, where possible, the same type of material as will be used in practice. The substrate panels shall be plane and free from distortion, otherwise the wear of the coating under test will not be uniform.

### 7.2 Shape and dimensions

The shape and dimensions of the test panels shall be such that they can be fitted correctly on the apparatus. They shall have a central hole of diameter 6,35 mm.

NOTE Typical dimensions for a test panel are  $100 \text{ mm} \times 100 \text{ mm}$ .

### 7.3 Preparation and coating

Unless otherwise agreed, prepare each test panel in accordance with ISO 1514 and then coat it by the specified method with the product or system under test.

## 7.4 Drying and conditioning

Dry (or stove) and age, if applicable, each coated test panel for the specified time under the specified conditions.

## 7.5 Thickness of coating

Determine the thickness, in micrometres, of the dried coating by one of the methods specified in ISO 2808.

## 8 Procedure

### 8.1 Test conditions

Carry out the test at a temperature of  $(23 \pm 2) ^\circ\text{C}$  and a relative humidity of  $(50 \pm 5) \%$ , unless otherwise agreed.

### 8.2 Calibration of the apparatus

Calibrate the apparatus (an example of a calibration procedure is given in Annex B).

### 8.3 Preparation of the abrading rubber wheels

**8.3.1** Check that the abrasive rubber wheels meet the requirements specified in **5.1.2**.

**8.3.2** To ensure that the abrading function of the wheels is maintained at a constant level, prepare the abrasive rubber wheels as prescribed by the manufacturer, following **8.3.2.1** to **8.3.2.4**.

**8.3.2.1** Mount the selected abrasive rubber wheels on their respective flange holders, taking care not to touch the abrasive surfaces. Adjust the load on the wheels to the value agreed between the interested parties.

**8.3.2.2** Mount the resurfacing-medium disc on the turntable. Lower the abrading heads carefully until the wheels rest on the disc. Place the suction nozzle in position and adjust it to a distance of 1 mm above the surface of the disc.

**8.3.2.3** Set the counter to zero.

**8.3.2.4** Start up the suction and then the turntable. Resurface the wheels by running them for a specified number of cycles against the resurfacing-medium disc.

NOTE A typical number of cycle is 50.

Resurface the wheels in this manner before testing each specimen and after every 500 cycles, in such a way that the abrasive surface is exactly cylindrical and that the edges between the abrasive surface and the side faces are sharp, without any bending radius. Resurface new wheels before the first use.

<sup>3)</sup> 1 kPa = 10 mbar.



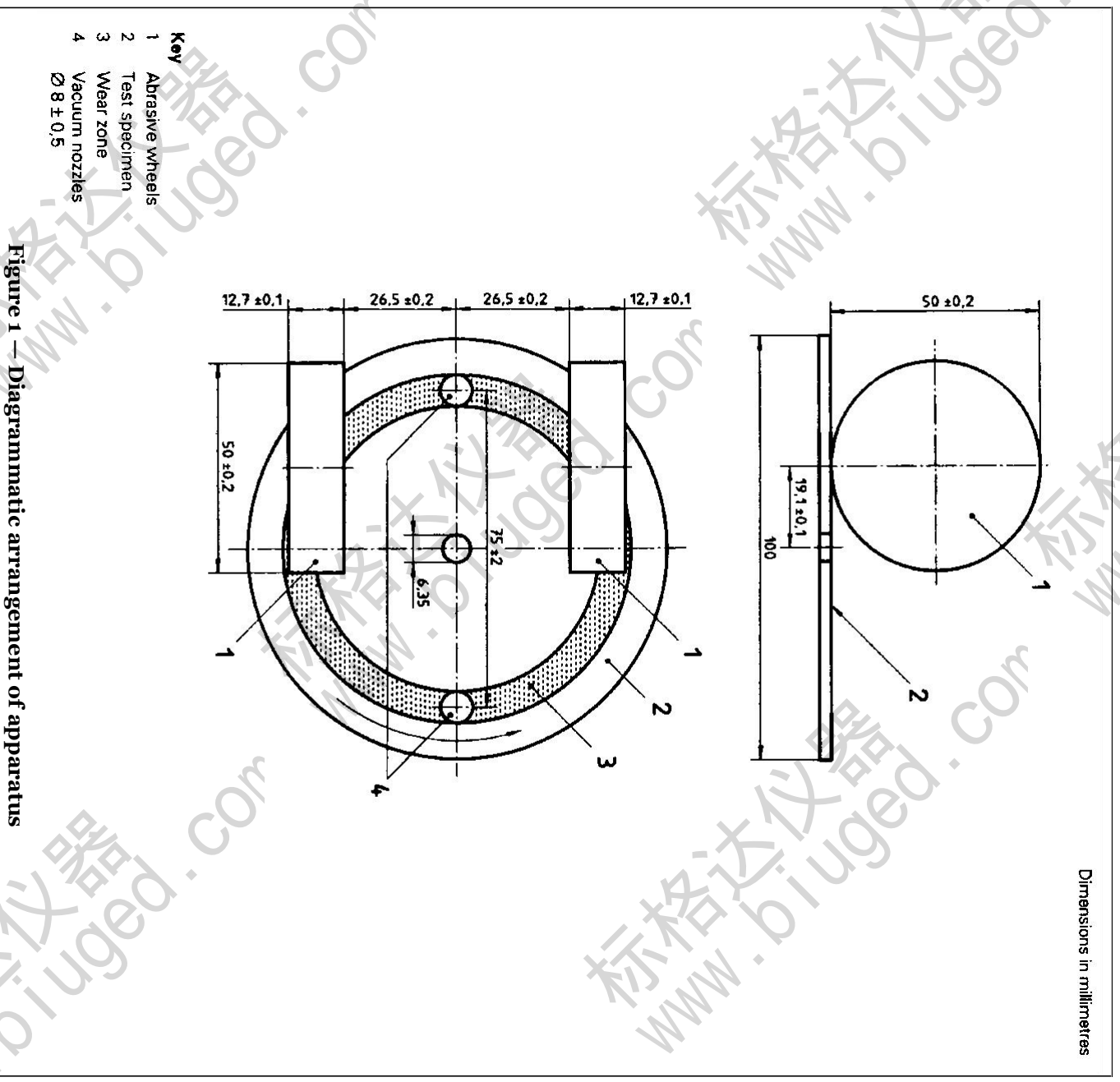

## 8.4 Determination

**8.4.1** Condition the coated test panels at a temperature of  $(23 \pm 2)$  °C and a relative humidity of  $(50 \pm 5)$  %, unless otherwise agreed, for a minimum period of 16 h.

**8.4.2** If the surface of the coating is irregular, due to orange peel, brush marks, etc., abrade it for 50 cycles and clean it with lint-free paper prior to the determination. Report this operation, if carried out, in the test report.

**8.4.3** Weigh the conditioned test panel to the nearest 0,1 mg, and record this mass.

**8.4.4** Attach the test panel to the turntable, lower the abrading heads on to the test panel and place the suction nozzles in position.

**8.4.5** Set the counter to zero and start up the suction and then the turntable.

**8.4.6** After a specified number of cycles, remove any loose abrasings remaining on the test panel with lint-free paper, reweigh the test panel and record this mass. Inspect the panel to see if wearthrough of the coating has occurred.

**8.4.7** By interrupting the test at intervals, the point of wearthrough can be determined more accurately and the average loss in mass for a given number of cycles can be calculated.

**8.4.8** Repeat **8.4.2** to **8.4.6** for two more test panels and record the results.

## 9 Expression of results

**9.1** For each test panel, calculate the loss in mass after the agreed number of cycles by subtraction.

Calculate the mean loss in mass for all three test panels and report the result to the nearest 1 mg.

NOTE The loss in mass can also be calculated at each of the intervals at which the test was interrupted.

**9.2** Calculate the mean number of cycles required to reach wearthrough of the coating or of the topcoat in a multicoat system.

NOTE After the wearthrough of the coating, the loss in mass is affected by abrasion of the substrate.

## 10 Precision

See Annex C.

## 11 Test report

The test report shall contain at least the following information:

- a) all details necessary to identify the product tested;
- b) reference to this part of ISO 7784 (ISO 7784-2);
- c) the items of supplementary information referred to in Annex A;
- d) a reference to the international or national standard, product specification or other document supplying the information referred to in c);
- e) the wheel load and the type of abrasive rubber wheel used;
- f) the results of the test as indicated in clause 9;
- g) whether the surface had to be pre-abraded because of surface irregularities;
- h) any deviation from the test method specified;
- i) the date of the test.

## Annex A (normative) Required supplementary information

The items of supplementary information listed in this annex shall be supplied as appropriate to enable the method to be carried out.

The information required should preferably be agreed between the interested parties and may be derived, in part or totally, from an international or national standard or other document related to the product under test.

- a) Substrate material, substrate thickness and surface preparation of the substrate.
- b) Method of application of the test coating to the substrate, including the duration and conditions of drying between coats in the case of a multi-coat system.
- c) Duration and conditions of drying (or stoving) and ageing, if applicable, of the coating before testing.
- d) Thickness, in micrometres, of the dry coating and the method of measurement in accordance with ISO 2808, and whether it is a single coat or a multi-coat system.
- e) Temperature and humidity during the test, if different from those specified in **8.1**.

## Annex B (informative) Calibration of the apparatus

### B.1 General

The accessories needed for calibration, such as calibration panels and the abrasive paper, should preferably be obtained from the manufacturer of the abrasion tester. Usually, zinc panels are delivered as calibration panels by the manufacturer.

### B.2 Apparatus

Apparatus as described in clause **5**, and in addition the following.

**B.2.1** *Two rubber wheels*, each of thickness  $(12,7 \pm 0,1)$  mm and overall diameter  $(50,0 \pm 0,2)$  mm, the periphery of which is covered with a rubber strip of thickness 6 mm and hardness  $(50 \pm 5)$  IRHD (determined in accordance with ISO 48). The wheels shall be mounted on and able to rotate freely about horizontal spindles.

Their internal faces shall be  $(53,0 \pm 0,5)$  mm apart and the hypothetical line through the two spindles shall be  $(19,1 \pm 0,1)$  mm away from the central axis of the turntable. The mass distribution within the assembly shall be such that each of the wheels exerts a force of  $(1 \pm 0,02)$  N on the test panel.

**B.2.2** *Strips of abrasive paper*, of width  $(12 \pm 0,2)$  mm and approximate length 175 mm. The grade of abrasive paper shall be P 180 as defined in the P series of the grain size standard published by the Federation of European Producers of Abrasive Products (FEPA).<sup>4)</sup>

NOTE Self-adhesive abrasive paper is also available from some manufacturers.

**B.2.3** *Double-sided adhesive tape*, in strips of width  $(12 \pm 0,2)$  mm and approximate length 175 mm, for use if self-adhesive abrasive paper is not available.

### B.3 Calibration procedure

**B.3.1** Condition the abrasive paper, the adhesive tape, if used, and the test panel at a temperature of  $(23 \pm 2)$  °C and a relative humidity of  $(50 \pm 5)$  %, unless otherwise agreed, for a minimum period of 16 h.

**B.3.2** Attach a conditioned abrasive-paper strip to the circumference of the wheels, using the conditioned adhesive tape, if necessary. Adjust the length of each strip so that it covers the peripheral surface of the wheel without any overlap or gap.

NOTE It is recommended that the strips be cut at an angle of approximately 45° so that the joint is not at right angles to the direction of travel of the wheels (see Figure B.1).

**B.3.3** If a new zinc panel is being used, abrade it for 200 cycles of the turntable before use, following the procedure specified in **B.3.5** and **B.3.6**, and then clean it with lint-free paper.

**B.3.4** Weigh the conditioned test panel to the nearest 1 mg, and record this mass.

**B.3.5** Install a 500 g load on each arm of the abrasion testing machine, attach the test panel to the turntable, lower the abrading heads on to the test panel and place the suction nozzles in position.

**B.3.6** Set the counter to zero and start up the suction and then the turntable.

**B.3.7** After 500 cycles, clean the test panel with lint-free paper, reweigh the test panel and record this mass.

**B.3.8** Carry out **B.3.2** to **B.3.7** twice more, each time with a new strip of abrasive paper.

**B.3.9** After the third test, calculate the mean loss in mass for the three calibration runs.

**B.3.10** The average loss in mass of the zinc plate should be  $(110 \pm 30)$  mg. If the average loss in mass is outside this range, check the apparatus and rectify any faults.

<sup>4)</sup> FEPA Standard 43-GB-1984, obtainable from the British Abrasive Federation, P.O. Box 58, Trafford Park Road, Trafford Park, Manchester M17 1JD, United Kingdom.

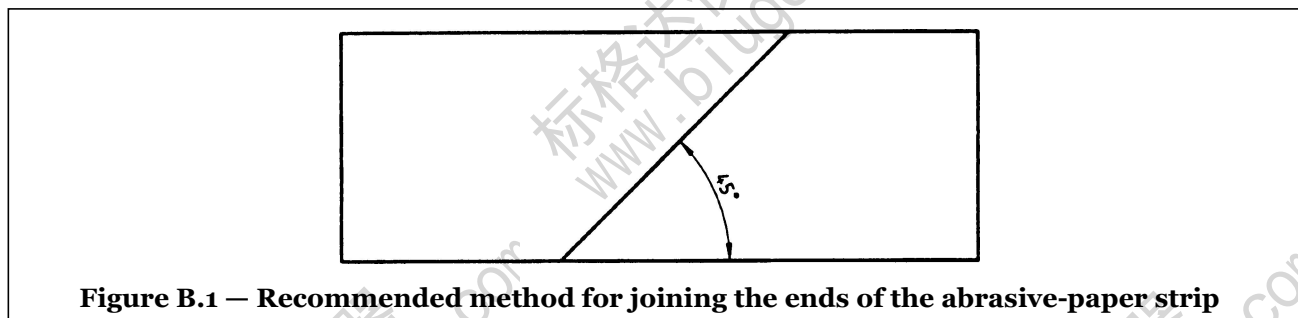

Figure B.1 – Recommended method for joining the ends of the abrasive-paper strip

## Annex C (informative)

### Precision

No relevant precision data are currently available.

If numerical values are to be measured, this method should be performed in only one laboratory. In case of work between laboratories, it is better to use rankings for the coatings.

ISO/TC 35 intends to obtain precision data for all relevant standards, including this part of ISO 7784.

When precision data are available, they will be incorporated in the document.

blank



---

---

## **BSI — British Standards Institution**

BSI is the independent national body responsible for preparing British Standards. It presents the UK view on standards in Europe and at the international level. It is incorporated by Royal Charter.

### **Revisions**

British Standards are updated by amendment or revision. Users of British Standards should make sure that they possess the latest amendments or editions.

It is the constant aim of BSI to improve the quality of our products and services. We would be grateful if anyone finding an inaccuracy or ambiguity while using this British Standard would inform the Secretary of the technical committee responsible, the identity of which can be found on the inside front cover. Tel: +44 (0)20 8996 9000. Fax: +44 (0)20 8996 7400.

BSI offers members an individual updating service called PLUS which ensures that subscribers automatically receive the latest editions of standards.

### **Buying standards**

Orders for all BSI, international and foreign standards publications should be addressed to Customer Services. Tel: +44 (0)20 8996 9001. Fax: +44 (0)20 8996 7001. Email: [orders@bsi-global.com](mailto:orders@bsi-global.com). Standards are also available from the BSI website at <http://www.bsi-global.com>.

In response to orders for international standards, it is BSI policy to supply the BSI implementation of those that have been published as British Standards, unless otherwise requested.

### **Information on standards**

BSI provides a wide range of information on national, European and international standards through its Library and its Technical Help to Exporters Service. Various BSI electronic information services are also available which give details on all its products and services. Contact the Information Centre. Tel: +44 (0)20 8996 7111. Fax: +44 (0)20 8996 7048. Email: [info@bsi-global.com](mailto:info@bsi-global.com).

Subscribing members of BSI are kept up to date with standards developments and receive substantial discounts on the purchase price of standards. For details of these and other benefits contact Membership Administration. Tel: +44 (0)20 8996 7002. Fax: +44 (0)20 8996 7001. Email: [membership@bsi-global.com](mailto:membership@bsi-global.com).

Information regarding online access to British Standards via British Standards Online can be found at <http://www.bsi-global.com/bsonline>.

Further information about BSI is available on the BSI website at <http://www.bsi-global.com>.

### **Copyright**

Copyright subsists in all BSI publications. BSI also holds the copyright, in the UK, of the publications of the international standardization bodies. Except as permitted under the Copyright, Designs and Patents Act 1988 no extract may be reproduced, stored in a retrieval system or transmitted in any form or by any means – electronic, photocopying, recording or otherwise – without prior written permission from BSI.

This does not preclude the free use, in the course of implementing the standard, of necessary details such as symbols, and size, type or grade designations. If these details are to be used for any other purpose than implementation then the prior written permission of BSI must be obtained.

Details and advice can be obtained from the Copyright & Licensing Manager. Tel: +44 (0)20 8996 7070. Fax: +44 (0)20 8996 7553. Email: [copyright@bsi-global.com](mailto:copyright@bsi-global.com).