

INTERNATIONAL  
STANDARD

ISO  
17872

Second edition  
2019-08

---

**Paints and varnishes — Guidelines  
for the introduction of scribe marks  
through coatings on metallic panels  
for corrosion testing**

*Peintures et vernis — Lignes directrices pour la production de rayures  
au travers du revêtement de panneaux métalliques en vue des essais  
de corrosion*



Reference number  
ISO 17872:2019(E)

© ISO 2019



**COPYRIGHT PROTECTED DOCUMENT**

© ISO 2019

All rights reserved. Unless otherwise specified, or required in the context of its implementation, no part of this publication may be reproduced or utilized otherwise in any form or by any means, electronic or mechanical, including photocopying, or posting on the internet or an intranet, without prior written permission. Permission can be requested from either ISO at the address below or ISO's member body in the country of the requester.

ISO copyright office  
CP 401 • Ch. de Blandonnet 8  
CH-1214 Vernier, Geneva  
Phone: +41 22 749 01 11  
Fax: +41 22 749 09 47  
Email: [copyright@iso.org](mailto:copyright@iso.org)  
Website: [www.iso.org](http://www.iso.org)

Published in Switzerland

# Contents

	Page
Foreword .....	iv
Introduction .....	v
1 Scope .....	1
2 Normative references .....	1
3 Terms and definitions .....	1
4 Scribe marks .....	1
5 Apparatus .....	5
6 Test panels .....	6
7 Procedure .....	6
8 Verification of the scribing tool .....	6
9 Report .....	6
Annex A (informative) Scribing tools .....	8
Annex B (informative) Examples of possible different results in one corrosion test when using different scribing tools .....	17
Bibliography .....	23

## Foreword

ISO (the International Organization for Standardization) is a worldwide federation of national standards bodies (ISO member bodies). The work of preparing International Standards is normally carried out through ISO technical committees. Each member body interested in a subject for which a technical committee has been established has the right to be represented on that committee. International organizations, governmental and non-governmental, in liaison with ISO, also take part in the work. ISO collaborates closely with the International Electrotechnical Commission (IEC) on all matters of electrotechnical standardization.

The procedures used to develop this document and those intended for its further maintenance are described in the ISO/IEC Directives, Part 1. In particular, the different approval criteria needed for the different types of ISO documents should be noted. This document was drafted in accordance with the editorial rules of the ISO/IEC Directives, Part 2 (see [www.iso.org/directives](http://www.iso.org/directives)).

Attention is drawn to the possibility that some of the elements of this document may be the subject of patent rights. ISO shall not be held responsible for identifying any or all such patent rights. Details of any patent rights identified during the development of the document will be in the Introduction and/or on the ISO list of patent declarations received (see [www.iso.org/patents](http://www.iso.org/patents)).

Any trade name used in this document is information given for the convenience of users and does not constitute an endorsement.

For an explanation of the voluntary nature of standards, the meaning of ISO specific terms and expressions related to conformity assessment, as well as information about ISO's adherence to the World Trade Organization (WTO) principles in the Technical Barriers to Trade (TBT) see [www.iso.org/iso/foreword.html](http://www.iso.org/iso/foreword.html).

This document was prepared by Technical Committee ISO/TC 35, *Paints and varnishes*, Subcommittee SC 9, *General test methods for paints and varnishes*.

This second edition cancels and replaces the first edition (ISO 17872:2007), which has been technically revised. The main changes compared to the previous edition are as follows:

- [Clause 2](#), "Normative references" and [Clause 3](#), "Terms and definitions" have been added;
- figures of L-shaped and diagonal shaped scribes have been added;
- a second variation of the cross-sectional shape of U-shape scribe mark has been added in [Figure 2](#);
- V-shape replaceable blade, disc milling cutter, graver and ceramic knife have been added to the list of possible cutting tools;
- pictures of the cross sections have been added to the corresponding cutting tools;
- the examples for cutting tools in [Table A.1](#) have been grouped to knife or blade tools, pencil type tools and milling machines;
- the original [Annex B](#) has been replaced by a new annex on examples of possible different results in one corrosion test when using different scribing tools.

Any feedback or questions on this document should be directed to the user's national standards body. A complete listing of these bodies can be found at [www.iso.org/members.html](http://www.iso.org/members.html).

## Introduction

Many International Standards deal with corrosion testing, where scribe marks are introduced through a coating to a metallic substrate. However, the method of scribe-mark introduction (scribing pattern, tools, etc.) is not standardized across these standards.

The main purposes of an intentionally inflicted damage in a coating prior to corrosion testing are as follows:

- a) to simulate and to investigate how adhesion of a coating originating from an artificial damage after exposure is ensured;
- b) to obtain an accelerated response during a corrosion test, e.g. at quality control during production;
- c) to investigate the general durability of a coating by observation of the rate of corrosion at a damage spread after exposure.

Preliminary investigations have shown that several variants, both in terms of shape and dimensions, of scribing tools are used. These variations occur both across countries and within countries. The effect of using different tools is the production of scribe marks with different cross-sectional shape, depth and exposed metal area. These differences will greatly affect test results obtained during corrosion tests, as the intention of introducing scribe marks into a coating system is such that oxygen and the electrolyte present during exposure testing can obtain access to a well-defined and active metal surface.

The actual method used to introduce a scribe mark depends on the coating type and thickness. However, in all cases it is preferable if the cross-section is as smooth as possible, the metallic substrate is exposed evenly and no coating remains on the exposed substrate.

标格达仪器  
www.biuged.com

标格达仪器  
www.biuged.com

标格达仪器  
www.biuged.com

标格达仪器  
www.biuged.com

标格达仪器  
www.biuged.com

标格达仪器  
www.biuged.com

标格达仪器  
www.biuged.com

标格达仪器  
www.biuged.com

标格达仪器  
www.biuged.com

标格达仪器  
www.biuged.com

# Paints and varnishes — Guidelines for the introduction of scribe marks through coatings on metallic panels for corrosion testing

## 1 Scope

This document describes methods of scribing coated steel or test-pieces for corrosion tests, where the coating system is applied at dry film thicknesses of less than 500 µm. It is intended as a guideline only, being based on the results of a collaborative trial with no subsequent corrosion testing having been carried out to determine the suitability of the introduced scribe marks for such tests.

This document covers the scribing of metallic panels or test pieces (chemically treated or not) made from:

- steel;
- galvanized steel;
- aluminium alloys;
- magnesium alloys.

It does not cover the scribing of electroplated metal or clad aluminium panels.

## 2 Normative references

The following documents are referred to in the text in such a way that some or all of their content constitutes requirements of this document. For dated references, only the edition cited applies. For undated references, the latest edition of the referenced document (including any amendments) applies.

ISO 4618, *Paints and varnishes — Terms and definitions*

## 3 Terms and definitions

For the purposes of this document, the terms and definitions given in ISO 4618 apply.

ISO and IEC maintain terminological databases for use in standardization at the following addresses:

- ISO Online browsing platform: available at <https://www.iso.org/obp>
- IEC Electropedia: available at <http://www.electropedia.org/>

## 4 Scribe marks

Different scribe marks create different results depending on the used corrosion test.

The scribing method greatly affects how the corrosion process occurs and the reproducibility when tests are repeated under the same conditions. Examples of possible different results in one corrosion test when using different scribing tools are given in [Annex B](#). In order to obtain results with high accuracy and reproducibility, accurate and consistent scribing is required.

If not otherwise agreed or specified, a scribe mark is made as described in [Figure 1a\)](#) to [Figure 1e\)](#) through the coating to the metal substrate according to the agreed conditions. For hot-dip galvanized steel the scribe shall be cut completely through the paint coating and the metal layer and into the steel substrate, as specified in ISO 12944-6 and ISO 12944-9.

Typically, the suitable length of the scribed lines is in the range of 50 mm to 70 mm, depending on the coating thickness and the expected amount of corrosion. The length of the scribe mark should be significantly more than the expected creep resulting from the corrosion test carried out. It should give an overview what happens on the surface of the system. Too short scribing lengths have an impact on the results.

The width of the scribe mark can also affect the result of a corrosion test. The smaller the width, the stronger is the tendency for the exposed metal surface to be passivated by deposition of sparingly soluble corrosion products. Kind and thickness of an organic coating can have an impact to the scribing line in that way that the scribing line closes itself partially in kind of a capillary. Therefore, no or less electrolytes and/or oxygen could reach the metal surface. It is therefore important to select a scribing tool which will provide a suitable scribe width for the corrosion test being carried out.

The orientation of the scribed lines is often significant in terms of affecting corrosion test results. On panels with a slight inclination from the vertical, e.g. for salt-spray tests, more salt is collected in a horizontally exposed scribe mark. Also, a horizontally exposed scribe mark will generate an even salt distribution, whereas a diagonal, or more particularly a vertical, scribe mark tends to generate a gradient, with an increasing amount of salt along the lower edge of the scribe mark. An increased amount of salt usually leads to an increased corrosion rate, but on coated steel, high salt concentration might have an inhibiting effect on corrosion since the formed corrosion products are very dense.

Milled/rolled aluminium substrates shall get basically two scribes in different orientations to consider the influence of the milling/rolling direction to the corrosion result.

The cross-section of the scribe mark should be as uniform as possible along its entire length. The coating should be cut smoothly along the direction of the scribe mark. The cross-sectional shape of the scribe may be either "V" or "U" shaped, depending upon the tool used, and should be such that for a "V"-shaped cut  $a > b > c$  and for a "U"-shaped cut  $a > b$ , with the width ( $b$ ) of both "V" and "U" shapes such that  $b \geq 0,2$  mm (see [Figure 2](#) for an explanation of the symbols). Certain scribing tools can also produce a rectangular cross-section, where  $a$ ,  $b$  and  $c$  are approximately equal (one example is the "U"-shaped cut variation 2).

The shape, depth and uniformity of scribe marks resulting from the use of manual scribing tools will also depend on the operator carrying out the scribing procedure. To reduce this operator dependency, and hence variability in subsequent corrosion test results, automatic scribing machines may also be used to introduce scribe marks, provided they produce a scribe mark which penetrates to the substrate. Such machines are able to introduce rectangular shaped scribe marks, where the dimensions  $a$ ,  $b$  and  $c$  are approximately equal and each is greater than 0,5 mm.



Dimensions in millimetres

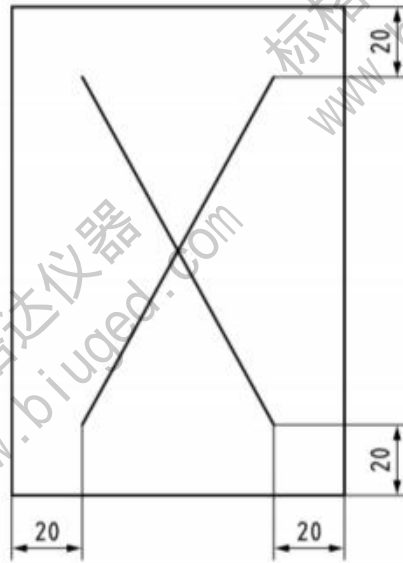

NOTE 1 When evaluating the X-shape scribe in accordance with ISO 4628-8, the section of scribe at the intersection is ignored. Overlapping can happen.

a) X-shape

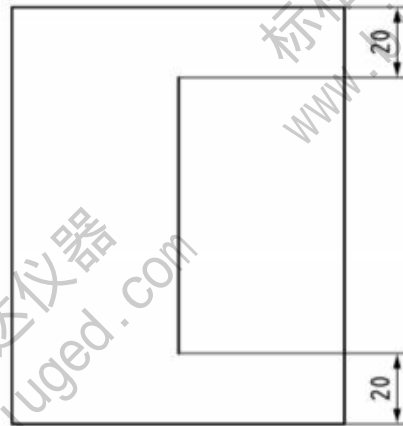

The scribe should be located centrally on the plate to meet the minimum distance of 20 mm to the edge.

b) Single line

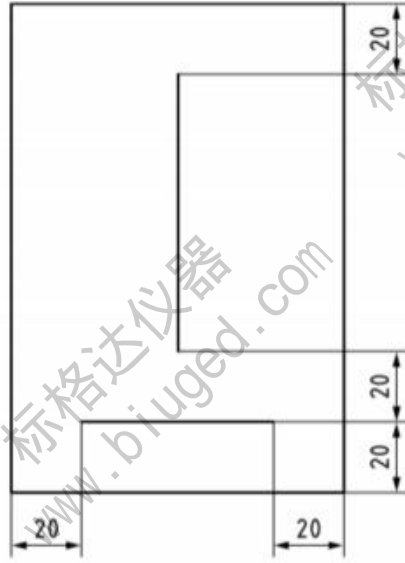

The scribe parallel to the longer side of the panel should be located centrally on the plate to meet the minimum distance of 20 mm to the edge.

c) T-shape

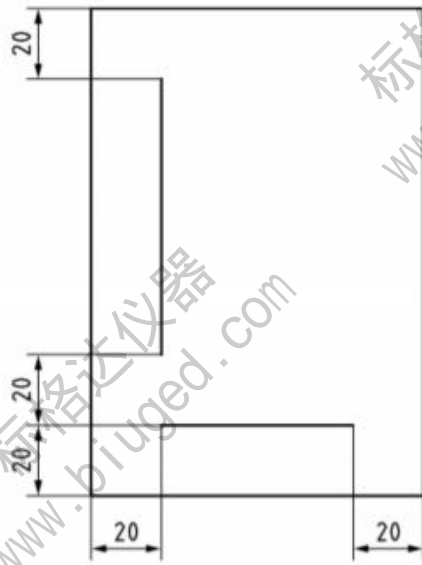

d) L-shape

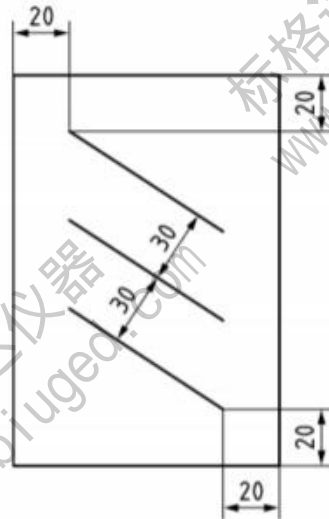

NOTE 2 This shape is used especially for eliminating the influence of the rolling direction of aluminium.

e) Diagonal shape

Figure 1 — Surface shape of scribe marks on coated panels

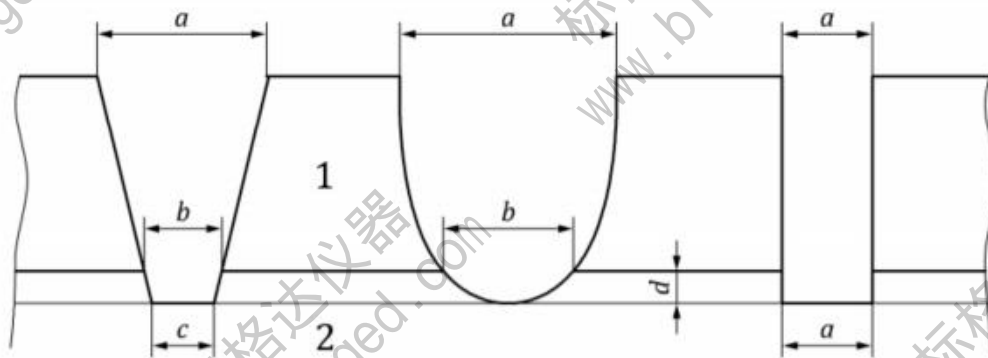

a) "V"-shaped cut      b) "U"-shaped cut variation 1      c) "U"-shaped cut variation 2

Key

- 1 coating
- 2 substrate
- a width of scribe mark at surface of coating
- b width of scribe mark at coating/substrate boundary
- c width of scribe mark at maximum penetration into substrate
- d penetration of scribe mark into substrate

Figure 2 — Cross-sectional shape of scribe mark through a coating

## 5 Apparatus

5.1 **Scribing tool**, see [Annex A](#). Examples of commonly used scribing tools are listed in [Table A.1](#).

5.2 **Metal rule**, to aid the introduction of a straight scribe mark of the specified length.

**5.3 Magnification lens**,  $\times 5$  to  $\times 10$  magnification, to visually ensure uniformity of the scribe and removal of debris (see [Clause 7](#)).

## 6 Test panels

Use a coated panel (or test piece) appropriate for carrying out the corrosion-resistance test.

## 7 Procedure

Ensure that the test panel is firmly secured while the scribe mark is being introduced to ensure uniform location and to prevent panel/tool slippage.

Use the scribing tool to introduce the scribe mark through the coating to the metallic substrate. When scribing, use the metal rule to guide the scribing tool and use a continuous scribing action with uniform speed. Take care not to damage the surrounding coating whilst introducing the scribe mark.

It is preferable that the scribe mark be introduced through the coating to the metal substrate in one smooth action. If this is not possible, actions should be repeated, taking care to follow the cross-section of the previous actions. This should be recorded in the test report. An automated scribing machine may be used.

The edges of the scribe mark should be uniform and should completely penetrate the coating. Remove debris from the scribed mark.

The scribe should be done directly before starting the corrosion stress.

Ensuring uniformity of the scribe mark and complete removal of debris may be aided by viewing with a  $\times 5$  to  $\times 10$  magnification lens.

## 8 Verification of the scribing tool

The scribing tool can become blunt with use and therefore the blade/point should be regularly visually inspected, replaced periodically or, if possible, sharpened.

## 9 Report

A report of the procedure used for scribing should be prepared, including at least the following information:

- a) all information necessary for identification of the sample tested, including:
  - 1) details of substrate material, and surface preparation prior to coating, and
  - 2) all details necessary to identify the coating system tested;
- b) a reference to this document and its year of publication (ISO 17872:2019);
- c) a reference to the International Standard by which the scribed panels will be tested;
- d) details of coating thickness;
- e) the scribing tool used;
- f) the shape and dimensions of the scribe mark;
- g) the orientation of the scribe mark during the test;
- h) any deviations from the procedure specified;

- i) any unusual features (anomalies) observed during the test.

**Annex A**  
(informative)

**Scribing tools**

Examples of commonly used scribing tools are listed in [Table A.1](#).

Table A.1 — Examples of commonly used scribing tools



Dimensions in millimetres					
Tools	Country	Material	Possible scribe width mm	Remarks	Cross section examples <sup>b</sup>
<b>Knife or blade tools</b>					
 <p>a) Cutter, version A: Cutter 301®</p>	Korea	Carbon steel	0,1 to 0,2	Not recommendable for thick coatings (>150 µm) and blasted steel surfaces (= rough surface).	
 <p>c) Version 1: P-800®</p>	Japan	Tungsten steel	0,1 to 0,2	Not recommendable for thick coatings (>150 µm) and blasted steel surfaces (= rough surface).	

Table A.1 (continued)

Tool <sup>a</sup>	Country	Material	Possible scribe width mm	Remarks	Cross section examples <sup>b</sup>
 <p>d) Utility knife (Stanley®)</p>	South Africa	Carbon steel	0,1 to 0,2	Not recommended for thick coatings (>150 µm). Similar to cutter a).	
 <p>e) Ceramic knife</p>	Germany	Ceramic	0,2 to 0,3	For magnesium substrates only.	

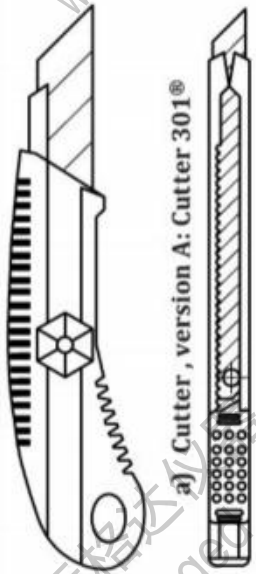

Table A.1 (continued)

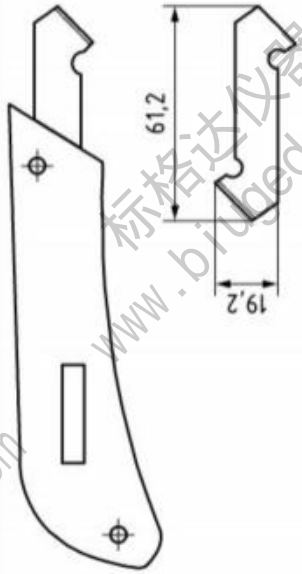
Tools <sup>a</sup>	Country	Material	Possible scribe width mm	Remarks	Cross section examples <sup>b</sup>
 <p>Key 1 replaceable blade 1,0 mm 2 replaceable blade 0,5 mm f) Sikkens®</p>	Germany	Tungsten carbide	0,5 / 1,5 / 1,0 / 2 (depending on blade used)	Easy to handle, smooth cuts.	

Table A.1 (continued)

Tool <sup>a</sup>	Country	Material	Possible scribe width mm	Remarks	Cross section examples <sup>b</sup>
 <p>g) V-shape replaceable blade</p>	US	Carbide steel	0,2 to 0,3		 <p>Type g on steel</p> <p>Type g on galvanized steel</p>

Table A.1 (continued)

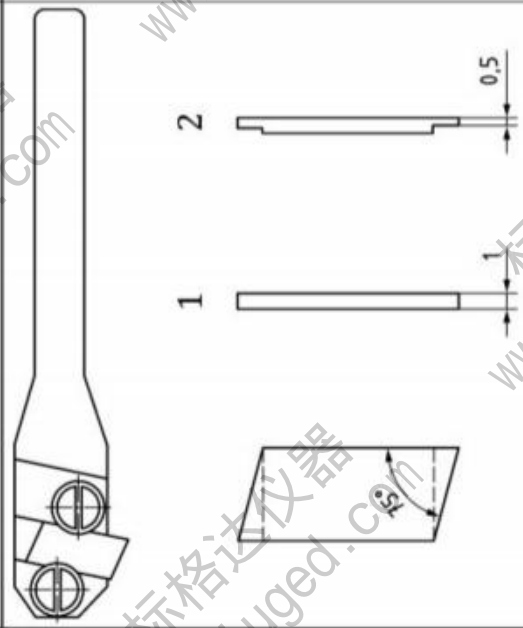
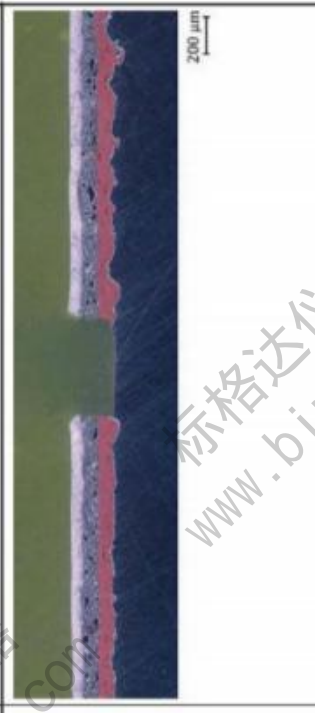

Tools <sup>a</sup>	Country	Material	Possible scribe width mm	Remarks	Cross section examples <sup>b</sup>
Pencil type tools					
  h) ECLIPSE E225®	UK	Tungsten carbide	0,2		
 X	Germany	Tungsten carbide	0,4 to 0,6	Scribe width depends on coating. Original scribe width is determined under microscope. Damage of scribing edges can simulate a wider scribe, but the damage isn't done down to the substrate.	
 i) Clemen®					

Table A.1 (continued)

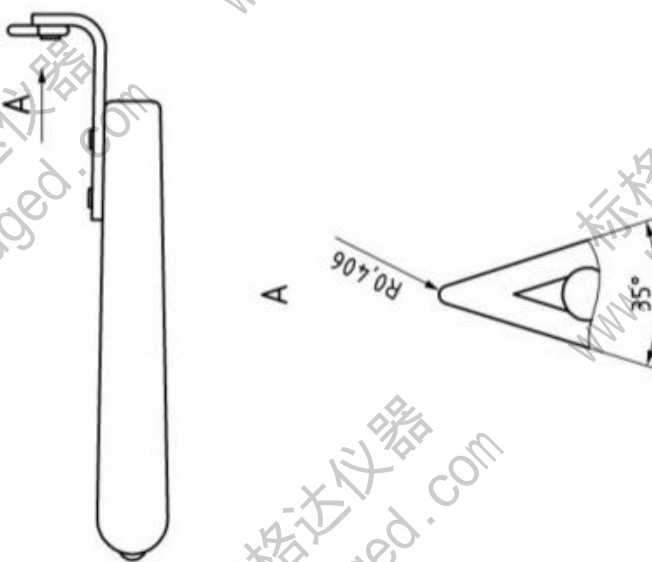
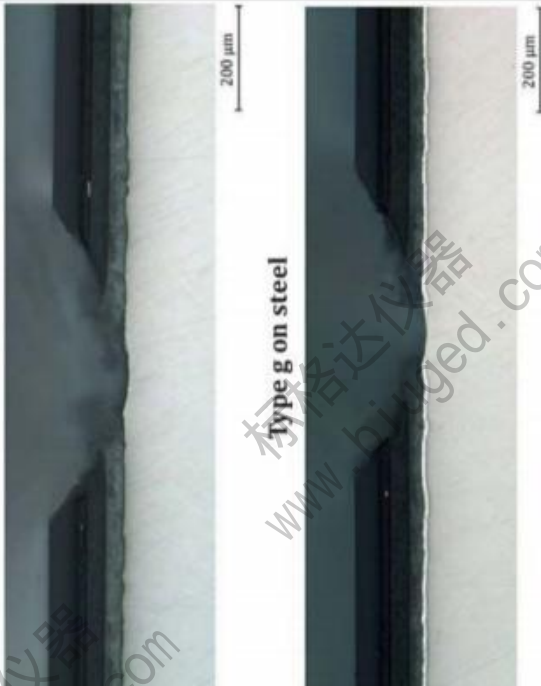

Tool <sup>a</sup>	Country	Material	Possible scribe width mm	Remarks	Cross section examples <sup>b</sup>
  j) Van Laar <sup>®</sup> k) E-6 <sup>®</sup>	Germany    USA	Tungsten carbide    Carbon steel	0,2 to 0,3		
Milling machines					
 l) S22A <sup>®</sup> (Electric rotary tool)	Japan	Diamond with carbon steel		Not dependent from coating thickness. Scribing depth is adjustable. It is recommended not to scribe too deep in the metallic substrate.	

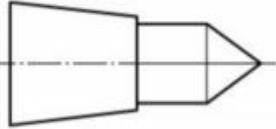
Table A.1 (continued)

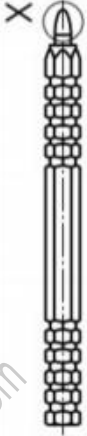
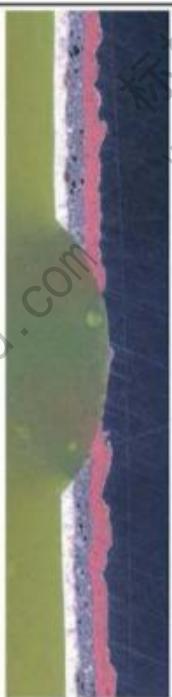
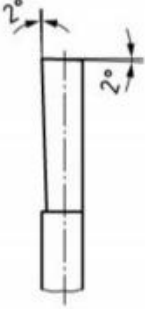

Tools <sup>a</sup>	Country	Material	Possible scribe width mm	Remarks	Cross section examples <sup>b</sup>
 <p>Key 1 coating 2 substrate a cutter thickness</p> <p>m) Disc milling cutter</p>	Germany	Hardened carbon steel	1,0 to 2,0	Not dependent from coating thickness. Scribing depth is adjustable. It is recommended not to scribe too deep in the metallic substrate.	
 <p>n) End mill</p> <p>version 1 version 2 version 3</p>	Germany	Hardened carbon steel	0,5 to 2,0	Not dependent from coating thickness. Scribing depth is adjustable. It is recommended not to scribe too deep in the metallic substrate.	

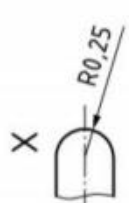
Table A.1 (continued)

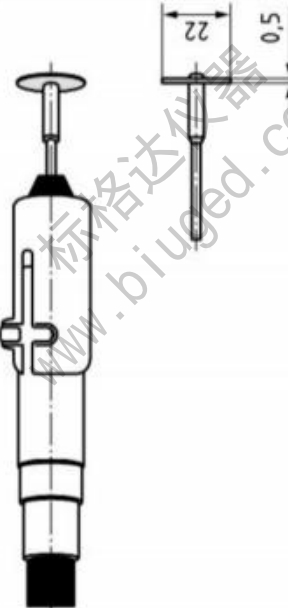
Tool <sup>a</sup>	Country	Material	Possible scribe width mm	Remarks	Cross section examples <sup>b</sup>
<p><sup>a</sup> These are examples of suitable products available commercially. This information is given for the convenience of users of this document and does not constitute an endorsement by ISO of these products.</p>					
<p><sup>b</sup> These are examples where partially given scribe widths are dependent on the used coating, cutting depths and surfaces of the examples.</p>					

## Annex B (informative)

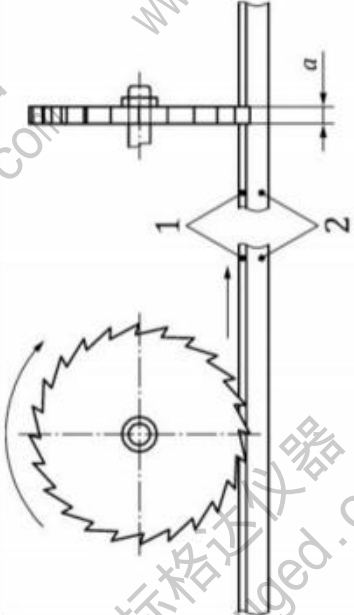
### Examples of possible different results in one corrosion test when using different scribing tools

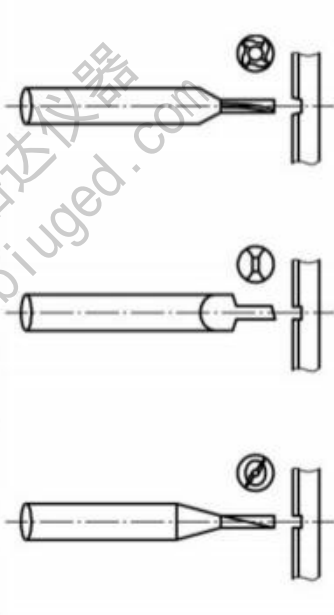
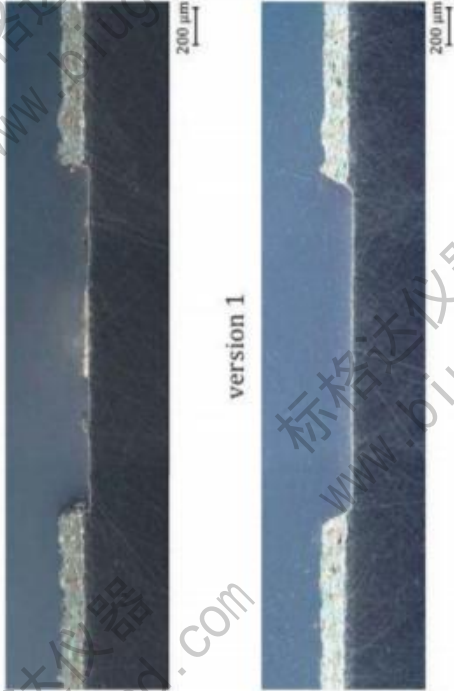
Repeatedly, different scribing patterns respectively the introduction of different scribe marks in the same tests form the basis of discussions among test parties. Some customer specifications or other test specifications contain information as to which scribing tools are meant to be used. However, there are also a lot of specifications in which the type of damage caused by the scribing tool is not described. Therefore, most testing laboratories operate to the best of their knowledge.

An investigation shows how different scribing tools applied to one and the same specimen, tested in the same test, can behave differently.

It has to be taken into account that this is only one example of a coating system. A conventional automotive coating with chemical pretreatment, cathodic electro-deposition coating and a composition of primer, base coat and clear coat, as it is currently applied in the industry, was used.

The tests were carried out on standard substrates for the automotive industry: cold rolled steel (ref.: CRS), electrogalvanized steel (ref.: ZE) and hot-dip galvanized steel (ref.: Z). Examples of original panels of the three variants Z, CRS and ZE are shown in [Figures B.3 to B.5](#). As shown in [Figure B.2](#), a considerable influence can be seen in this test, especially when galvanized substrates are used. The test was carried out according to ISO 11997-1, cycle B, with a duration of 10 weeks. The scribing tools used in this test are shown in [Figure B.1](#). Examples of confocal microscope pictures (topographies) of the scribing tools f, i, g and j are shown in [Figure B.6](#).

**ATTENTION — Results can be different by using the same different scribing tools in a different corrosion test.**

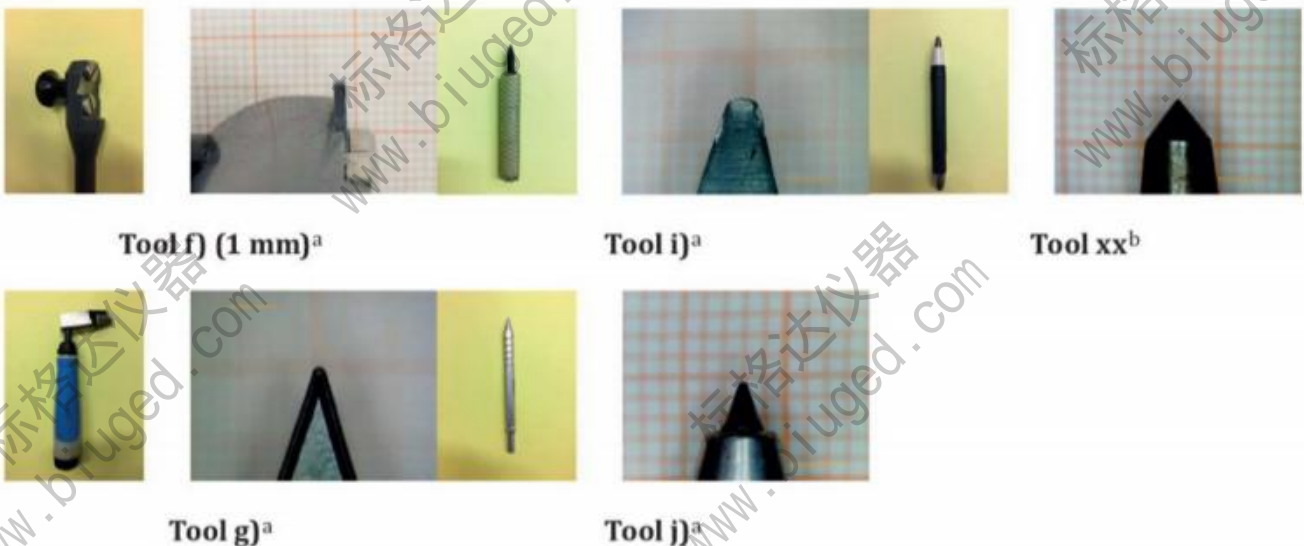

#### Key

- <sup>a</sup> Tools in accordance with [Table A.1](#).
- <sup>b</sup> Common (in-house) tool with hardened tip.

**Figure B.1 — Scribing tools used for the test**

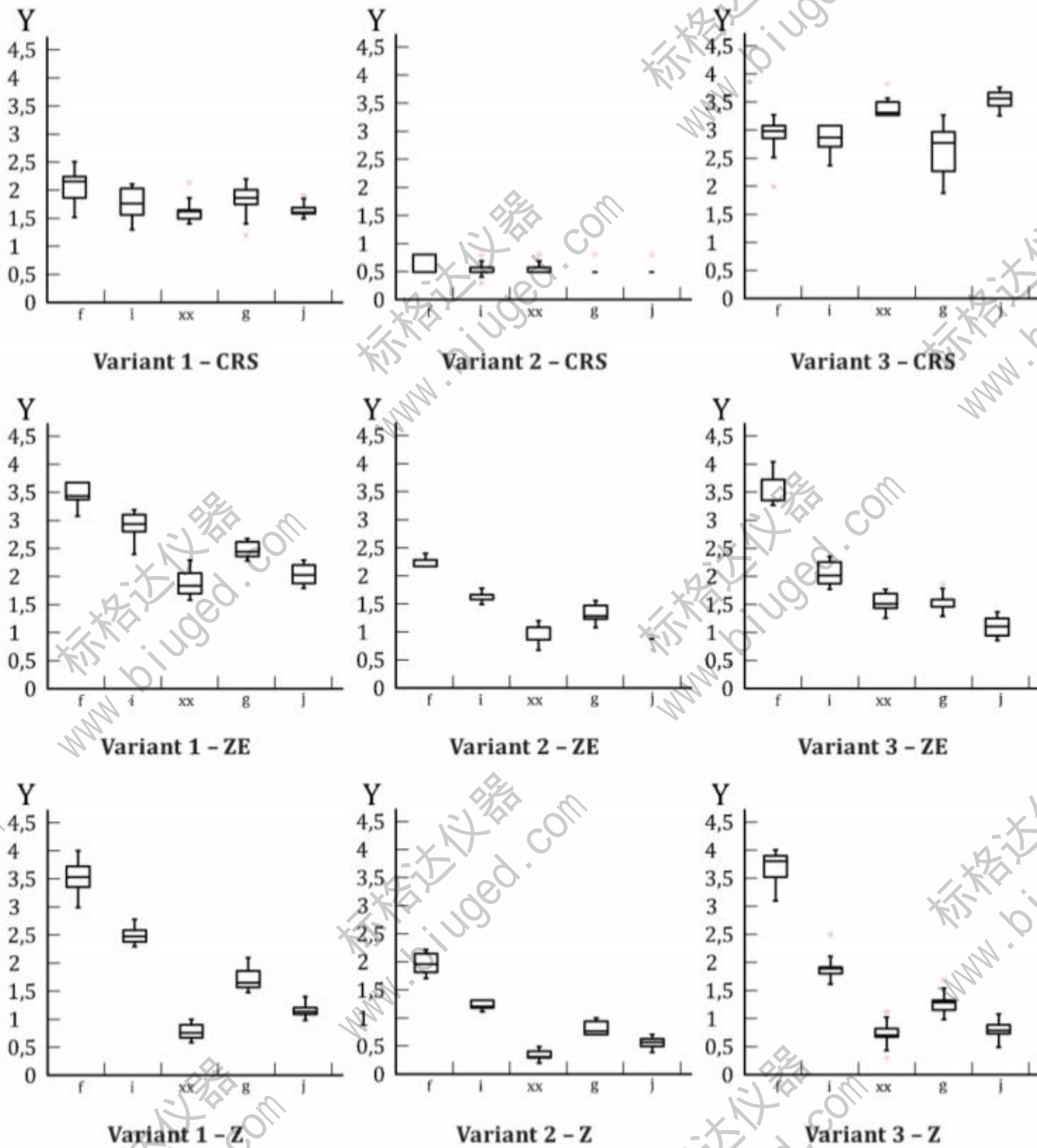

**Key**  
 CRS Coiled Rolled Steel  
 ZE electrogalvanized steel, automotive quality  
 Z hot dip galvanized steel, automotive quality  
 Y delamination around the scribe, in millimetres

• maximum outlier  
 • minimum outlier

**Figure B.2 — Delamination d in accordance with ISO 4628-8, different scribing tools after 10 weeks ISO 11997-1, cycle B (boxplot of 8 test panels, 3 different variants)**



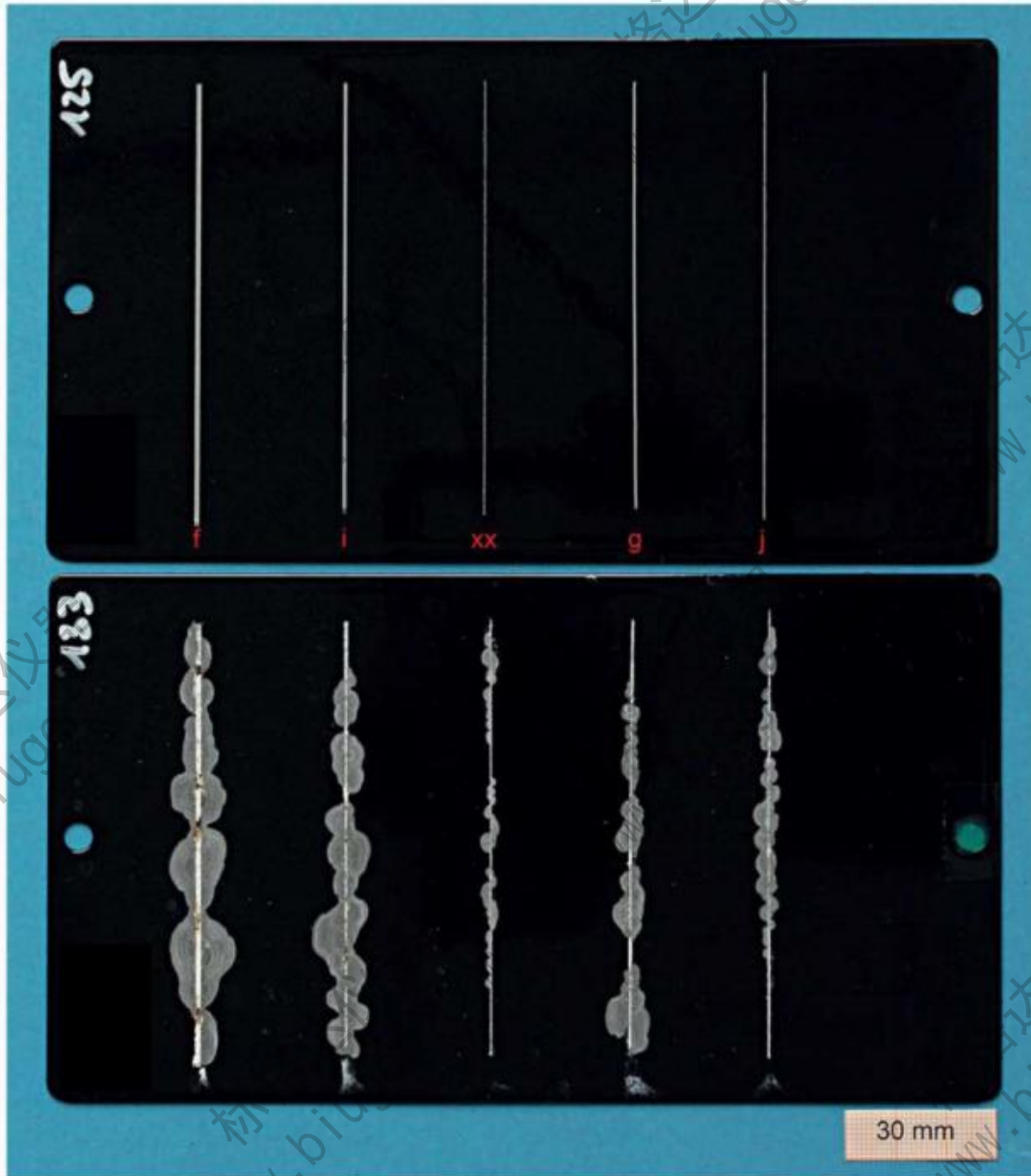

Figure B.3 — Example of an original panel of one the variants from Figure B.2 — substrate “Z” (above before test/below after 10 weeks testing time)

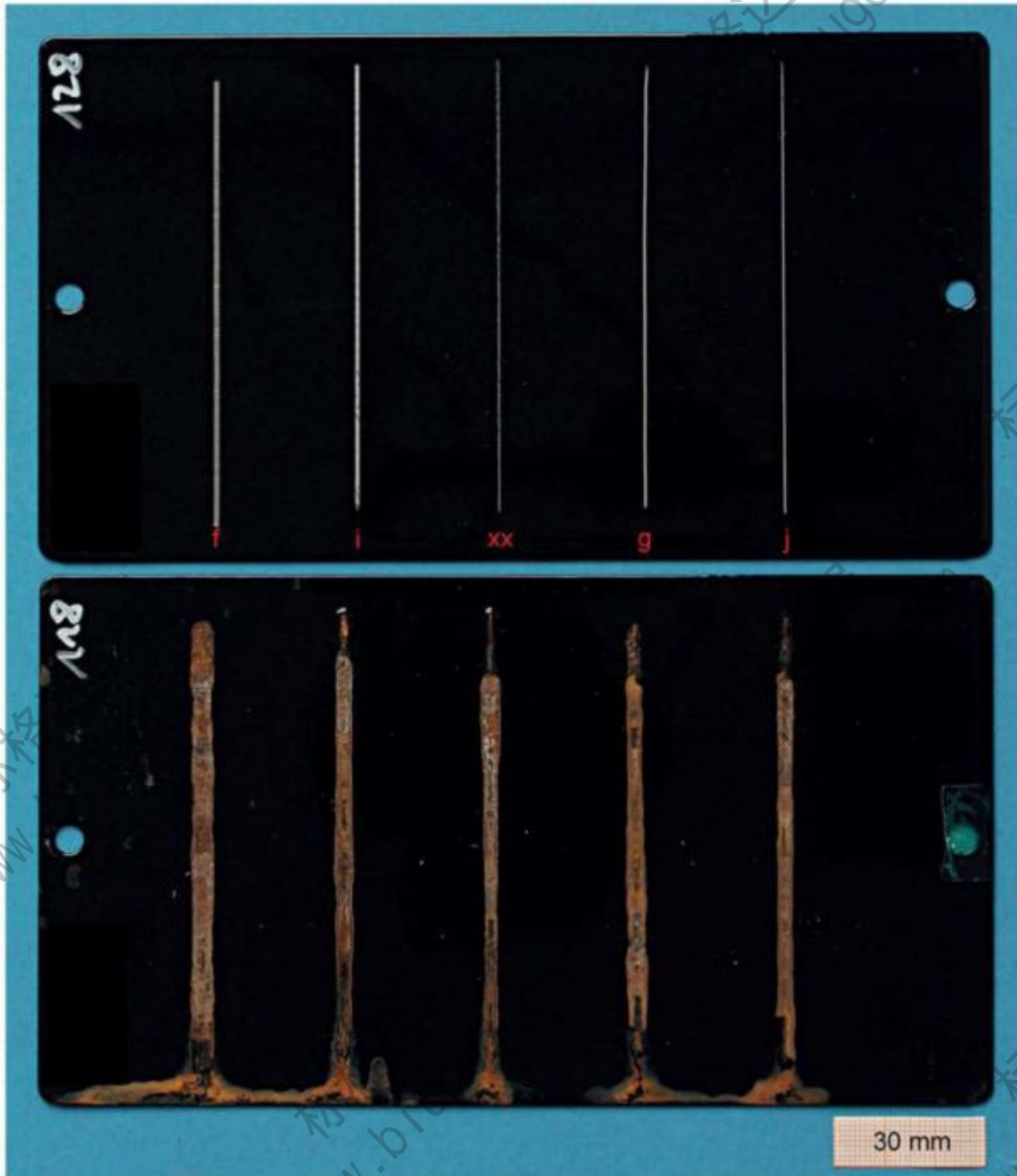

Figure B.4 — Example of an original panel of one the variants from Figure B.2 — substrate “CRS” (above before test/below after 10 weeks testing time)

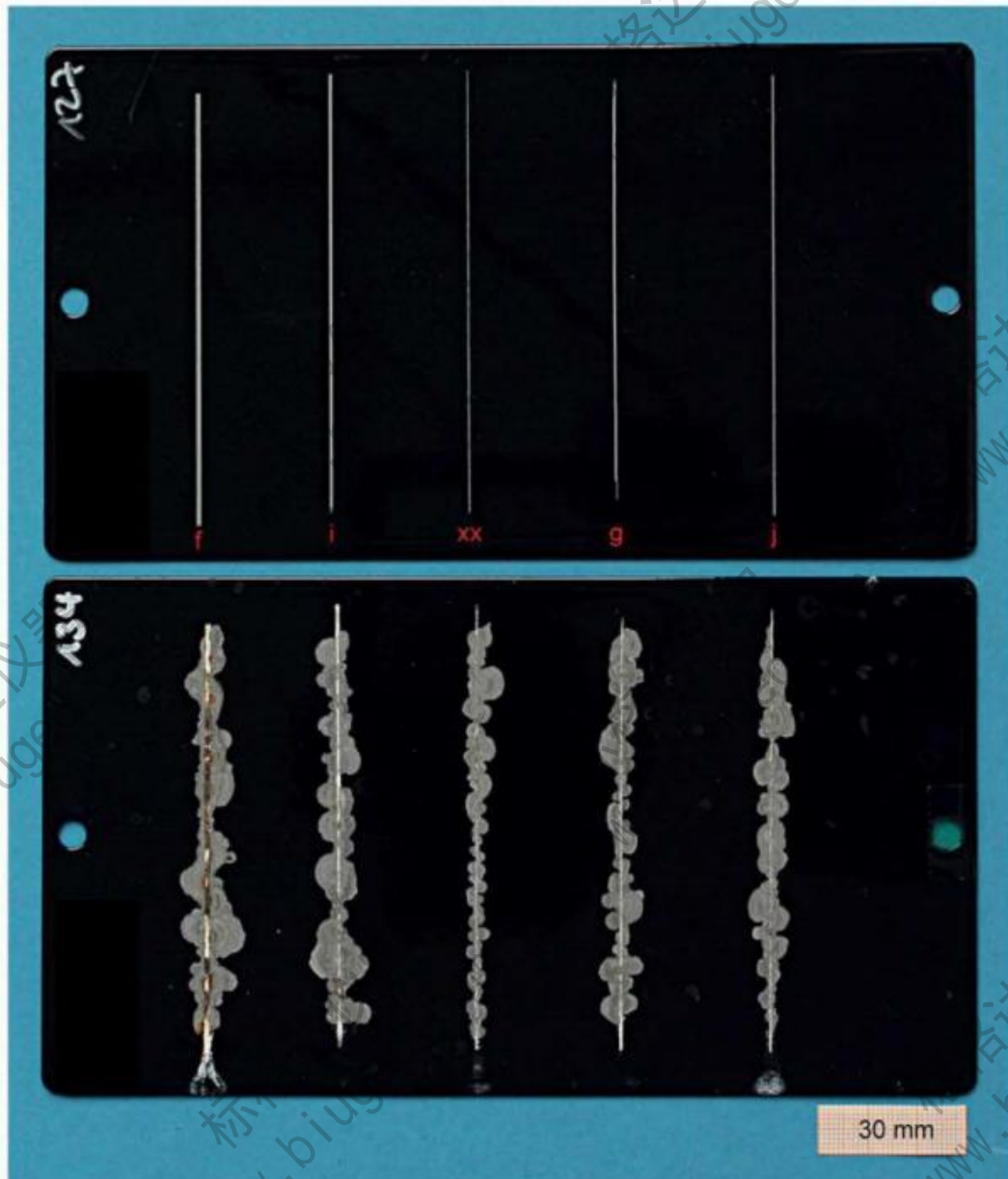

Figure B.5 — Example of an original panel of one the variants from Figure B.2 — substrate “ZE” (above before test/below after 10 weeks testing time)

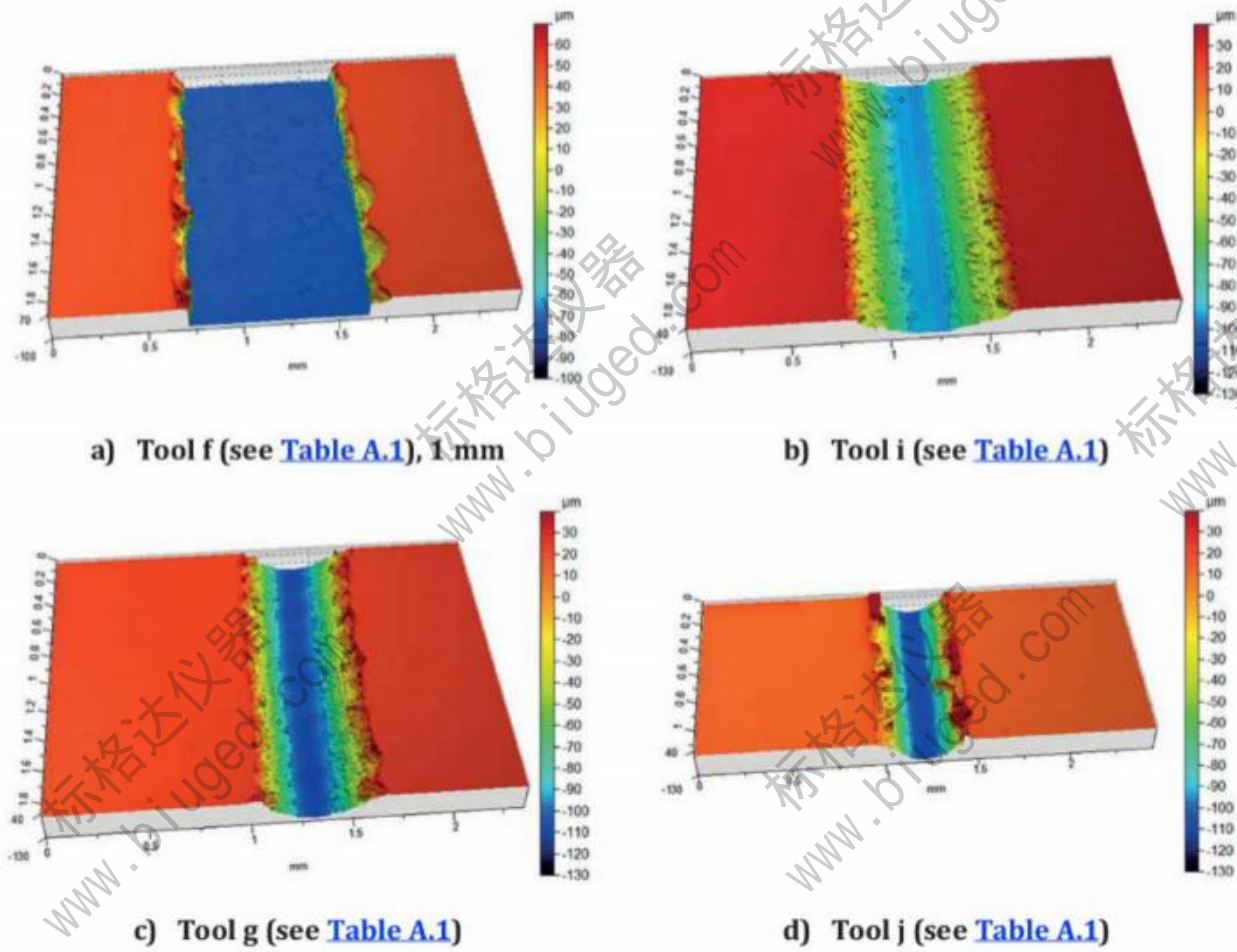

Figure B.6 — Example of confocal microscope pictures (topographies) of single scribing tools (from Table A.1)

## Bibliography

- [1] ISO 4623-1, *Paints and varnishes — Determination of resistance to filiform corrosion — Part 1: Steel substrates*
- [2] ISO 4623-2, *Paints and varnishes — Determination of resistance to filiform corrosion — Part 2: Aluminium substrates*
- [3] ISO 4628-8, *Paints and varnishes — Evaluation of degradation of coatings — Designation of quantity and size of defects, and of intensity of uniform changes in appearance — Part 8: Assessment of degree of delamination and corrosion around a scribe or other artificial defect*
- [4] ISO 9227, *Corrosion tests in artificial atmospheres — Salt spray tests*
- [5] ISO 11997-1, *Paints and varnishes — Determination of resistance to cyclic corrosion conditions — Part 1: Wet (salt fog)/dry/humid*
- [6] ISO 12944-6, *Paints and varnishes — Corrosion protection of steel structures by protective paint systems — Part 6: Laboratory performance test methods*
- [7] ISO 12944-9, *Paints and varnishes — Corrosion protection of steel structures by protective paint systems — Part 9: Protective paint systems and laboratory performance test methods for offshore and related structures*

标格达仪器  
www.biuged.com

标格达仪器  
www.biuged.com

标格达仪器  
www.biuged.com

标格达仪器  
www.biuged.com

标格达仪器  
www.biuged.com

标格达仪器  
www.biuged.com

标格达仪器  
www.biuged.com

标格达仪器  
www.biuged.com

标格达仪器  
www.biuged.com

标格达仪器  
www.biuged.com

标格达仪器  
www.biuged.com

标格达仪器  
www.biuged.com

标格达仪器  
www.biuged.com

标格达仪器  
www.biuged.com

标格达仪器  
www.biuged.com

This page has been left intentionally blank.

标格达仪器  
www.biuged.com

标格达仪器  
www.biuged.com

标格达仪器  
www.biuged.com

标格达仪器  
www.biuged.com

标格达仪器  
www.biuged.com