

INTERNATIONAL
STANDARD

ISO
20566

Third edition
2020-05

**Paints and varnishes —
Determination of the scratch
resistance of a coating system using a
laboratory-scale car-wash**

Peintures et vernis — Détermination de la résistance à la rayure d'un système de peinture sur un poste de lavage automobile de laboratoire



Reference number
ISO 20566:2020(E)

© ISO 2020



COPYRIGHT PROTECTED DOCUMENT

© ISO 2020

All rights reserved. Unless otherwise specified, or required in the context of its implementation, no part of this publication may be reproduced or utilized otherwise in any form or by any means, electronic or mechanical, including photocopying, or posting on the internet or an intranet, without prior written permission. Permission can be requested from either ISO at the address below or ISO's member body in the country of the requester.

ISO copyright office
CP 401 • Ch. de Blandonnet 8
CH-1214 Vernier, Geneva
Phone: +41 22 749 01 11
Fax: +41 22 749 09 47
Email: copyright@iso.org
Website: www.iso.org

Published in Switzerland

Contents

Page

Foreword	iv
Introduction	v
1 Scope	1
2 Normative references	1
3 Terms and definitions	1
4 Apparatus	2
5 Washing suspension	3
6 Sampling	4
7 Test panels	4
8 Procedure	4
9 Evaluation	5
10 Precision	5
10.1 Repeatability limit r	5
10.2 Reproducibility limit, R	5
11 Test report	5
Annex A (normative) Verification and calibration of the washing equipment	7

Foreword

ISO (the International Organization for Standardization) is a worldwide federation of national standards bodies (ISO member bodies). The work of preparing International Standards is normally carried out through ISO technical committees. Each member body interested in a subject for which a technical committee has been established has the right to be represented on that committee. International organizations, governmental and non-governmental, in liaison with ISO, also take part in the work. ISO collaborates closely with the International Electrotechnical Commission (IEC) on all matters of electrotechnical standardization.

The procedures used to develop this document and those intended for its further maintenance are described in the ISO/IEC Directives, Part 1. In particular, the different approval criteria needed for the different types of ISO documents should be noted. This document was drafted in accordance with the editorial rules of the ISO/IEC Directives, Part 2 (see www.iso.org/directives).

Attention is drawn to the possibility that some of the elements of this document may be the subject of patent rights. ISO shall not be held responsible for identifying any or all such patent rights. Details of any patent rights identified during the development of the document will be in the Introduction and/or on the ISO list of patent declarations received (see www.iso.org/patents).

Any trade name used in this document is information given for the convenience of users and does not constitute an endorsement.

For an explanation of the voluntary nature of standards, the meaning of ISO specific terms and expressions related to conformity assessment, as well as information about ISO's adherence to the World Trade Organization (WTO) principles in the Technical Barriers to Trade (TBT), see www.iso.org/iso/foreword.html.

This document was prepared by Technical Committee ISO/TC 35, *Paints and varnishes*, Subcommittee SC 9, *General test methods for paints and varnishes*, in collaboration with the European Committee for Standardization (CEN) Technical Committee CEN/TC 139, *Paints and varnishes*, in accordance with the Agreement on technical cooperation between ISO and CEN (Vienna Agreement).

This third edition cancels and replaces the second edition (ISO 20566:2013), which has been technically revised. The main changes compared to the previous edition are as follows:

- the term “control panel” has been changed to “reference panel”;
- the requirement for the temperature of the washing suspension has been deleted;
- verification using a plastics panel has been added to [Annex A](#);
- the text has been editorially revised and the normative references have been updated.

Any feedback or questions on this document should be directed to the user's national standards body. A complete listing of these bodies can be found at www.iso.org/members.html.

Introduction

With this test procedure, it is important to note that the test results will not, over time, remain constant, as a result of changes to the brush material. As the brush ages, the test will become more severe. As a result, the test procedure is suitable only for comparative tests carried out at any one time and using relatively short runs. Readings obtained using equipment which has accumulated different total numbers of operating hours are not comparable with each other.

.com

1 2 3 4 5 6 7 8 9 10 11 12 13 14 15 16 17 18 19 20 21 22 23 24 25 26 27 28 29 30 31 32 33 34 35 36 37 38 39 40 41 42 43 44 45 46 47 48 49 50 51 52 53 54 55 56 57 58 59 60 61 62 63 64 65 66 67 68 69 70 71 72 73 74 75 76 77 78 79 80 81 82 83 84 85 86 87 88 89 90 91 92 93 94 95 96 97 98 99 100

标格达仪器
www.biuged.com

标格达仪器
www.biuged.com

标格达仪器
www.biuged.com

标格达仪器
www.biuged.com

标格达仪器
www.biuged.com

标格达仪器
www.biuged.com

标格达仪器
www.biuged.com

标格达仪器
www.biuged.com

标格达仪器
www.biuged.com

标格达仪器
www.biuged.com

Paints and varnishes — Determination of the scratch resistance of a coating system using a laboratory-scale car-wash

1 Scope

This document specifies a test procedure for assessing the scratch resistance of organic paint coatings, in particular paint coatings used in the automotive industry (i.e. for assessing their car-wash resistance). Machine-based washing is simulated in the laboratory environment using a rotating brush and synthetic dirt. The test conditions have been designed to be as close as possible to the real conditions in a car-wash. If the test parameters are suitably chosen, the method can also be used for testing protective plastics films and plastics components.

2 Normative references

The following documents are referred to in the text in such a way that some or all of their content constitutes requirements of this document. For dated references, only the edition cited applies. For undated references, the latest edition of the referenced document (including any amendments) applies.

ISO 1513, *Paints and varnishes — Examination and preparation of test samples*

ISO 2813, *Paints and varnishes — Determination of gloss value at 20°, 60° and 85°*

ISO 4618, *Paints and varnishes — Terms and definitions*

ISO 4628-1, *Paints and varnishes — Evaluation of degradation of coatings — Designation of quantity and size of defects, and of intensity of uniform changes in appearance — Part 1: General introduction and designation system*

ISO 13076, *Paints and varnishes — Lighting and procedure for visual assessments of coatings*

ISO 13803, *Paints and varnishes — Determination of haze on paint films at 20°*

ISO 15528, *Paints, varnishes and raw materials for paints and varnishes — Sampling*

ISO 18314-1, *Analytical colorimetry — Part 1: Practical colour measurement*

3 Terms and definitions

For the purposes of this document, the terms and definitions given in ISO 4618 and the following apply.

ISO and IEC maintain terminological databases for use in standardization at the following addresses:

— ISO Online browsing platform: available at <https://www.iso.org/obp>

— IEC Electropedia: available at <http://www.electropedia.org/>

3.1

double pass

single back-and-forward movement of the test panel holder

3.2

test area

area which is evaluated

3.3

reflow effect

ability of the coating surface to revert to its original appearance after damage such as scratching

4 Apparatus

The apparatus¹⁾ shall comprise at least the following individual components:

4.1 Washing brush:

Diameter	(1 000 ± 40) mm
Width	min. 300 mm, typically 400 mm
Material	polyethylene
Profile	x-shaped, spliced
Bristle thickness	(0,8 ± 0,2) mm
Bristle length	(440 ± 20) mm visible
Penetration depth	(100 ± 20) mm (see Figure 1)
Speed of brush rotation	(127 ± 5) min ⁻¹ , in the direction opposite to the direction of travel of the test panel holder

The replacement of washing brushes is decided by testing a reference panel. The reference panel material shall be chosen to reflect changes in the washing brush, so that it is possible to differentiate between a new and a used brush.

The apparatus shall be calibrated as described in [Annex A](#) using a reference panel, either the plastics panel described in [A.1.2](#) or a panel coated with a black non-metallic paint and a clear coat on top as described in [A.1.3](#).

4.2 Spray nozzles, made of stainless steel:

Spread of jet	65°
Rate of flow of washing suspension	(2,2 ± 0,2) l/min at (300 ± 50) kPa

The two nozzles shall spray alternately, against the direction of travel of the test panel holder. They shall produce the specified spray pattern (see [Annex A](#)).

1) Information on procuring the test apparatus is available at: DIN Deutsches Institut für Normung e.V., NAB, Burggrafenstrasse 6, 10787 Berlin, Germany.

4.3 Test panel holder:

Feed speed (5,0 ± 0,2) m/min

Pattern of movement If the brush is rotating clockwise, the right nozzle is spraying and the test panel holder travels from left to right (and vice versa) — see [Figure 1](#).

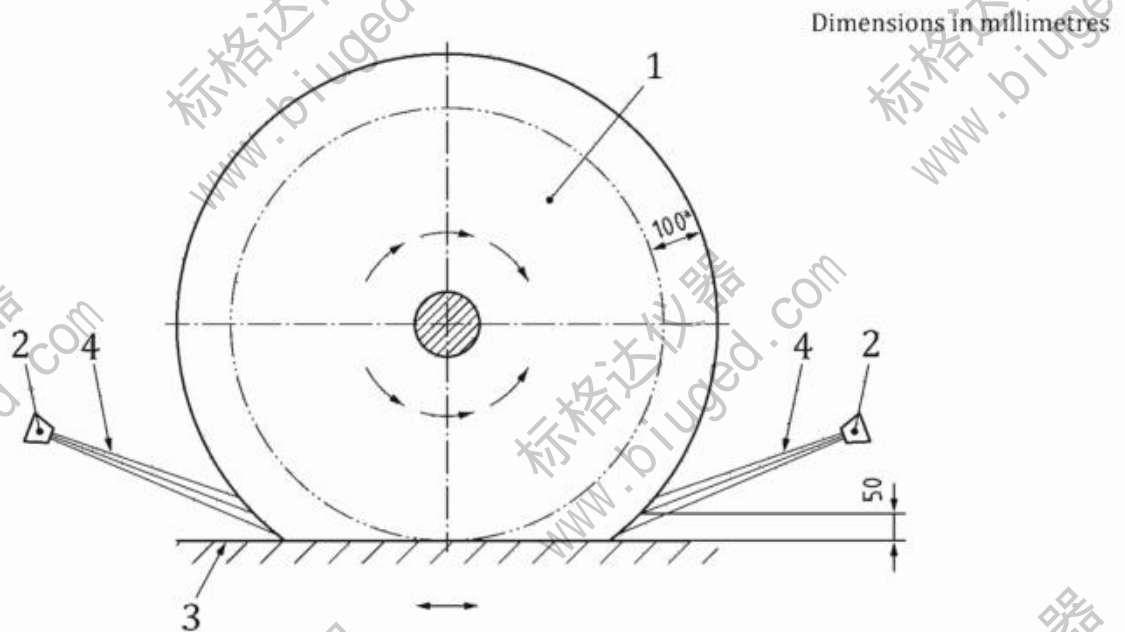

Key

- 1 washing brush
- 2 spray nozzle
- 3 test panel holder
- 4 spray jet (centreline of jet strikes brush directly, 50 mm above test panel holder)
- a Penetration depth.

Figure 1 — Pattern of movement of washing brush and spray nozzles with respect to test panel holder

4.4 Container, suitable for holding the washing suspension during the test.

4.5 Glossmeter in accordance with ISO 2813.

5 Washing suspension

Prepare a suspension consisting of (1,50 ± 0,05) g of silica powder (silica micro-powder having a mean particle size $d_{50\%}$ of 24 μm²⁾) per litre of tap water in a suitable container, mixing it by stirring vigorously.

2) Information on procuring the silica powder is available from: DIN Deutsches Institut für Normung e.V., NAB, Burggrafenstrasse 6, 10787 Berlin, Germany.

The suspension shall be stirred continuously before and during the test in such a way that the silica powder does not settle on the bottom of the container as this would result in variations in the concentration.

The suspension may be reused once the test equipment has come to a standstill. However, it is essential that the suspension be stirred thoroughly again before being reused.

Before standstill of more than 2 days, the container should be emptied completely to avoid microbiological growth.

6 Sampling

Take a representative sample of the product to be tested, as specified in ISO 15528.

Examine and prepare each sample for testing, as specified in ISO 1513.

If testing a clearcoat, the basecoat shall be single shade of black.

7 Test panels

Test panels shall be flat and free of deformations. The substrate and size shall be as agreed between the interested parties. The thickness of the test panels should preferably be between 0,5 mm and 5 mm. With other thicknesses, the depth of penetration into the washing brush and the angle of approach of the brush shall be adjusted by setting the test-panel holder to the correct height.

The spraying, drying/hardening and stoving parameters, and the ageing and conditioning before the test, shall be as agreed between the interested parties.

NOTE If test panels thicker than 5 mm or test specimens other than flat test panels are used, the test results can spread widely, because the bristles touch the surface of the sample differently, so they wear differently.

8 Procedure

Carry out the test at room temperature.

The optimum test area shall be identified for each test apparatus, especially after changing the brush, by a control test, as follows. Using a reference panel (see [Annex A](#)), determine the area on the test panels in which the difference in gloss compared to the most scratched area is not more than 15 gloss units. Do not evaluate the area at least 5 cm wide at each end of the test panels or the areas at least 3 cm wide along the edges of the panels, parallel to the direction of travel of the test panels.

Before carrying out a test, perform a preliminary run without any test panels, carrying out 10 washing operations (10 double passes), to distribute the washing suspension evenly in the apparatus.

Make sure that the thickness of the test panels is the same over the whole test area.

Prior to testing, examine the coated test panels visually in accordance with ISO 13076 and determine the initial value of the parameter to be measured, e.g. gloss in accordance with ISO 2813, haze in accordance with ISO 13803 or colour in accordance with ISO 18314-1.

Set the required pressure and verify it.

Position the test panels on the test panel holder and carry out 10 washing operations (10 double passes) using the back-and-forth pattern of movement shown in [Figure 1](#).

Rinse the washed test panels with cold water then clean them with a suitable solvent, e.g. white spirit, using soft, non-scratching paper tissues and wiping in the direction of the scratches. Finally, leave for 10 min to dry off. This process is designed to remove all residues of silica powder, and any abraded material from the brush.

Special boiling point spirit 60/95 (CAS-No 64742-49-0) has been found most suitable for cleaning painted surfaces to remove abrasion marks produced by the brush. Generally, preliminary tests for chemical resistance are necessary, however.

Verify the test apparatus regularly using a reference panel (see [Annex A](#)).

If the test equipment will not be used for some time (after completion of a test series) it should be rinsed thoroughly with tap water to avoid sedimentation.

9 Evaluation

Within 2 h of drying, examine the test panels as follows:

- visually, as described in ISO 13076, for any change except in gloss, haze and colour, designating the change in accordance with ISO 4628-1;
- for gloss, in accordance with ISO 2813;
- for haze, in accordance with ISO 13803;
- for colour, in accordance with ISO 18314-1.

Measure the gloss, haze or colour of the test panels across the direction of scratching. Only make measurements in the test area (see [3.2](#)).

Calculate the mean of three readings across the entire area of damage on the test panels. From these values, calculate the difference in gloss, haze or colour, or the percentage change in gloss or haze and the difference in colour (ΔE), relative to the initial reading. If agreed, an optical imaging analysis may be carried out.

Depending on the paint system used, the reflow effect, i.e. the self-repairing effect, might be more or less evident. The conditions of the evaluation after washing shall therefore be agreed between the interested parties.

10 Precision

10.1 Repeatability limit, r

The repeatability limit, r , is the value below which the absolute difference between two single test results, each the mean of duplicates, can be expected to lie when this method is used under repeatability conditions, i.e. when the test results are obtained on identical material by one operator in one laboratory within a short interval of time using the standardized test method. For this method, in the case of gloss measurement (reflectometer readings), r is 14 units, with a 95 % probability.

10.2 Reproducibility limit, R

The reproducibility limit, R , is the value below which the absolute difference between two test results, each the mean of duplicates, can be expected to lie when this test method is used under reproducibility conditions, i.e. when the test results are obtained on identical material by operators in different laboratories using the standardized test method. For this method, in the case of gloss measurement (reflectometer readings), R is 20 units, with a 95 % probability.

11 Test report

The test report shall contain at least the following information:

- a) all information necessary for the identification of the sample tested;

- b) a reference to this document (ISO 20566:2020);
- c) details of the procedure, including
 - 1) the type of test panel used and its dimensions,
 - 2) the spraying, drying/hardening and stoving parameters, and any ageing and conditioning before the test,
 - 3) the temperature at which the test was carried out,
 - 4) the test result obtained with the reference panel,
 - 5) the total running time (age) of the washing brush, and
 - 6) any specific agreements not otherwise mentioned in 1) to 5);
- d) the type of silica powder used for the washing suspension, including the mean particle size;
- e) the results of the test, including the results of the individual measurements and their mean, calculated as specified in [Clause 9](#);
- f) any deviations from the procedure specified;
- g) any unusual features (anomalies) observed during the test;
- h) the date of the test;
- i) the name of the person who carried out the test.

Annex A (normative)

Verification and calibration of the washing equipment

A.1 Verification of the washing equipment with a reference panel

A.1.1 General

The condition of the washing equipment shall be verified regularly using suitable reference panels.

As a result of their nature, the polyethylene brushes are subject to continuous change during use, i.e. test results will not, over time, remain constant. The scratching effect which they produce becomes more pronounced after long periods of use. Reference panels are used to monitor the state of the brush so that, when necessary, the brush can be replaced.

The reference panel material shall be chosen to reflect any changes in the washing brush, so that it is possible to differentiate between a new and used brush.

A.1.2 Plastics panel

A.1.2.1 Material and size

Polycarbonate MVR (300 °C/1,2 kg) 19 cm³/10 min, Standard black, minimum size 100 mm × 150 mm.

A.1.2.2 Procedure

Carry out the test as described in [Clause 8](#), using the plastics panel. Measure the gloss at 60° in accordance with ISO 2813 of three measuring points on the reference panel before and after the test.

The washing brush shall be replaced by a new brush if the gloss of the reference panel changes by 20 % compared with a new brush.

A.1.3 Coated panel

A.1.3.1 Material and size

Panel coated with a black non-metallic paint and a clear coat on top, minimum size 100 mm × 150 mm.

A.1.3.2 Procedure

Carry out the test as described in [Clause 8](#), using the coated panel. Measure the gloss at 20° in accordance with ISO 2813 of three measuring points on the reference panel before and after the test.

The gloss shall be >80 GU. The washing brush shall be replaced by a new brush if the gloss of the reference panel changes by more than 6 GU compared with a new brush.

A.2 Calibration of the washing equipment

A.2.1 Apparatus

Ordinary laboratory equipment, together with the following:

A.2.1.1 Sheet of cardboard, measuring approximately 500 mm × 130 mm.

A.2.1.2 Stopwatch.

A.2.2 Procedure

Set up the equipment as shown in [Figure A.1](#), with the calibration material [e.g. a sheet of cardboard ([A.2.1.1](#))] in a suitable holder in the path of the spray jet. Fill the container with washing suspension (see [Clause 5](#)). Determine the flow rate of the washing suspension by measurement of the volume or by weighing, and adjust, if necessary, to $(2,2 \pm 0,2)$ l/min by altering the pressure. Start the spraying process and allow it to continue for approximately 60 s. Immediately after spraying, mark the outline of the wetted area. Check the spray pattern of both nozzles in this way (see [Figure A.2](#)).

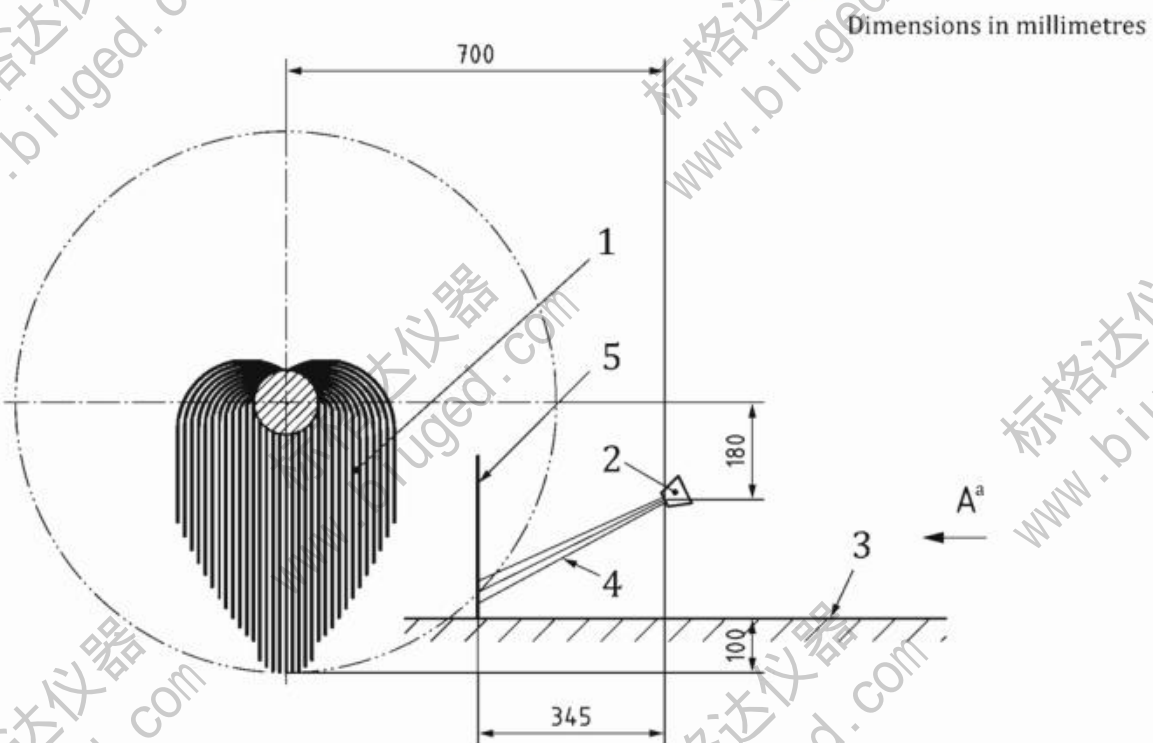

Key

- 1 brush
- 2 spray nozzle
- 3 test panel holder
- 4 spray jet
- 5 holder with the calibration material, e.g. a sheet of cardboard

^a View A (see [Figure A.2](#)).

Figure A.1 — Calibration arrangement

Dimensions in millimetres

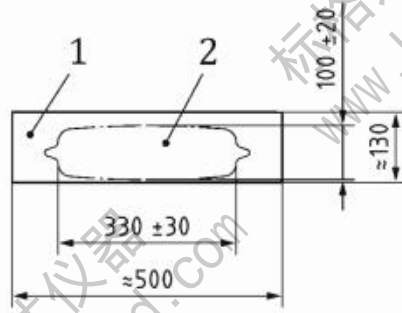
**Key**

- 1 calibration material, e.g. a sheet of cardboard
- 2 spray pattern

Figure A.2 — Example of the view, including dimensions for this example

标格达仪器
www.biuged.com

标格达仪器
www.biuged.com

标格达仪器
www.biuged.com

标格达仪器
www.biuged.com

标格达仪器
www.biuged.com

标格达仪器
www.biuged.com

标格达仪器
www.biuged.com

标格达仪器
www.biuged.com

标格达仪器
www.biuged.com

标格达仪器
www.biuged.com

标格达仪器
www.biuged.com

标格达仪器
www.biuged.com

标格达仪器
www.biuged.com

标格达仪器
www.biuged.com

标格达仪器
www.biuged.com

This page has been left intentionally blank.

标格达仪器
www.biuged.com

标格达仪器
www.biuged.com

标格达仪器
www.biuged.com

标格达仪器
www.biuged.com

标格达仪器
www.biuged.com