



Designation: B905 – 00 (Reapproved 2016)

## Standard Test Methods for Assessing the Adhesion of Metallic and Inorganic Coatings by the Mechanized Tape Test<sup>1</sup>

This standard is issued under the fixed designation B905; the number immediately following the designation indicates the year of original adoption or, in the case of revision, the year of last revision. A number in parentheses indicates the year of last reapproval. A superscript epsilon ( $\epsilon$ ) indicates an editorial change since the last revision or reapproval.

### 1. Scope

1.1 These test methods describe procedures for assessing the adhesion of metallic and inorganic coatings and other thin films to metallic and nonmetallic substrates. Assessment is made by applying pressure-sensitive tape to a coated surface and then utilizing a mechanical device to remove the tape at a regulated, uniform rate and constant angle while simultaneously recording the removal force.

1.2 Four methods are described. Methods A1 and A2 are intended primarily for use on parts. Methods B1 and B2 are intended primarily for use in laboratory evaluations. Methods B1 and B2 are not recommended for testing coatings and films on polymer substrates.

1.3 These test methods may be used to establish whether the adhesion of a coating to a substrate is within a required range (between a quantified low and a quantified high level). Determination of actual adhesive forces requires more sophisticated methods of measurement. In multilayer systems adhesion failure may occur between intermediate coating layers so that the adhesion of the total coating system to the substrate may not necessarily be determined.

1.4 The values stated in SI units are to be regarded as standard. No other units of measurement are included in this standard.

1.5 *This standard does not purport to address all of the safety concerns, if any, associated with its use. It is the responsibility of the user of this standard to establish appropriate safety and health practices and determine the applicability of regulatory limitations prior to use.*

### 2. Referenced Documents

#### 2.1 ASTM Standards:<sup>2</sup>

- B183 Practice for Preparation of Low-Carbon Steel for Electroplating
- B242 Guide for Preparation of High-Carbon Steel for Electroplating
- B252 Guide for Preparation of Zinc Alloy Die Castings for Electroplating and Conversion Coatings
- B253 Guide for Preparation of Aluminum Alloys for Electroplating
- B254 Practice for Preparation of and Electroplating on Stainless Steel
- B281 Practice for Preparation of Copper and Copper-Base Alloys for Electroplating and Conversion Coatings
- B320 Practice for Preparation of Iron Castings for Electroplating
- B343 Practice for Preparation of Nickel for Electroplating with Nickel
- B480 Guide for Preparation of Magnesium and Magnesium Alloys for Electroplating
- B481 Practice for Preparation of Titanium and Titanium Alloys for Electroplating
- B482 Practice for Preparation of Tungsten and Tungsten Alloys for Electroplating
- B537 Practice for Rating of Electroplated Panels Subjected to Atmospheric Exposure
- B538 Method of FACT (Ford Anodized Aluminum Corrosion Test) (Withdrawn 1986)<sup>3</sup>
- B629 Practice for Preparation of Molybdenum and Molybdenum Alloys for Electroplating
- B630 Practice for Preparation of Chromium for Electroplating with Chromium
- B727 Practice for Preparation of Plastics Materials for Electroplating
- D1730 Practices for Preparation of Aluminum and Aluminum-Alloy Surfaces for Painting

<sup>1</sup> These test methods are under the jurisdiction of ASTM Committee B08 on Metallic and Inorganic Coatings and are the direct responsibility of Subcommittee B08.10 on Test Methods.

Current edition approved Nov. 1, 2016. Published November 2016. Originally approved in 2000. Last previous edition approved in 2010 as B905 – 00 (2010). DOI: 10.1520/B0905-00R16.

<sup>2</sup> For referenced ASTM standards, visit the ASTM website, [www.astm.org](http://www.astm.org), or contact ASTM Customer Service at [service@astm.org](mailto:service@astm.org). For *Annual Book of ASTM Standards* volume information, refer to the standard's Document Summary page on the ASTM website.

<sup>3</sup> The last approved version of this historical standard is referenced on [www.astm.org](http://www.astm.org).



- D1731 Practices for Preparation of Hot-Dip Aluminum Surfaces for Painting
- D1732 Practices for Preparation of Magnesium Alloy Surfaces for Painting
- D2370 Test Method for Tensile Properties of Organic Coatings
- D3330/D3330M Test Method for Peel Adhesion of Pressure-Sensitive Tape
- D3359 Test Methods for Measuring Adhesion by Tape Test

### 3. Summary of Test Method

3.1 Pressure-sensitive tape is adhered to the surface of the coating and then removed utilizing a motorized mechanical device that peels the tape at a constantly maintained angle and controlled rate of peel. A digital recording force gage is used to record the maximum peel force.

NOTE 1—All due care must be taken to ensure that test specimens are handled and stored such that they are not subjected to conditions that will cause deleterious effects. These conditions include but are not limited to handling without the use of gloves, storing in areas that accumulate dust, areas of high humidity or where the sample may be subjected to fumes or vapors that might condense on the sample.

#### 3.2 Methods A1 and A2:

3.2.1 In these methods, which are nondestructive, the measurement area used is the unbroken coating surface with peel angles of 90 and 180° respectively.

3.2.2 Adhesion is assessed in terms of “passed,” if the coating does not detach, or “failed,” if the coating detaches within the specified range of peel forces as recorded during the test.

#### 3.3 Methods B1 and B2:

3.3.1 In these methods, which are destructive, the measurement area used is a broken coating surface created by scoring a lattice pattern through the coating to the substrate and peeling at angles of 90 and 180°, respectively.

3.3.2 Adhesion is assessed qualitatively on the 0 to 5 scale.

### 4. Significance and Use

4.1 If a coating is to fulfill its function of protecting or imparting unique properties to the surface of a substrate, it must adhere to the substrate for the expected service life. Because surface preparation (or lack of it) has a drastic effect on adhesion of coatings, a test method for evaluating adhesion to different surface treatments or of different coatings to the same treatment is of considerable use to the industry.

4.2 The limitations of all adhesion methods, and the specific limitation of this test method to lower levels of adhesion (see 1.3) should be recognized before using it. These test methods are mechanized adaptations of Test Methods D3359; therefore, the intra- and interlaboratory precision of these test methods are similar to Test Methods D3359 and to other widely-accepted tests for coated substrates, for example, Test Method D2370, but this is partly the result of it being insensitive to all but large differences in adhesion. The pass-fail scale of 0 to 5 for Method B1 and B2 was selected deliberately to avoid a false impression of being sensitive.

### 5. Apparatus and Materials

5.1 *Peel Test Fixture*—The fixture shall consist of a frame to which the specimen is rigidly clamped, and a moveable beam by which the tape is pulled off under a constant peel angle of 90 (Method A1 and B1) or 180° (Method A2 and B2). The peel rate should be controllable between 20 mm/s and 200 mm/s for Method A1 and B1 and between 14 mm/s and 140 mm/s for Methods A2 and B2. A recording force gage is fitted between the tape grip and the movable beam (see Fig. 1).

5.2 *Pressure-Sensitive Tape*—Unless otherwise specified in the document referencing this test, the tape shall be 25 mm wide, semitransparent, pressure-sensitive tape with an adhesion strength of  $43 \pm 5.6$  g/mm or N/100 mm width when tested in accordance with D3330/D3330M. The adhesion shall not change by more than + 6.5 % of its mean value within 12 months. The backing of the tape may consist of fiber-reinforced cellulose acetate, unplasticized poly (vinyl chloride), or polyester film. When results obtained in different laboratories do not agree it is recommended that the test be repeated using tape from the same batch.

5.3 *Roller*—The roller,<sup>4</sup> which is hand operated, consists of a steel roller  $85 \pm 2.5$  mm in diameter and  $45 \pm 1.5$  mm in width, covered with rubber approximately 6 mm in thickness, having a Shore scale A durometer hardness of  $80 \pm 5$ . The surface of the roller shall be a true cylinder void of any concave or convex deviations. The mass of the roller shall be  $2040 \pm 45$  g.

NOTE 2—A standardized roller is used in place of the pencil eraser of Test Methods D3359 because of the variety of rubber and abrasives formulations used to make pencil erasers. A further consideration was the extended range of localized pressures that could be exerted by the pencil and eraser.

## TEST METHOD A NONDESTRUCTIVE, PARTS TAPE TEST

### 6. Test Specimen

6.1 *Parts*—This test normally is performed on parts. Any requirements for test specimens will be found in the document specifying their use.

NOTE 3—When specified by the document referencing this test, the coated parts shall be subjected to a preliminary exposure, such as water immersion, salt spray, or humidity, before conducting the tape test.

### 7. Procedure

7.1 *Test Area*—Select a flat area, on a significant surface, free of blemishes and minor surface imperfections. Ensure that the surface is clean and dry. Extremes in temperature or relative humidity may affect the adhesion of the tape or the coating.

7.2 *Tape Section*—Remove two complete laps of the pressure-sensitive tape from the roll and discard. Remove an

<sup>4</sup> The sole source of supply of the apparatus known to the committee at this time is Pressure-Sensitive Tape Council (PSTC), 104 Wilmot Rd., Suite 201, Deerfield, IL 60015. If you are aware of alternative suppliers, please provide this information to ASTM International Headquarters. Your comments will receive careful consideration at a meeting of the responsible technical committee,<sup>1</sup> which you may attend.



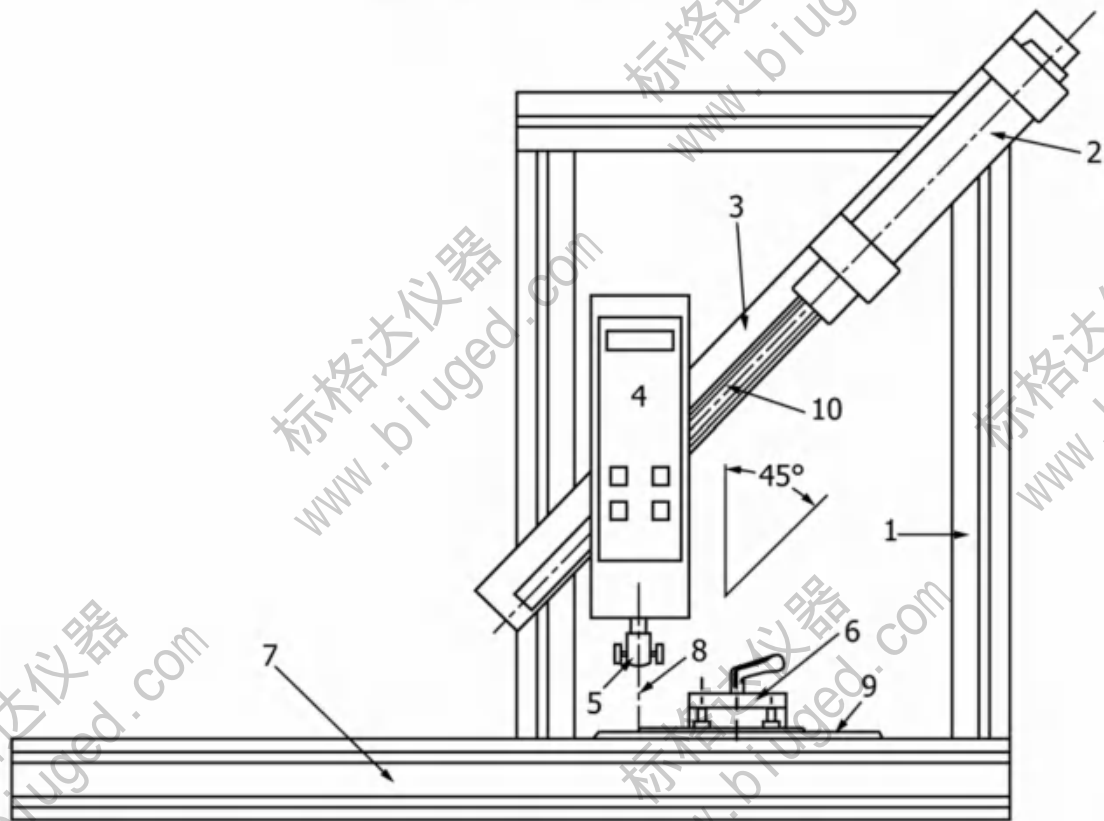

NOTE 1—Item 1 is the pneumatic cylinder traverse channel; 2 is the pneumatic pull cylinder; 3 is the pneumatic cylinder traverse which is shown in the 90° pull position; 4 is the digital force gage, which is attached to the piston rod; 5 is the tape grip; 6 is the part/specimen hold down; 7 is the fixture base; 8 is the free end of the tape; 9 is a coated specimen; 10 is the piston. By a simple displacement of the traverse, the fixture can be modified for 180° testing. The pull rate is adjustable between 20 and 250 mm/s.

FIG. 1 Schematic of Tape Test Fixture

additional length at a steady (that is, not jerked) rate and cut a piece off at least 100 mm long plus an additional length equal to the space between the test surface and the grip on the fixture for pulling the tape.

**7.3 Tape Placement**—Carefully place the tape on the area of coating to be tested and lightly press and smooth the tape into place, taking care to prevent any entrapment of air bubbles between the tape and the coating. Once the tape is in place, roll the tape firmly; once in each lengthwise direction (see 5.3). The color under the semi-transparent tape is a useful indication of when good contact has been made.

**7.4 Time, Rate, and Angle:**

7.4.1 Within  $90 \pm 30$  s of the tape application, fasten the specimen onto the fixture, placing the free end of the tape in the pulling grip. The apparatus should be set to maintain the normal 90° peel angle, Method A1 (see Notes 4 and 5).

7.4.2 Pull the tape at a constant rate until only about 20 mm of tape remains in contact with the coating. The residual adhering tape can be removed manually after assessing adhesion on the area peeled off. This final removing of the residual tape is not a constituent of the adhesion test.

NOTE 4—As far as possible, preference should be given to Method A1 (90° peel angle) due to the stress-strain behavior of the tape. If the coating to be tested is not approachable for 90° testing, for example, at the wall side inside a housing, Method A2 (180° peel angle) may be applied.

NOTE 5—At a peel angle of 90°, the peel rate of the tape from the coating surface is equal to the pull rate, that is, the velocity by which the free end of the tape is moved in the loading direction, whereas in a peel angle of 180°, the peel rate of the tape is only half the pull rate.

**7.5 Peel Force Control**—Read the maximum value of peel force recorded from the force registration gauge. If the force value recorded is greater than  $2.5 \text{ N} \pm$  the force value specified in the document referencing this test, the test shall be repeated. Use a correspondingly lower or higher rate of peel until the maximum value is within  $\pm 2.5 \text{ N}$ .

NOTE 6—For metallic coatings on polymeric substrates, the typical force range is:

- 15 N – 25 N for Method A1
- 20 N – 35 N for Method A2

**7.6 Evaluation**—Inspect both the area of coating and the tape for evidence of flaking or detachment. Repeat the test at another area of the part. Perform sufficient tests to ensure that the adhesion evaluation is representative of the whole surface.

**8. Report**

- 8.1 The test report shall contain the following:
  - 8.1.1 Method (A1 or A2),
  - 8.1.2 Type of coating,
  - 8.1.3 Any intermediate layers,
  - 8.1.4 Substrate material,



- 8.1.5 Type of tape used,
  - 8.1.6 Peel angle,
  - 8.1.7 Rate of peel,
  - 8.1.8 Any environmental exposure, and
  - 8.1.9 Any failure at intermediate layers.
- 8.2 Report the test results as:

$$\frac{p/F_{max}}{\text{OR}} \quad (1)$$

$$\frac{f/F_{max}}{\text{OR}} \quad (2)$$

where:

- $p$  = passed (no coating detachment),
- $f$  = failed (coating detachment), and
- $F_{max}$  = maximum registered peel force.

### 9. Precision of Test Method A

9.1 An interlaboratory study of this test method reviewed tape peel measurements on various coatings under several peel conditions. The results showed that maximum peel force of the tape depended significantly on the type of coating, the type of tape, the peel rate and the peel angle. There was an insignificant relationship to the pressure used for adhering the tape to the coating.

9.2 The results of coating adhesion assessments obtained on different coatings should only be compared when the maximum deviation recorded, does not exceed  $\pm 2.5$  N.

9.3 The results of coating adhesion assessments obtained with Method A1 should not be compared with the results obtained with Method A2.

## TEST METHOD B DESTRUCTIVE, CROSS CUT TAPE TEST FOR LABORATORY INVESTIGATION

### 10. Apparatus and Materials

10.1 In addition to the apparatus and materials in 5.1 the following also are required:

10.1.1 *Cutting Tool*—A sharp razor blade, scalpel, knife or other cutting device having a cutting edge angle between 15 and 30° that will make either a single cut or several cuts at once. It is of particular importance that the cutting edge be in good condition.

10.1.2 *Cutting Guide*—If cuts are made manually (as opposed to a mechanical apparatus) a steel or other hard metal straight edge or template should be used to ensure straight cuts.

10.1.3 *Rule*—A tempered steel rule graduated in 0.5 mm units is required for measuring individual cuts.

10.1.4 *Illumination*—A light source is recommended for determining whether the cuts have been made through the film to the substrate.

10.1.5 *Magnifying Glass*—An illuminated magnifier to be used while making individual cuts and examining the test area.

### 11. Test Specimen

11.1 Test panels shall be approximately 75 by 150 mm and at least 0.4 mm thick. Apply the coating and preparation

procedure to be tested to the panels of the composition and surface conditions on which it is desired to determine adhesion.

Note 7—Information on test panels and surface preparation methods are given in Practices B183, B242, B254, B281, B320, B343, B481, B482, B537, B629, B630, B727, D1730, D1731, and D1732; Guides B252, B253, and B480; and Method B538.

### 12. Procedure

12.1 *Test Area*—Select an area free of blemishes and minor surface imperfections. Assure that the surface is clean and dry. Extremes in temperature or relative humidity may affect the adhesion of the tape or the coating.

12.2 *Scribing the First Series of Lines*—Place the panel on a firm base and under the illuminated magnifier make parallel cuts as follows:

12.2.1 Space the cuts 4 mm apart and make six cuts (see Note 8). Make all cuts about 20 mm long. Cut through the film to the substrate in one steady motion using just sufficient pressure on the cutting tool to have the cutting edge reach the substrate. When making successive single cuts with the aid of a guide, place the guide on the uncut area. After making the six cuts, brush the film lightly with a soft brush or tissue to remove any detached flakes or ribbons of coating.

Note 8—Scribed lines in metallic coatings often result in vertical displacements from the coating surface. These displacements interfere with the proper adhesion of the tape and the circumscribed areas particularly when closer than 4 mm apart. This can result in questionable adhesion passing this test.

12.3 *Scribing the Second Series of Lines*—Prior to scribing the second series of lines examine the cutting edge and, if necessary, remove any flat spots or wire-edge by abrading lightly on a fine oil stone. Cut the second series of six lines spaced 4 mm apart at 90° to and centered on the first series of lines (see Note 8). Brush the area as before and inspect the incisions for reflection of light from the substrate. If the substrate has not been reached make another grid in a different location.

12.4 *Tape Section*, see 7.2.

12.5 *Tape Placement*—Carefully place the tape over the cross-hatch area of the coated test panel and lightly press and smooth the tape into place, taking care to prevent any entrapment of air bubbles between the tape and the coating. Once the tape is in place, roll the tape firmly once in each lengthwise direction see 5.3). The color under the semitransparent tape is a useful indication of when good contact has been made.

12.6 *Time, Rate, and Angle*—Within  $90 \pm 30$  s of the tape application, fasten the test panel onto the fixture placing the free end of the tape in the pulling grip. The apparatus should be set to maintain the normal 90° peel angle, Method B1 (see Notes 4 and 8). Pull the tape at a constant rate until only about 20 mm of tape remains in contact with the coating. The residual adhering tape can be removed manually after assessing adhesion on the area peeled off. This final removing of the residual tape is not a constituent of the adhesion test.

Note 9—As far as possible, preference should be given to Method B1 (90° peel angle) due to the stress-strain behavior of the tape. If the coating

to be tested is not approachable for 90° testing Method B2 (180° peel angle) may be applied.

12.7 *Peel Force Control*, see 7.5.

12.8 *Evaluation*—Using the illuminated magnifier, inspect the grid area for removal of coating from the substrate or from an intermediate coating. Rate the adhesion in accordance with the following scale illustrated in Fig. 2 and described as follows:

- 5 The edges of the cuts are completely smooth; none of the squares of the lattice are detached.
- 4 Small flakes of the coating are detached at intersections; less than 5 % of the area is affected.
- 3 Small flakes of the coating are detached along edges and at intersections of cuts. The area affected is 5 to 15 % of the lattice.
- 2 The coating has flaked along the edges and on parts of the squares. The area affected is 15 to 35 % of the lattice.
- 1 The coating has flaked along the edges of cuts in large ribbons and whole squares have detached. The area affected is 35 to 65 % of the lattice.
- 0 Flaking and detachment worse than Grade 1.

Repeat the test in two other locations on each test panel.

13. Report

13.1 The test report shall contain the following information:

- 13.1.1 Method (B1 or B2),
- 13.1.2 Type of coating,
- 13.1.3 Any intermediate layers,
- 13.1.4 Substrate material,
- 13.1.5 Type of tape used,
- 13.1.6 Peel angle,
- 13.1.7 Rate of peel,
- 13.1.8 Any environmental exposure, and
- 13.1.9 Any failure at intermediate layers.

13.2 Report the test results as follows:

$$C/F_{max} \quad (3)$$

where:

- C = Classification number according to Fig. 2, and
- F<sub>max</sub> = maximum registered peel force.

Classification of Adhesion Test Results





Classification	Surface of cross-cut area from which flaking has occurred. (Example for six parallel cuts)
5	None
4	
3	
2	
1	
0	Greater than 65%

FIG. 2 Example of Cross-Hatch Ratings



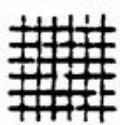

#### 14. Precision of Method B

14.1 The results of coating adhesion assessments obtained on different coatings should only be compared when the maximum deviation recorded, does not exceed  $\pm 2.5$  N.

14.2 The results of coating adhesion assessments obtained with Method B1 should not be compared with the results obtained with Method B2.

*ASTM International takes no position respecting the validity of any patent rights asserted in connection with any item mentioned in this standard. Users of this standard are expressly advised that determination of the validity of any such patent rights, and the risk of infringement of such rights, are entirely their own responsibility.*

*This standard is subject to revision at any time by the responsible technical committee and must be reviewed every five years and if not revised, either reapproved or withdrawn. Your comments are invited either for revision of this standard or for additional standards and should be addressed to ASTM International Headquarters. Your comments will receive careful consideration at a meeting of the responsible technical committee, which you may attend; if you feel that your comments have not received a fair hearing you should make your views known to the ASTM Committee on Standards, at the address shown below.*

*This standard is copyrighted by ASTM International, 100 Barr Harbor Drive, PO Box C700, West Conshohocken, PA 19428-2959, United States. Individual reprints (single or multiple copies) of this standard may be obtained by contacting ASTM at the above address or at 610-832-9585 (phone), 610-832-9555 (fax), or service@astm.org (e-mail); or through the ASTM website (www.astm.org). Permission rights to photocopy the standard may also be secured from the Copyright Clearance Center, 222 Rosewood Drive, Danvers, MA 01923. Tel: (978) 646-2600; <http://www.copyright.com/>*

标格达仪器  
www.biuged.com

标格达仪器  
www.biuged.com

标格达仪器  
www.biuged.com

标格达仪器  
www.biuged.com

标格达仪器  
www.biuged.com

标格达仪器  
www.biuged.com

标格达仪器  
www.biuged.com

标格达仪器  
www.biuged.com

标格达仪器  
www.biuged.com

标格达仪器  
www.biuged.com

标格达仪器  
www.biuged.com

标格达仪器  
www.biuged.com

标格达仪器  
www.biuged.com

标格达仪器  
www.biuged.com

标格达仪器  
www.biuged.com

标格达仪器  
www.biuged.com

标格达仪器  
www.biuged.com

标格达仪器  
www.biuged.com

标格达仪器  
www.biuged.com

标格达仪器  
www.biuged.com