



Designation: C633 – 13

Standard Test Method for Adhesion or Cohesion Strength of Thermal Spray Coatings¹

This standard is issued under the fixed designation C633; the number immediately following the designation indicates the year of original adoption or, in the case of revision, the year of last revision. A number in parentheses indicates the year of last reapproval. A superscript epsilon (ϵ) indicates an editorial change since the last revision or reapproval.

This standard has been approved for use by agencies of the U.S. Department of Defense.

1. Scope

1.1 This test method covers the determination of the degree of adhesion (bonding strength) of a coating to a substrate or the cohesion strength of the coating in a tension normal to the surface. The test consists of coating one face of a substrate fixture, bonding this coating to the face of a loading fixture, and subjecting this assembly of coating and fixtures to a tensile load normal to the plane of the coating. It is adapted particularly for testing coatings applied by thermal spray, which is defined to include the combustion flame, plasma arc, two-wire arc, high-velocity oxygen fuel, and detonation processes for spraying feedstock, which may be in the form of, wire, rod, or powder.

Note 1—Thermal spray coating materials include ceramics, such as metal oxides or carbides, and metals. In some cases, a coating is formed of different spray materials, such as an oxide layer sprayed onto a sprayed metal-bonding layer. The substrate generally is a metal, but may be a ceramic, such as an oxide or graphite.

1.2 Usually this test method is performed at ambient temperature. Higher temperature testing is restricted by the need for a suitable adhesive bonding agent. For certain fundamental investigations, it is suggested that very low (cryogenic) temperature be used.

1.3 This test method is limited to testing thermal spray coatings that can be applied in thickness greater than 0.015 in. (0.38 mm). The limitation is imposed because an adhesive bonding agent is used in the test. Those bonding agents established so far for this method tend to penetrate thermal spray coatings and may invalidate results unless the coatings are thick enough to prevent penetration through the coating. Further development may establish that thin layers of certain types of especially dense coatings may be tested satisfactorily. Alternatively, new adhesive bonding agents that would allow reduction of the minimum thickness limitation may become available.

¹ This test method is under the jurisdiction of ASTM Committee B08 on Metallic and Inorganic Coatings and is the direct responsibility of Subcommittee B08.12 on Materials for Porcelain Enamel and Ceramic-Metal Systems.

Current edition approved Dec. 1, 2013. Published December 2013. Originally approved in 1969. Last previous edition approved in 2008 as C633 – 01(2008). DOI: 10.1520/C0633-13.

1.4 The values stated in inch-pound units are to be regarded as standard. The values given in parentheses are mathematical conversions to SI units that are provided for information only and are not considered standard.

1.5 *This standard does not purport to address all of the safety concerns, if any, associated with its use. It is the responsibility of the user of this standard to establish appropriate safety and health limitations prior to use.*

2. Referenced Documents

2.1 *ASTM Standards:*²

E4. Practices for Force Verification of Testing Machines

3. Significance and Use

3.1 This test method is recommended for quality control, acceptance testing; or it may help to develop or qualify a thermal spray operator's equipment and procedure or to aid in developing thermal spray coatings with improved adhesion and integrity.

3.2 This test method is useful for comparing adhesion or cohesion strengths of coatings of similar types of thermal spray materials. The test should not be considered to provide an intrinsic value for direct use in making calculations, such as to determine if a coating will withstand specific environmental stresses. Because of residual stresses in thermal spray coatings, actual strength depends upon the shape of the particular coated part. Also, in use, a coating may be stressed in a more complex manner than is practical for a standard test.

4. Apparatus

4.1 A tension testing machine shall conform to the requirements of Practices E4. The loads used in determining the adhesion or tensile strength shall be within the loading range of the testing machine, as defined in Practices E4. Permissible variation shall be less than 1.0 %. It shall be possible to apply increasing tensile load at a constant rate of cross-head travel between 0.030 in./min (0.013 mm/s) and 0.050 in./min (0.021

² For referenced ASTM standards, visit the ASTM website, www.astm.org, or contact ASTM Customer Service at service@astm.org. For *Annual Book of ASTM Standards* volume information, refer to the standard's Document Summary page on the ASTM website.

mm/s). The machine shall include a load-indicating device that registers the maximum load applied before rupture occurs.

4.2 Self-aligning devices, for applying the tensile load to the assembly of the coating and fixtures, shall not permit eccentric load or bending moment to the specimen. Self-alignment is often provided by the manufacturer as an integral part of the testing machine. An alternative, satisfactory apparatus is shown in Fig. 1, which also shows methods of connecting the self-aligning apparatus to an assembled test specimen.

5. Material

5.1 Adhesive Bonding Agent—A suitable adhesive bonding agent shall be agreed between the purchaser and manufacturer of the coating and shall meet the following requirements.³

5.1.1 The bonding agent shall be capable of bonding the coating to the loading fixture with a tensile strength that is at least as great as the minimum required adhesion and cohesion strength of the coating.

5.1.2 The bonding agent shall be sufficiently viscous not to penetrate through a 0.015-in. (0.38-mm) thickness of the coating. Certain commercial resins that cure or harden at room temperature by means of a curing agent have been proven satisfactory. If any other bonding agent is to be used, it shall first be compared with a proven bonding agent using this test method with the desired thermal spray coating.

NOTE 2—Thermal spray coatings may have an inherent porosity. Excessive penetration of the adhesive bonding agent into this porosity may affect the results determined by this test method. Unless proved satisfactory by comparison testing, any agent requiring elevated temperature for curing should be avoided because viscosity may decrease at high temperature, allowing penetration.

NOTE 3—When liquid epoxy bonding agents are used, there should be

³ A list of satisfactory bonding agents is provided in the annex which follows this standard.

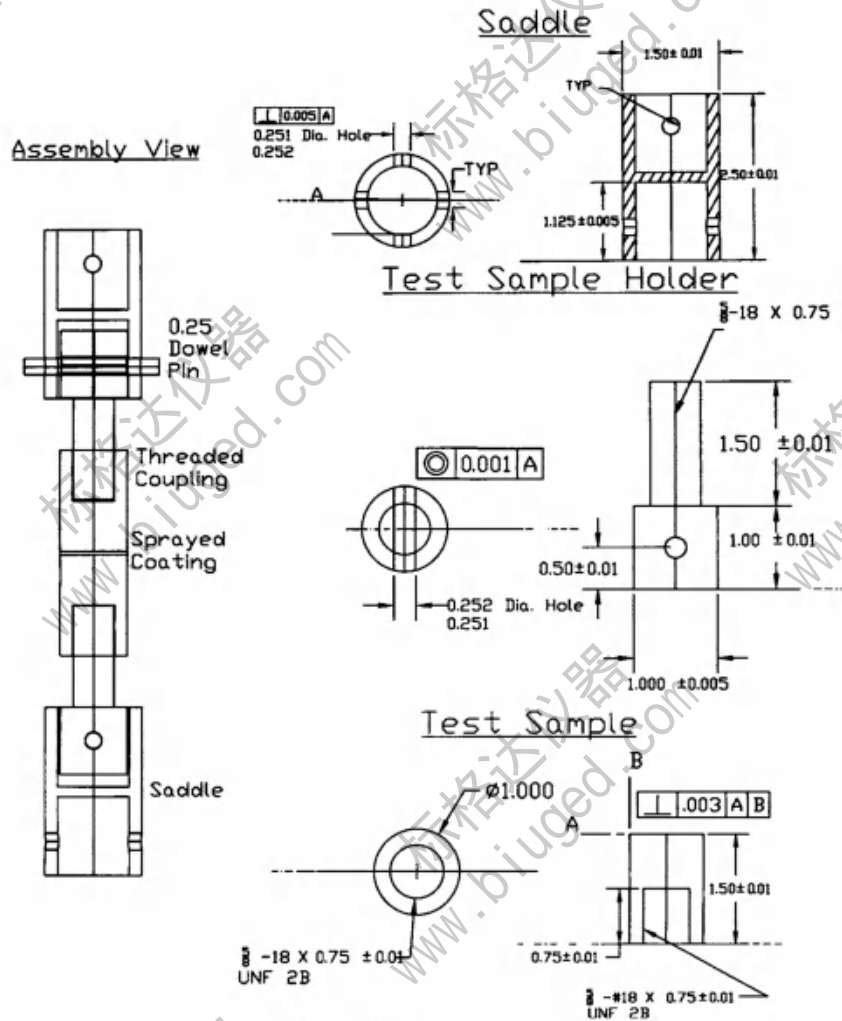

Metric Equivalents

in.	3/16	1/4	3/4	1	1 1/8	1 1/4	1 1/2	2 1/2
(mm)	(4.8)	(6.4)	(19)	(25.4)	(29)	(37)	(38)	(64)

FIG.-1 Self-Aligning Device

a procedure in place to ensure relatively consistent thickness on every sample.

5.1.3 The adhesion strength of the bonding agent shall be determined each time this test method is performed. This shall be done by using the bonding agent to attach a loading fixture to a second loading fixture, in accordance with 6.5, except that the coated substrate fixture of 6.5 is replaced with the second loading fixture.

NOTE 4—One reason for testing the bonding agent each time is to detect improper preparation of the agent if it is a two-part mix. Another reason is that adhesion strength generally decreases with age of the unused agent. If strength is lower than required, more adhesive bonding agent shall be prepared and tested, or the agent shall be discarded and replaced.

6. Test Specimens

6.1 *Substrate and Loading Fixtures*— Each test specimen is an assembly comprising a substrate fixture, to which the coating is applied, and a loading fixture. The substrate and loading fixtures shall each be circular, solid cylinders of no less than 1.5 in. in length, or as agreed upon by the manufacturer and customer. A suggested detail for either fixture is shown in Fig. 2. One end of each fixture shall be adapted for attachment

to the self-aligning loading devices of the tension testing machine. Both ends of each fixture shall have faces parallel to each other and normal to the loading axis. The facing diameters shall be not less than 0.9 in. (23 mm), nor more than 1.0 in. (25 mm). The diameters of the two fixtures shall be the same and shall be measured so that the error is no greater than 0.5 %.

NOTE 5—In Appendix X1, an alternative substrate and fixture arrangement is provided that has proved cost effective and simple.

6.1.1 *Material for Substrate Fixture*— The substrate fixture shall be constructed of metal, preferably metal intended for use as the substrate for the coating. If no such substrate material is specified, the substrate fixture shall be SAE 1018 or 1020 steel.

NOTE 6—If desired because of cost or ease of fabrication, it may be suitable to attach or bond a layer of the specified substrate material to a fixture formed of any convenient metal. Such a layer of substrate material need not be metal. The layer must be substantially thicker than the possible depth of effects on the substrate, such as recrystallization or diffusion zones, that may result from applying the coating. A layer greater than 0.1 in. (2.5 mm) thick should be sufficient.

6.1.2 *Material for Loading Fixture*—The loading fixture shall be constructed of metal, but material is otherwise optional. It is usually convenient to make the loading fixture of

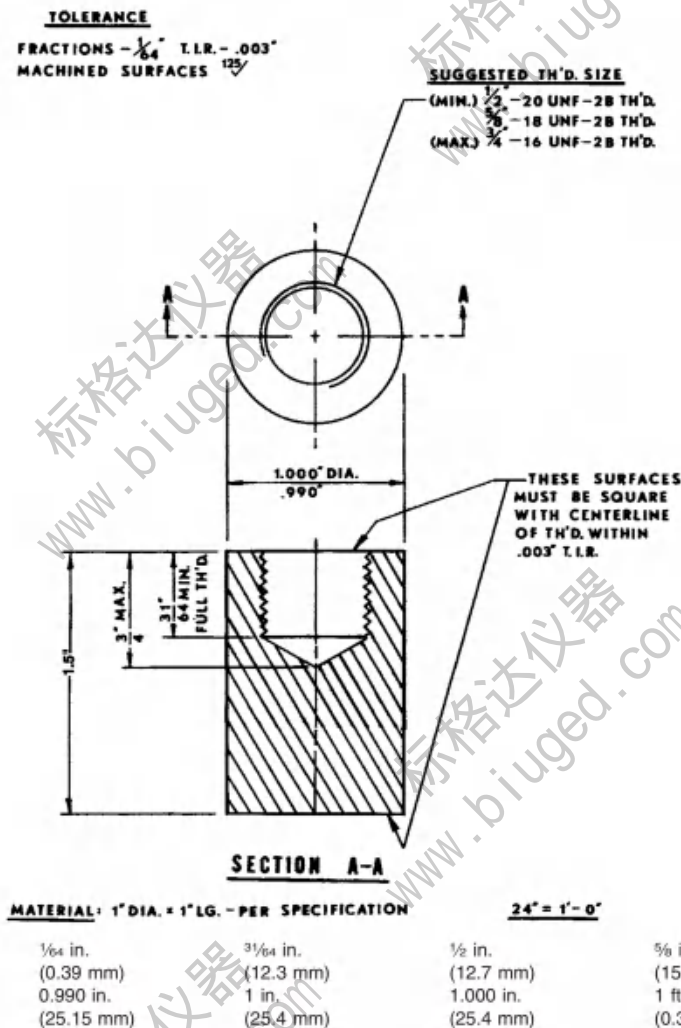

FIG. 2 Substrate and Loading Fixture

the same material as the substrate fixture; thus, the fixtures may be interchangeable until a coating is applied to one.

6.2 Coating Application—The front facing of the substrate fixture shall be prepared in the manner required by the specification for the coating. (Roughening by grit blasting or surface grinding may be typical preparations.) The coating shall be thermal sprayed onto this prepared surface.

6.3 Coating Thickness—The coating thickness shall be measured with a micrometer by measuring the total length of the coating fixture before and after the coating is applied. (Care must be taken to avoid contaminating the prepared surface before coating.) The final coating thickness shall be more than 0.015 in. (0.38 mm). If the coating is to be ground or machined, the as-sprayed coating shall be approximately 0.005 in. (0.13 mm) thicker to allow for removal of material. The coating thickness shall not vary across the surface by more than 0.001 in. (0.025 mm). (This thickness variation, as measured from the rear face, does not refer to the ordinary surface texture or roughness typical of thermal spray coatings.) If, upon completion of the thermal spraying, the coating thickness varies in excess of this limit, this shall be corrected by removing the coating and respraying or by grinding or machining the coating surface.

6.4 Grinding or Machining the Coating Surface—The surface of the coating may be finished by grinding or machining when the thickness variation is excessive. If the thickness variation is not excessive, it shall be optional to finish the surface of the coating as a useful and convenient aid in holding the fixtures together parallel and aligned as required for the next step. No specific grinding or machining procedure can be recommended, as this depends on the type of coating material. Usually manufacturers of the coatings have recommendations published or available. Only a rough grinding or machining step is needed, to provide a final coating thickness that does not vary by more than 0.001 in. (0.025 mm). Removal rate shall be insufficient to damage the coating or bond. A recommended method is to use a surface grinder with a magnetic chuck, positioning the rear face of the coated fixture on this magnetic chuck. No other treatment, such as grit blasting, shall be done to the surface of the coating.

6.5 Attachment of Fixtures—The facing of the loading fixture shall be free of oil, grease, or grinding or cutting fluids. The facing shall be mechanically cleaned by such means as machining, grinding, light grit blasting, or rubbing with emory cloth. This facing shall be attached to the surface of the coating, using the adhesive bonding agent according to its manufacturer's instructions. Excessive adhesive shall be wiped from the assembly with soft paper or cloth. The two fixtures shall be held together parallel and aligned until the bonding agent is cured or hardened. A suitable holding device such as a "V-block" shall be used for the purpose, except such a device is not necessary if the surface of the coating has been ground or machined smooth.

6.6 Number of Test Specimens—The number of test specimens chosen depends upon the purpose of the particular tests under consideration. However, if specimens are to be used for acceptance tests, not less than five specimens of a type shall be tested.

7. Procedure

7.1 Prepare the chosen number of substrate fixtures, and apply a thermal spray coating to each. Finish the coating surface if required.

7.2 Prepare the adhesive bonding agent. Attach cleaned loading fixtures to all the coated substrate fixtures at essentially the same time. In addition, prepare one set of uncoated fixtures for measurement of the adhesion strength of the bonding agent.

7.3 Apply a tensile load to each test specimen at a constant rate of cross-head travel between 0.030 in./min (0.013 mm/s) and 0.050 in./min (0.021 mm/s) until rupture occurs. Record the maximum load applied.

NOTE 7—Loading fixtures may be gravity or pressure devices. The design of the loading fixtures should enable the correct alignment of the specimen.

8. Calculation

8.1 Calculate the degree of adhesion or cohesion strength as follows:

$$\begin{aligned} &\text{Adhesion or cohesion strength} && (1) \\ &= \text{maximum load/cross-sectional area} \end{aligned}$$

9. Interpretation of Results

9.1 Any interpretation of results depends on the purpose of using this test method and on the description of failure. The adhesion or cohesion strength value measured represents the weakest part of the system, whether in the coating or at an interface. A low-power microscope with a magnification range up to 100x is suggested for determining location of failure (also termed as the "locus" of failure).

9.2 The adhesion strength of the coating is given if failure is entirely at the coating-substrate interface.

9.3 The cohesion strength of the coating is given if rupture is only within the coating. Failure in the bonding agent may be a satisfactory result for a quality control assurance test or for a qualification test, if the strength of the bonding agent is greater than the minimum required adhesion or cohesion strength of the coating.

9.4 If failure occurs in a combination of these locations in one specimen, generally no interpretation of the initial cause can be provided. Fig. 3 diagrams the possible modes of failure.

9.5 For a multicomponent system; for example, a bond coat with a ceramic overlay, then failure at the interface between two coatings is described as "internal adhesive."

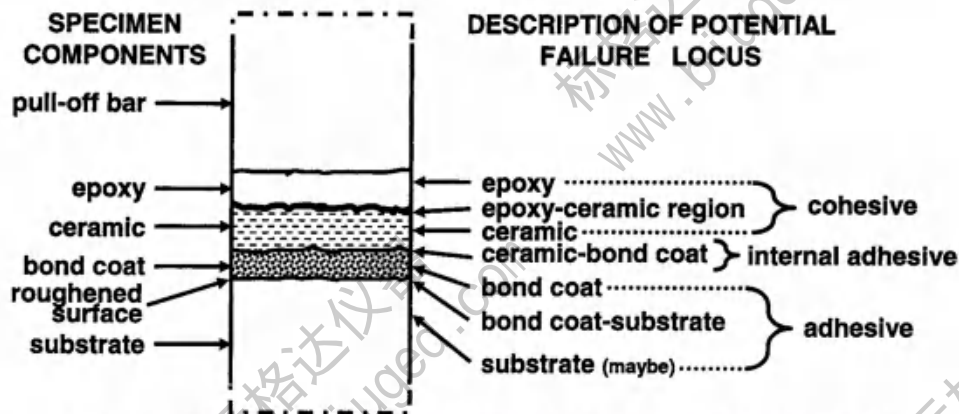

FIG. 3 Nomenclature of Specimen Components and Classification of Failure Loci

10. Report

- 10.1 The report shall include the following:
 - 10.1.1 Coating material or manufacturer's designation technique used to apply the coating, including type of thermal spray equipment, and spray parameters.
 - 10.1.2 Final coating thickness and statement of whether surface is finished or as-sprayed.
 - 10.1.3 Substrate material.
 - 10.1.4 Description of surface preparation of substrate.
 - 10.1.5 Name or description of bonding agent and details of bonding procedure if different from manufacturer's instructions.
 - 10.1.6 Number of thermal spray specimens and number of specimens tested.
 - 10.1.7 The adhesion or cohesion strength of each specimen tested.
 - 10.1.8 Average adhesion and cohesion strength, and the maximum and minimum values, in pounds per square inch (or pascals).
 - 10.1.9 Description of failure, including statement of whether failure occurred at the coating-substrate interface, in the coating, in the bonding agent, or a combination of these. For multilayered coatings, an internal adhesion failure also must be indicated if it is present. Fig. 3 diagrams the possible modes of failure.

10.1.10 Adhesion strength of the bonding agent in the test specimen without a thermal spray coating.

11. Precision and Bias

11.1 No justifiable statements can be made regarding the precision and bias of this test method because it evaluates coatings that exhibit brittle fracture, an unpredictable characteristic.

11.2 This test method is applicable to a wide variety of materials with different characteristics.

11.3 Since design, base metal composition, fabrication, and processing, as well as thermal spraying the coating, will give rise to variables in adherence, each application of this test method should have tolerances and interpretation of adherence set and agreed upon between the purchaser and the manufacturer.

12. Keywords

12.1 adhesion strength; cohesion strength; fracture locus; thermal spray coatings

ANNEX

(Mandatory Information)

A1. ADHESIVE BONDING AGENTS FOR ATTACHMENT OF LOADING FIXTURE TO THERMAL SPRAY COATINGS

A1.1 The following adhesive is recommended for attaching the loading fixture to thermal spray coatings that are primarily metallic or that have a metal matrix. It is not recommended for thermal spray oxide or other porous ceramic coatings because of the possibility of excessive penetration into the coating.

A1.1.1 Cytec FM-1000, available from Cytec Industries Inc., 5 Garret Mountain Plaza, Woodland Park, NJ 07424 (<http://www.cytec.com/engineered-materials/aas>

[SOScenter.html](http://www.cytec.com/engineered-materials/aas/SOScenter.html)). This is a one-part mix that is cured at 375 °F (190 °C) for a minimum of 1 h. When the adhesive is new, typical adherence strength to thermal spray coatings may range up to approximately 10 000 psi (69 MPa) depending on the coating material.

A1.2 The following adhesives are recommended for attaching the loading fixture to thermal spray coatings of any type, ceramic or metallic. These are two-part mixes that should be

cured at room temperature when used for this test method. When the adhesive is new, typical adherence strength to thermal spray coatings may range up to approximately 4 000 psi (28 MPa) depending on the coating material.

A1.2.1 Magna-Tac M666 (http://www.beaconadhesives.com/TechSheets/magna-tac_m666.htm) or M777 (<http://www.beaconadhesives.com/TechSheets/m777.htm>), manufactured by Beacon Adhesives Co., Inc., 125 MacQuieslan Parkway South, Mount Vernon, NY 10550. Products were formerly known as Bondmaster M666 and M777. M777 may be easier to use as it may be more viscous than M666.

A1.2.2 Armstrong A-12 (<http://apps.ellsworth.com/library/Library/TDS/en/TDS16909.pdf>), manufactured by Resin Technology Group, LLC, 28 Norfolk Avenue, Easton, MA 02375. Armstrong Products Co., Argonne Rd., Warsaw, IN 46580.

A1.2.3 3M Scotch Weld Epoxy Adhesive EC-2214, sold by 3M Industrial Adhesives and Tapes Division, 3M Center, St. Paul, MN 55144-100.

APPENDIX

X1. ALTERNATIVE SUBSTRATE AND FIXTURE ARRANGEMENT

X1.1 See Fig. X1.1 for an alternative substrate and fixture arrangement that has proved cost effective and simple.

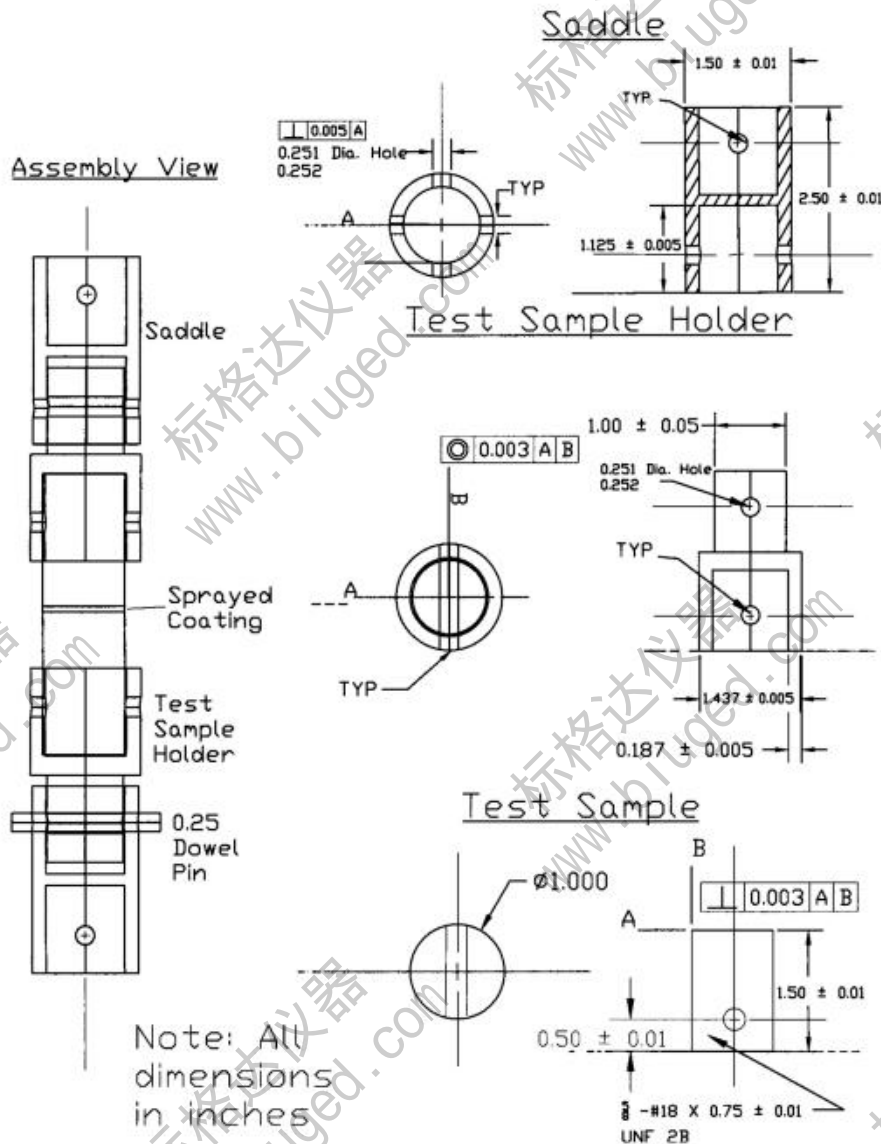

FIG. X1.1 Alternative Load Train Geometry for Test Assembly

BIBLIOGRAPHY

- (1) F. J. Hermanek, "Determining the Adhesive and Cohesive Strengths of Thin Thermally Sprayed Coatings," *Welding J.*, Vol 57, 1978, pp. 31-35.
- (2) P. Ostojic and C. C. Berndt, "Variability in Strength of Thermally Sprayed Coatings," *J. Surf. Coat. Tech.*, Vol 34, 1988, pp. 43-50.
- (3) C. C. Berndt, "Tensile Adhesion Testing Methodology for Thermally Sprayed Coatings," *ASM J. Mater. Eng.*, Vol. 12, No. 2, 1990, pp. 151-160.
- (4) W. Han, E. F. Rybicki, and J. R. Shadley, "An Improved Specimen Geometry for ASTM C633-79 to Estimate Bonds Strengths of Thermal Spray Coatings," *J. Thermal Spray Technology*, Vol. 2, No. 2, 1993, pp. 145-150.
- (5) C. K. Lin and C. C. Berndt, "Measurement and Analysis of Adhesion Strength for Thermally Sprayed Coatings," *J. Thermal Spray Technology*, Vol. 3, No. 1, 1994, pp. 75-104.
- (6) D. J. Greving, J. R. Shadley, and E. F. Rybicki, "Effects of Coating Thickness and Residual Stresses on the Bond Strength of ASTM C633-79 Thermal Spray Coating Test Specimens," *J. Thermal Spray Technology*, Vol. 3, No. 4, 1994, pp. 371-378.

 **C633 – 13**

ASTM International takes no position respecting the validity of any patent rights asserted in connection with any item mentioned in this standard. Users of this standard are expressly advised that determination of the validity of any such patent rights, and the risk of infringement of such rights, are entirely their own responsibility.

This standard is subject to revision at any time by the responsible technical committee and must be reviewed every five years and if not revised, either reapproved or withdrawn. Your comments are invited either for revision of this standard or for additional standards and should be addressed to ASTM International Headquarters. Your comments will receive careful consideration at a meeting of the responsible technical committee, which you may attend. If you feel that your comments have not received a fair hearing you should make your views known to the ASTM Committee on Standards, at the address shown below.

This standard is copyrighted by ASTM International, 100 Barr Harbor Drive, PO Box C700, West Conshohocken, PA 19428-2959, United States. Individual reprints (single or multiple copies) of this standard may be obtained by contacting ASTM at the above address or at 610-832-9585 (phone), 610-832-9555 (fax), or service@astm.org (e-mail); or through the ASTM website (www.astm.org). Permission rights to photocopy the standard may also be secured from the ASTM website (www.astm.org/COPYRIGHT).