



Designation: D2247 – 15

Standard Practice for Testing Water Resistance of Coatings in 100 % Relative Humidity¹

This standard is issued under the fixed designation D2247; the number immediately following the designation indicates the year of original adoption or, in the case of revision, the year of last revision. A number in parentheses indicates the year of last reapproval. A superscript epsilon (ϵ) indicates an editorial change since the last revision or reapproval.

This standard has been approved for use by agencies of the U.S. Department of Defense.

1. Scope*

1.1 This practice covers the basic principles and operating procedures for testing water resistance of coatings by exposing coated specimens in an atmosphere maintained at 100 % relative humidity so that condensation forms on all surfaces of test specimens.

1.2 This practice uses the technique of creating a slight temperature differential within the exposure area to form condensation on the coated specimens. As the warmer saturated air passes the cooler specimens, water is deposited onto the specimens in the form of condensation.

1.3 This practice places the entire specimen in the exposure area allowing condensation to form on all surfaces. This makes this practice suitable for flat panels as well as large or 3D objects. This practice differs from other methods where condensation is only formed on the front coating surface, while the back surface is outside the exposure area. Other tests may also deposit water droplets on the surface but where the source is not from condensation (for example, water-spray).

NOTE 1—Alternative practices for testing the water resistance of coatings include Practices D870, D1735, and D4585.

1.4 This practice is limited to the methods of obtaining, measuring, and controlling the conditions and procedures of tests conducted in 100 % relative humidity. It does not specify specimen preparation, or evaluation of results.

1.5 The values stated in SI units are to be regarded as the standard. The values given in parentheses are for information only.

1.6 *This standard does not purport to address all of the safety concerns, if any, associated with its use. It is the responsibility of the user of this standard to establish appropriate safety and health practices and determine the applicability of regulatory limitations prior to use.*

¹ This practice is under the jurisdiction of ASTM Committee D01 on Paint and Related Coatings, Materials, and Applications and is the direct responsibility of Subcommittee D01.27 on Accelerated Testing.

Current edition approved Dec. 1, 2015. Published December 2015. Originally approved in 1966. Last previous edition approved in 2011 as D2247 – 11. DOI: 10.1520/D2247-15.

2. Referenced Documents

2.1 ASTM Standards:²

- D609 Practice for Preparation of Cold-Rolled Steel Panels for Testing Paint, Varnish, Conversion Coatings, and Related Coating Products
- D610 Practice for Evaluating Degree of Rusting on Painted Steel Surfaces
- D714 Test Method for Evaluating Degree of Blistering of Paints
- D823 Practices for Producing Films of Uniform Thickness of Paint, Varnish, and Related Products on Test Panels
- D870 Practice for Testing Water Resistance of Coatings Using Water Immersion
- D1193 Specification for Reagent Water
- D1654 Test Method for Evaluation of Painted or Coated Specimens Subjected to Corrosive Environments
- D1730 Practices for Preparation of Aluminum and Aluminum-Alloy Surfaces for Painting
- D1735 Practice for Testing Water Resistance of Coatings Using Water Fog Apparatus
- D2616 Test Method for Evaluation of Visual Color Difference With a Gray Scale
- D3359 Test Methods for Measuring Adhesion by Tape Test
- D3363 Test Method for Film Hardness by Pencil Test
- D4541 Test Method for Pull-Off Strength of Coatings Using Portable Adhesion Testers
- D4585 Practice for Testing Water Resistance of Coatings Using Controlled Condensation

3. Summary of Practice

3.1 Coated specimens are placed in an enclosed chamber containing a heated, saturated mixture of air and water vapor. The temperature of the chamber is usually maintained at 38°C (100°F). At 100 % relative humidity (RH), a very small temperature difference between the specimen and the surrounding vapor causes the formation of condensation on the specimens. The exposure condition is varied by selecting the

² For referenced ASTM standards, visit the ASTM website, www.astm.org, or contact ASTM Customer Service at service@astm.org. For *Annual Book of ASTM Standards* volume information, refer to the standard's Document Summary page on the ASTM website.

*A Summary of Changes section appears at the end of this standard

duration of the test. Water permeates the coating at rates that are dependent upon the characteristics of the coating. Any effects such as color change, blistering, loss of adhesion, softening, or embrittlement are observed and reported.

4. Significance and Use

4.1 Water can cause the degradation of coatings, so knowledge of how a coating resists water is helpful for assessing how it will perform in actual service. Failure in tests at 100 % relative humidity may be caused by a number of factors including a deficiency in the coating itself, contamination of the substrate, or inadequate surface preparation. This practice is therefore useful for evaluating coatings alone or complete coating systems.

4.2 Tests at 100 % relative humidity are used for specification acceptance, quality control, and research and development for coatings and substrate treatments. Some tests are used for a pass or fail determination at an arbitrary time. A coating system is considered to pass if there is no evidence of water-related failure after a period of time. Other tests are used to monitor degree of failure as a function of exposure time.

4.2.1 Arbitrary pass/fail levels and the test durations required are typically set in other material specific test methods. Users of this practice alone may use the known performance of the controls to set test end points. Another option is to continue the test until all specimens have failed, and use the time to reach failure as a way to differentiate performance.

4.3 Results obtained from the use of 100 % humidity tests in accordance with this practice should not be represented as being equivalent to a period of exposure to water in the natural environment, until the degree of quantitative correlation has been established for the coating or coating system.

4.4 The test chamber can be a small laboratory cabinet or a room large enough to hold an automobile or a truck. Some automobile manufacturers test completed vehicles in rooms maintained at 100 % relative humidity. Corrosion tests can be conducted, as the condensate dripping off the test articles is not recirculated.

5. Apparatus

5.1 *Test Chamber*, constructed of corrosion-resistant materials with supports for the test specimens.

5.2 *Source of Heated Water Vapor* can be created by one of the following methods:

5.2.1 *Heated Water Tank*, within the test chamber, a water supply, and a water level control.

5.2.2 *Water Vapor (Steam) Generator*, located outside the test chamber, a water supply, and a means of introducing the vapor to the test chamber.

5.3 *Thermostatic Control*, for the water heater with the sensor located adjacent to the specimen holders, or a means of controlling volume of steam.

5.4 *Thermometer*, with sensor located adjacent to the specimen holders.

5.5 Diagrams and details of the apparatus are shown in Appendix X1.

6. Test Specimens

6.1 This practice does not cover the preparation of test specimens. The substrate composition and surface preparation, specimen preparation, and the number of specimens should be agreed upon prior to testing.

NOTE 2—Applicable methods for the preparation of test panels and substrates are given in Practices D609 and D1730. Practices D823 cover application techniques for the production of uniform films.

6.2 It is recommended that a control specimen of a coating with known durability and similar failure type be included with each test. Such control specimens can provide warning of changes in test severity in a given apparatus, and can indicate variations in test severity between different apparatuses. Best practice is to use two different control specimens, one with known relatively poor performance, and one with known relatively good performance. The use of control specimens with known performance can also be used to determine the duration of the test that is required to produce meaningful results.

6.3 It is recommended that at least two replicate specimens of each different coating be used, so as to compensate for variations between specimens and potential variations in test conditions with the device. If more than one replicate specimen is exposed, place the replicates in different locations in the exposure area.

7. Procedure

7.1 Generate the saturated water vapor with reagent water conforming to at least the requirements of Type IV of Specification D1193.

7.2 Unless otherwise specified, adjust the temperature of the saturated air and water vapor mixture so that the air temperature next to the test specimens is 38°C. During equilibrium operation, the temperature of the sensor used to measure the air next to the specimens can vary by a maximum of $\pm 2^\circ\text{C}$ from the desired temperature. If a temperature set point different from 38°C is used, it must be included in the Test Report.

7.2.1 The temperature of the water vapor will typically be the same or higher than the air temperature next to the specimens. This is a requirement in order for this procedure to work correctly. The temperature of the water in the vapor generation is not set by this practice but water vapor temperatures that are greater than 38°C tend to make condensation more uniform over the test specimens.

NOTE 3—Due to heat loss to the specimens and the walls of the chamber where a heated water tank is used, the temperature of the water in the tank will be above the temperature of the air and water vapor mixture.

7.3 Support flat specimens approximately 15° from the vertical with the front side facing up. Slotted nonmetallic supports are suitable for flat specimens. Position 3-dimensional specimens on a support so that the primary surface is as close to end-use position as possible. Material used for supports shall be of sufficient stiffness so that they do not distort or sag during prolonged use. The minimum distance between adjacent specimens or between specimens and the walls of the chamber shall be at least 30 mm. Arrange specimens so that condensate from one specimen cannot drip on other specimens.

7.4 Droplets of condensation shall appear evenly on the specimen at all times if the chamber is operating properly. Before using the exposure device to this standard for the first time, verify the exposure area for condensation uniformity in accordance with the procedure described in Annex A1. Re-verify the chamber if there are any changes to the setup of the equipment or if any of the components listed in Section 5 are repaired or replaced. Operate the test continuously with the test chamber closed unless otherwise specified. Short interruptions to inspect or remove specimens are permitted, but such interruptions should occur no more than once each day.

7.5 To control for variability within the apparatus, reposition the specimens on a regular basis so that all specimens spend equivalent amounts of time in the various areas of the apparatus (front, back, left, right, and center).

7.6 Conclude the test after a specified period of time or after effects from exposure to water are observed.

7.7 Wipe the test specimens dry. Rate specimens for changes in color, blistering, etc. Evaluate specimens no less than 5 min and no more than 10 min after removal from test, as the effects from water exposure can change within a short time. Remove only as many specimens as can be rated within the specified time.

NOTE 4—Relevant procedures for evaluating water effects are described in Practice D610 and Test Methods D714, D1654, D2616, D3359, D3363, D4541.

7.7.1 If possible, rate the specimens again after they have been removed from the test for a recovery period long enough that moisture absorbed within the specimens dries out and the specimens reach moisture equilibrium with room air. A recovery period from 12 to 24 h is generally sufficient. The post-recovery rating allows evaluation of the permanent effects of the exposure as distinct from the transient effects, and is especially important for evaluation of color and gloss.

8. Report

8.1 Report the following information:

8.1.1 Sample identification.

8.1.2 Results of the evaluation(s).

8.1.3 Reference to Practice D2247.

8.1.4 Hours of test duration.

8.1.5 Test temperature.

8.1.6 Special conditions of test or any deviations in test procedure.

9. Keywords

9.1 adhesion; blistering; humidity; resistance-water; rust

ANNEX

(Mandatory Information)

A1. VERIFICATION

A1.1 *Chamber Verification Procedure*—Place at least 17 specimens throughout the planned exposure area with one at the center and four each uniformly distributed in each quadrant of the planned exposure area. Fig. A1.1 is a diagram of placement of specimens for chamber verification. After the specimens have been in an unopened chamber for at least 12 h, open the chamber and check for the presence of uniform condensation on each specimen. Specimens used for chamber

verification shall be at least as tall as the tallest specimens evaluated in normal testing. The minimum distance between specimens used for chamber verification and the wall of the chamber shall be 75 mm. The minimum distance between adjacent test specimens shall be 150 mm. If any specimen does not have condensation, or the condensation is present on only part of the specimen surface, the area within ± 100 mm (4 in.) of the specimen position shall not be used for testing.

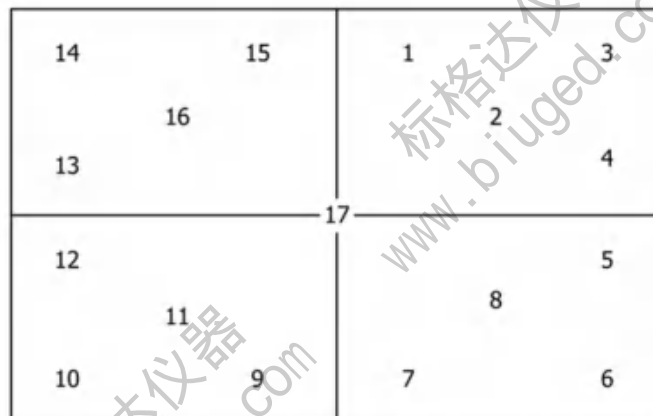

FIG. A1.1 Diagram of Specimen Placement for Mapping Chamber for Condensation Uniformity

APPENDIX

(Nonmandatory Information)

X1. APPARATUS

X1.1 The apparatus must be constructed so that heated water vapor is generated or introduced at the bottom of the chamber. This saturates the air in the lower portion of the test chamber with water vapor. The saturated mixture of water vapor and air temperature rises and then cools below the dew point, causing condensation on the specimens. Three types of apparatus have been found to meet the requirements of this practice. One type uses a water tank with an electric immersion heater, another uses a water vapor generator, and the third type uses a submerged air distribution pipe.

X1.2 In chambers using a water tank with electric immersion heater to supply heat and humidity, the area of the heated water tank should be limited to no more than 25 % of the floor area of the chamber. The use of a large heated water tank would tend to make the temperature within the chamber uniform, and thus inhibit or prevent the formation of condensate on the specimens. The water temperature will be approximately from 5 to 10°C (40 to 20°F) above the vapor temperature when the water tank and chamber are properly proportioned.

X1.3 In chambers using a water jacket to supply heat and humidifying tower (optional) and submerged air distribution pipe to supply humidity, the water level in the chamber should be approximately 15 cm (6 in.) above the bottom of the chamber. The level of water in the heating jacket should be approximately 30 cm (12 in.) above the bottom of the chamber. Specimens must be placed at a level above the water in the heating jacket to insure proper condensation. Air pressure to the humidifying tower should be approximately 7 to 14 kPa (1 to 2 psi).

X1.4 Insulation of the test chamber is not required and can possibly interfere with the formation of condensate by reducing the temperature differential within the chamber. It is difficult to produce condensation with small chambers because the temperature differential is too slight.

X1.5 Large walk-in chambers may require more than one heated water tank to generate the convective currents needed to cause condensation at all points within the chamber. Circulating fans should be used with caution as their use may reduce the temperature differential and limit condensation.

X1.6 In a properly operating chamber, condensation is observed on the specimens or parts when the chamber is opened for inspections. If condensation is not observed on any specimen immediately after the chamber is opened, discontinue the test and determine the cause of the lack of condensation before continuing. Report any instances of condensation non-uniformity if they occur during the exposure. It may be necessary to avoid placing specimens in the lower portion of the chamber as the temperature differentials at the lower levels may be too small to induce condensation.

X1.7 In the event that enough condensation does not occur, or condensation does not form at all the desired points, it is possible to increase condensation by turning off the water heater periodically to cause temperature fluctuations.

X1.8 Many variations in the design of the apparatus are possible in the use of this practice. Four typical designs are shown in Fig. X1.1, Fig. X1.2, Fig. X1.3, and Fig. X1.4.

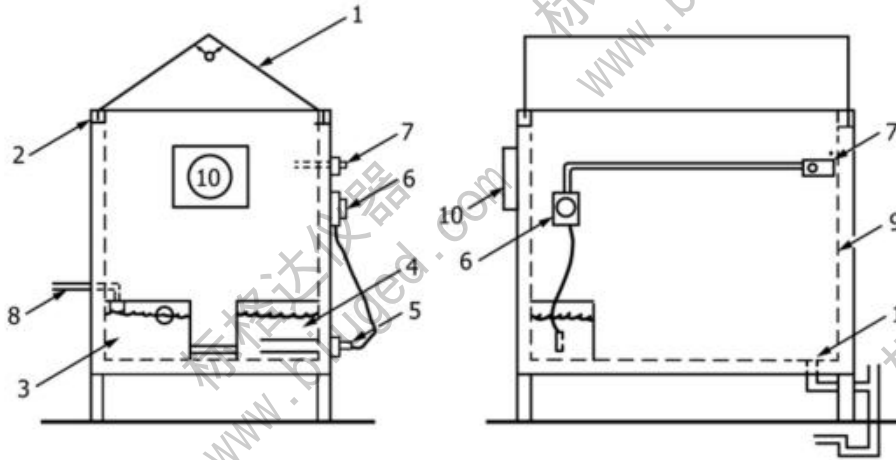

- 0—Angle of lid, 90 to 125°
- 1—Hinged top, hydraulically operated, or counterbalanced
- 2—Water seal
- 3—Constant-level water tank unheated with overflow outlet and equalizer connection
- 4—Heater water tank for supplying heat and humidity to cabinet
- 5—Immersion heater
- 6—Water temperature limit control
- 7—Thermostatic controller for room temperature. Primary limit control for immersion heater (5)
- 8—Water line
- 9—Insulation if necessary (see X1.3)
- 10—Temperature recorder (optional)
- 11—Drain

FIG. X1.1 Humidity Cabinet

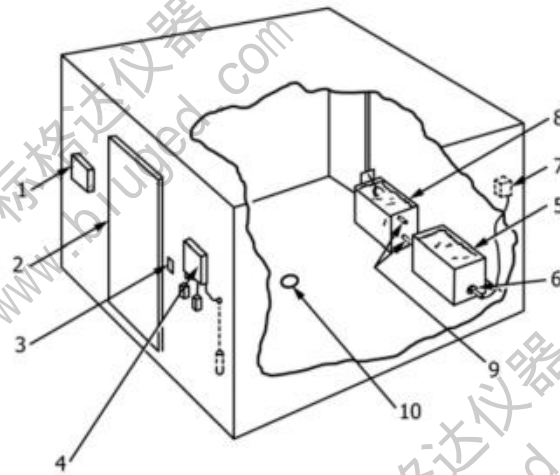

- 1—Temperature recorder
- 2—Fiberglass door with magnetic closers and rubber seal; inward sloping sill
- 3—Light switch
- 4—Thermostatic controller for room temperature. Primary limit control for immersion heater (6)
- 5—Heated water tank for supplying heat and humidity to room
- 6—Immersion heater
- 7—Water temperature limit control
- 8—Constant level water tank unheated with overflow outlet
- 9—Equalizer connection
- 10—Floor drain

NOTE 1—The chamber shall feature waterproof construction with insulation and vapor proof fixtures on the interior, lighting may be accomplished with a fluorescent fixture above insulating glass sealed in the ceiling. Polyvinyl chloride pipe and flanges shall be used for sleeves through walls.

FIG. X1.2 Walk-in Humidity Chamber

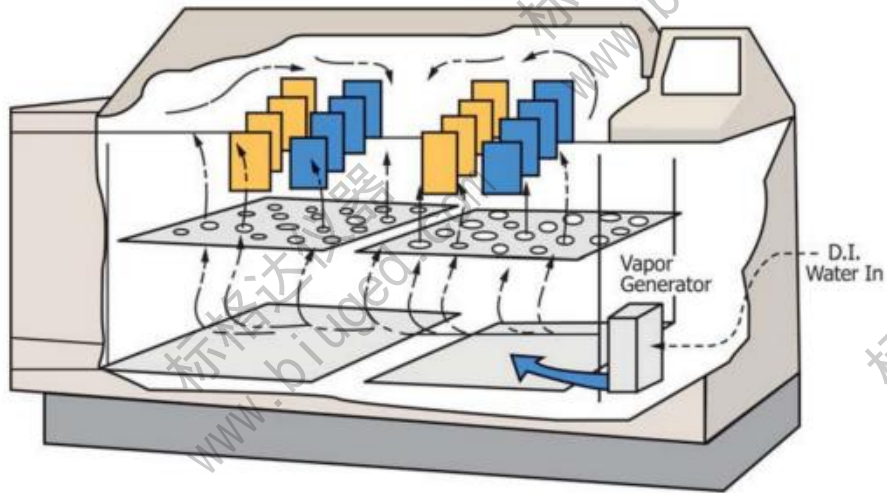

- 1—Water vapor generated as steam outside the chamber
- 2—Water vapor introduced to bottom portion of chamber
- 3—Air inside the chamber is heated by plates inside the chamber and located in lower portion
- 4—Chamber walls are not insulated
- 5—Temperature of air is controlled next to the specimens
- 6—Warm saturated water vapor rises and forms condensation in the slightly cooler top portion of the chamber

FIG. X1.3 Cyclic Corrosion Tester Cabinet with Vapor Generator

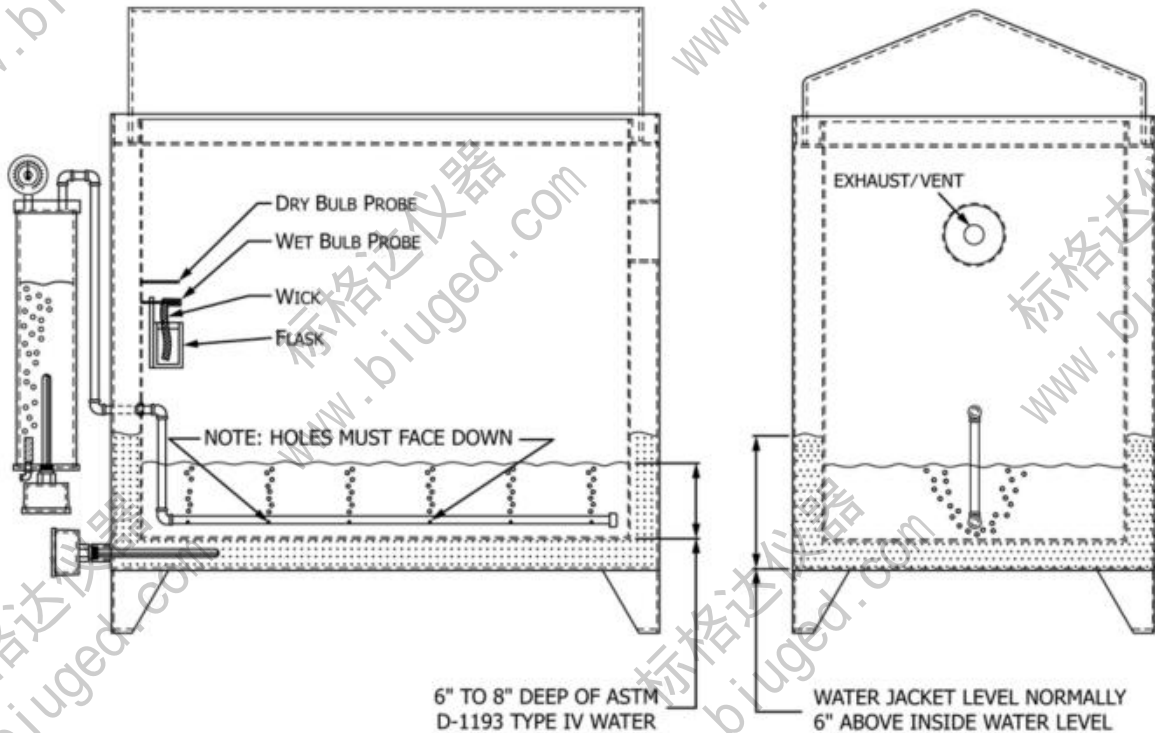

6" TO 8" DEEP OF ASTM D-1193 TYPE IV WATER
 FIG. X1.4 Humidity Cabinet



D2247 – 15

SUMMARY OF CHANGES

Committee D01 has identified the location of selected changes to this standard since the last issue (D2247-11) that should not impact the use of this standard. (Approved December 1, 2015.)

- (1) Minor revisions to 7.2.1, Note 3, to increase clarity. (2) Revised A.1 to correct “is” to “shall be.”

ASTM International takes no position respecting the validity of any patent rights asserted in connection with any item mentioned in this standard. Users of this standard are expressly advised that determination of the validity of any such patent rights, and the risk of infringement of such rights, are entirely their own responsibility.

This standard is subject to revision at any time by the responsible technical committee and must be reviewed every five years and if not revised, either reapproved or withdrawn. Your comments are invited either for revision of this standard or for additional standards and should be addressed to ASTM International Headquarters. Your comments will receive careful consideration at a meeting of the responsible technical committee, which you may attend. If you feel that your comments have not received a fair hearing you should make your views known to the ASTM Committee on Standards, at the address shown below.

This standard is copyrighted by ASTM International, 100 Barr Harbor Drive, PO Box C700, West Conshohocken, PA 19428-2959, United States. Individual reprints (single or multiple copies) of this standard may be obtained by contacting ASTM at the above address or at 610-832-9585 (phone), 610-832-9555 (fax), or service@astm.org (e-mail); or through the ASTM website (www.astm.org). Permission rights to photocopy the standard may also be secured from the Copyright Clearance Center, 222 Rosewood Drive, Danvers, MA 01923, Tel: (978) 646-2600; http://www.copyright.com/