



Designation: D4828 – 94 (Reapproved 2016)

Standard Test Methods for Practical Washability of Organic Coatings¹

This standard is issued under the fixed designation D4828; the number immediately following the designation indicates the year of original adoption or, in the case of revision, the year of last revision. A number in parentheses indicates the year of last reapproval. A superscript epsilon (ϵ) indicates an editorial change since the last revision or reapproval.

1. Scope

1.1 These test methods cover the determination of the relative ease of removal of common soil and stains from interior coatings by manual or mechanical washing with a sponge and a liquid or powder cleanser.

1.2 The values stated in SI units are to be regarded as the standard. The values given in parentheses are for information only.

1.3 *This standard does not purport to address all of the safety concerns, if any, associated with its use. It is the responsibility of the user of this standard to establish appropriate safety and health practices and determine the applicability of regulatory limitations prior to use.*

2. Referenced Documents

2.1 *ASTM Standards:*²

D1193 Specification for Reagent Water

D3450 Test Method for Washability Properties of Interior Architectural Coatings

D3924 Specification for Environment for Conditioning and Testing Paint, Varnish, Lacquer, and Related Materials (Withdrawn 2016)³

3. Summary of Test Method

3.1 The test material is applied to a plastic panel and allowed to dry for 7 days or as mutually agreed. Soilants or stains, or both, are applied to the film. The film is washed for up to 100 cycles using a sponge and a liquid or powder cleanser. After rinsing and drying, the panel is evaluated for the degree of soil or stain removal, erosion, and any change in gloss/sheen or color between the washed and unwashed area.

¹ These test methods are under the jurisdiction of ASTM Committee D01 on Paint and Related Coatings, Materials, and Applications and are the direct responsibility of Subcommittee D01.42 on Architectural Coatings.

Current edition approved Dec. 1, 2016. Published December 2016. Originally approved in 1988. Last previous edition approved in 2012 as D4828 – 94 (2012)¹. DOI: 10.1520/D4828-94R16.

² For referenced ASTM standards, visit the ASTM website, www.astm.org, or contact ASTM Customer Service at service@astm.org. For *Annual Book of ASTM Standards* volume information, refer to the standard's Document Summary page on the ASTM website.

³ The last approved version of this historical standard is referenced on www.astm.org.

4. Significance and Use

4.1 Interior architectural paints are subjected in use to soiling by dirt or other stains. This test method provides a way to assess relative ease of soil or stain removal from a paint film using materials common to households. This test method includes a way to evaluate the film for washability properties and changes in appearance. Thus, a formulator may evaluate the effects of composition on the washability properties of a paint. Users may compare the ease of soil removal from different paints that are tested, preferably at the same time.

5. Apparatus

5.1 *Sponge and Holder.*

5.2 *Soil and Stain Applicator* (see Fig. 1).

5.3 *Weight*, 100 g.

5.4 *Balance*, weighing accurately to 0.1 g.

5.5 *Wet Film Applicator*, capable of applying a wet film of 0.9 mm (3.5 mil) thick by 150 mm (6 in.) film width.

5.6 *Glass Plate*, 455 by 165 mm by 6.3 mm (17½ by 6½ by ¼ in.).

5.7 *Washability Machine.*

5.8 *Black Plastic Panels.*

5.9 *Masking Tape.*

5.10 *Straightedge*, approximately 430 mm (17 in.) in length.

5.11 *Cotton Tipped Swabs.*

5.12 *Medicine Droppers.*

5.13 *Suction Plate*, for drawdowns.

6. Reagents and Materials

6.1 *Purity of Water*—Unless otherwise indicated, references to water shall be understood to mean reagent water as defined by Type IV of Specification D1193.

6.2 *Soil and Staining Medium*—Examples found acceptable for use with this test method include, but are not limited to pencil, crayon, mercurchrome, ball-point pen, waterborne felt-tip markers, lipstick and mineral-oil-borne soilant as outlined in Test Method D3450.

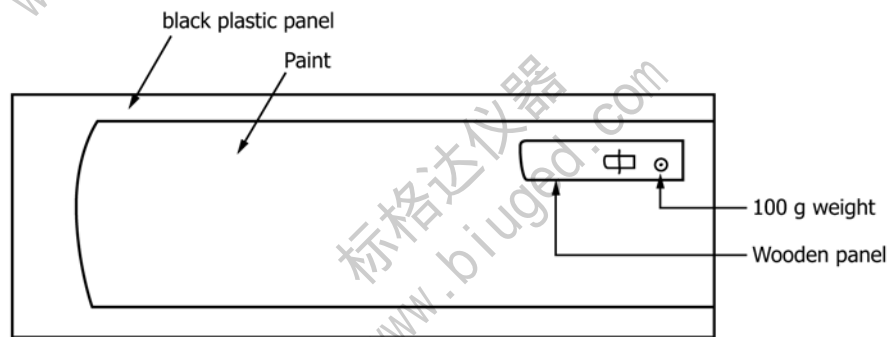
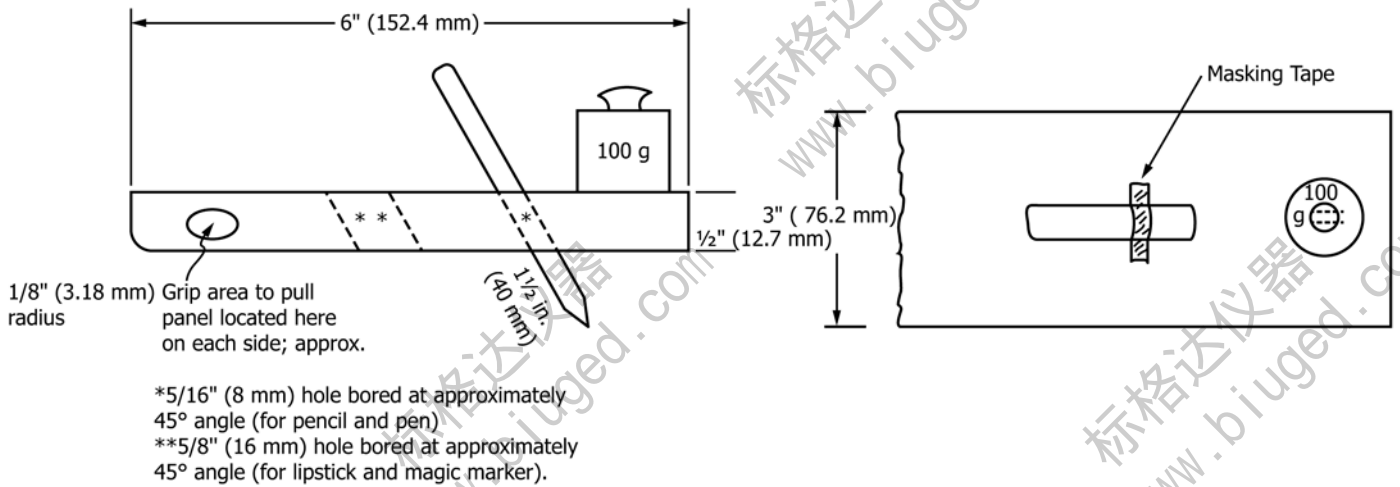

FIG. 1 Solid Soil and Stain Application

6.3 *Cleaning Media*—Examples found acceptable for use with this test method include, but are not limited to, commercial liquid cleansers, laboratory-standardized liquid cleaners as outlined in Test Method D3450, and powder cleansers. Powder cleansers containing chlorine may affect the color of the washed portion of the test panel.

7. Preparation of Apparatus

7.1 *Washability Machine*—Level the apparatus before use and operate at 37 ± 1 cpm. (A cycle consists of a complete forward and reverse stroke.)

7.2 *Sponge and Holder*—Add sufficient weight to the holder in the form of metal sheets or other flat weights to give a combined weight of 1000 g, including the dry sponge.

NOTE 1—Check the compression of the damp sponge under the 1000-g weight to ensure that the holder does not drag along the panel and tear the film.

8. Procedure

8.1 Clean the top of the glass plate and both sides of the black plastic panel to be sure they are free of specks. Place the black panel on the glass plate and tape one end to the plate. Smooth the panel along the plate to ensure a close fit.

8.2 Stir the material thoroughly and strain, if necessary, to remove all skins and particles. Draw down the coating on the panel. Apply the coating in 3 to 4 s from end to end to prevent pin holes or holidays in the film. Prepare enough panels with

each paint for all the projected tests. Air dry all panels in a horizontal position for 7 days in a room maintained at $23 \pm 2^\circ\text{C}$ ($73 \pm 3.5^\circ\text{F}$) and $50 \pm 5\%$ relative humidity as described in Specification D3924, or under conditions specifically applicable to the material under test.

NOTE 2—If desired, an extra panel of each paint may be prepared to serve as its unwashed control.

8.3 Application of Soilants and Stains:

8.3.1 At the completion of the drying period, tape the coated panel to the glass plate, as directed in 8.1, to ensure uniform application of the soilants and stains. Apply the selected soilants or stains, or both, to the coating film in straight pairs of lines parallel to the length of the panel for the manual method of cleaning, or perpendicular to the length of the panel for the mechanical method of cleaning.

8.3.2 Apply solid soilants or stains using the apparatus shown in Fig. 1. Insert pencil, crayon, pen, or similar items into the appropriately sized hole and secure its position so it extends 40 mm (1½ in.) beyond the panel (see Fig. 1(a)). Secure the medium in position with a piece of masking tape (see Fig. 1(b)). Put the applicator at one end of the coated plastic panel and place the 100-g weight on the top face of the wooden panel at the end nearest to the marking device, as shown in Fig. 1(b), securing it with a piece of tape. Allow the nonweighted end of the applicator to rest on the surface of the film, then hold it by the outer edges and pull it along the entire length of the film (see Fig. 1(c)).

NOTE 3—Some soils and stains are prone to smearing. It is advisable to apply them last to the film and protect the first lines with materials such as wax paper or onionskin paper when applying the second and subsequent lines.

8.3.3 Apply liquid stains using hand-held cotton-tipped swabs. Immerse one end of a cotton-tipped swab in an appropriate liquid and allow to remain totally immersed until the cotton tip is saturated (approximately 10 to 15 s). Remove the tip from the liquid and apply the first of two parallel lines to the paint film using the straightedge to assist in drawing the lines. Adjustment of pressure on the cotton tip may be required to provide a line of uniform intensity. Reimmerse the cotton tip in the liquid and then draw the second line. Repeat with a clean cotton tip for each liquid being used. Permit the soilants and stains to dry at least 1 h under the same temperature and humidity conditions as in 8.2.

8.4 *Washing with a Liquid Cleanser:*

8.4.1 Soak the sponge in tap water at ambient temperature until saturated. Remove the sponge and squeeze with one hand until no more water drips from the sponge. Replace the sponge in the holder and pour 15 ± 1 mL of water on the exposed face of the sponge.

8.4.2 Measure and deliver to the exposed face of the sponge 5 mL of the liquid cleaning medium. Apply 2 mL of liquid cleaning medium in parallel bands to each soilant and stain line.

8.5 *Washing with a Powder Cleanser:*

8.5.1 Use a separate sponge prepared in accordance with 8.4.1. (Alternatively, thoroughly wash the sponge used until all traces of the liquid cleanser are removed and repeat 8.4.1.)

8.5.2 Weigh 2 g of the powder cleanser and deliver to the exposed face of the sponge. Use a spatula to spread the cleanser until it appears to be wetted by the moisture left in the sponge. Apply 5 mL of water in parallel bands to each soilant and stain line.

8.6 *Manual Method:*

8.6.1 Place the sponge and holder at one end of the panel so that its long axis is *perpendicular* to the length of the panel (see Fig. 2). Rub the sponge across the panel over the soil or stain lines, exerting minimum downward pressure. Continue rubbing until all the soils or stains are removed or to a maximum of 100 cycles. If all the soils or stains are removed prior to 100 cycles, stop and record the number of cycles before proceeding to 8.8.

8.7 *Mechanical Method:*

8.7.1 Place the sponge and holder at one end of the panel so that its long axis is *parallel* to the length of the panel (see Fig. 2). Attach to the cable of the washability machine. Allow the sponge to travel a maximum of 100 cycles. If all the soils or stains are removed prior to 100 cycles, stop and record the number of cycles before proceeding to 8.8.

8.8 Remove the test panel and evaluate the condition of each soil or stain in the path of the sponge and rate as follows:

- 0—No change from original intensity (depth) of soil or stain,
- 3—Slight change from original, but readily visible,
- 5—Moderate change from original, slightly visible,
- 7—Large change from original, barely visible, and
- 10—All soil and stain removed.

If a difference exists between a pair of lines, report the lower rating of the pair. When a soil or stain is removed prior to 100 cycles, assign a rating of 10 and note the number of cycles in which each soilant or stain was removed.

8.9 Rinse the panel with running tap water and remove any clinging particles of cleaning medium by gently moving the palm of the hand over the path the sponge followed during the washing cycle. Blot the panel and allow to dry. Rate the washed area relative to the unwashed areas for gloss or color change and erosion as given below:

Gloss Change	Color Change	Erosion
N—None	N—None	N—None
I—Increase	SD—Slightly darker	S—Slight
II—Large increase	CD—Considerably darker	M—Moderate
D—Decrease	SL—Slightly lighter	
DD—Large decrease	CL—Considerably lighter	

9. Report

9.1 Report the following information:

9.1.1 Types of soilant, stain, washing media, the washing method used, and the results obtained in 8.8 and 8.9,

9.1.2 Any soils or stains that were removed in less than 100 cycles, and

9.1.3 Any deviation from the recommended procedure.

10. Precision and Bias⁴

10.1 *Precision:*

10.1.1 *Mechanical Procedure*—In an interlaboratory study of this test method, operators in each of four laboratories applied three types of markings to two panels of each of three coatings covering a wide range of PVCs and evaluated the removability using an abrasive cleaner. The intralaboratory standard deviation was found to be 5.1 cycles with 13 df and the interlaboratory standard deviation is 10.5 cycles with 19 df. Based upon these standard deviations, the following criteria should be used for judging, at the 95 % confidence level, the acceptability of results:

10.1.1.1 *Repeatability*—Two results obtained by the same operator on different panels should be considered suspect if they differ by more than 15.5 cycles.

10.1.1.2 *Reproducibility*—Two results, each the mean of tests on two panels, obtained by operators in different laboratories should be considered suspect if they differ by more than 28.5 cycles.

10.2 *Bias*—This procedure has no bias because the value is defined only in terms of this test method.

11. Keywords

11.1 cleansability; soil/dirt resistance; stain resistance; washability; wet abrasion resistance

⁴ Supporting data have been filed at ASTM International Headquarters and may be obtained by requesting Research Report RR:D01-1052. Contact ASTM Customer Service at service@astm.org.

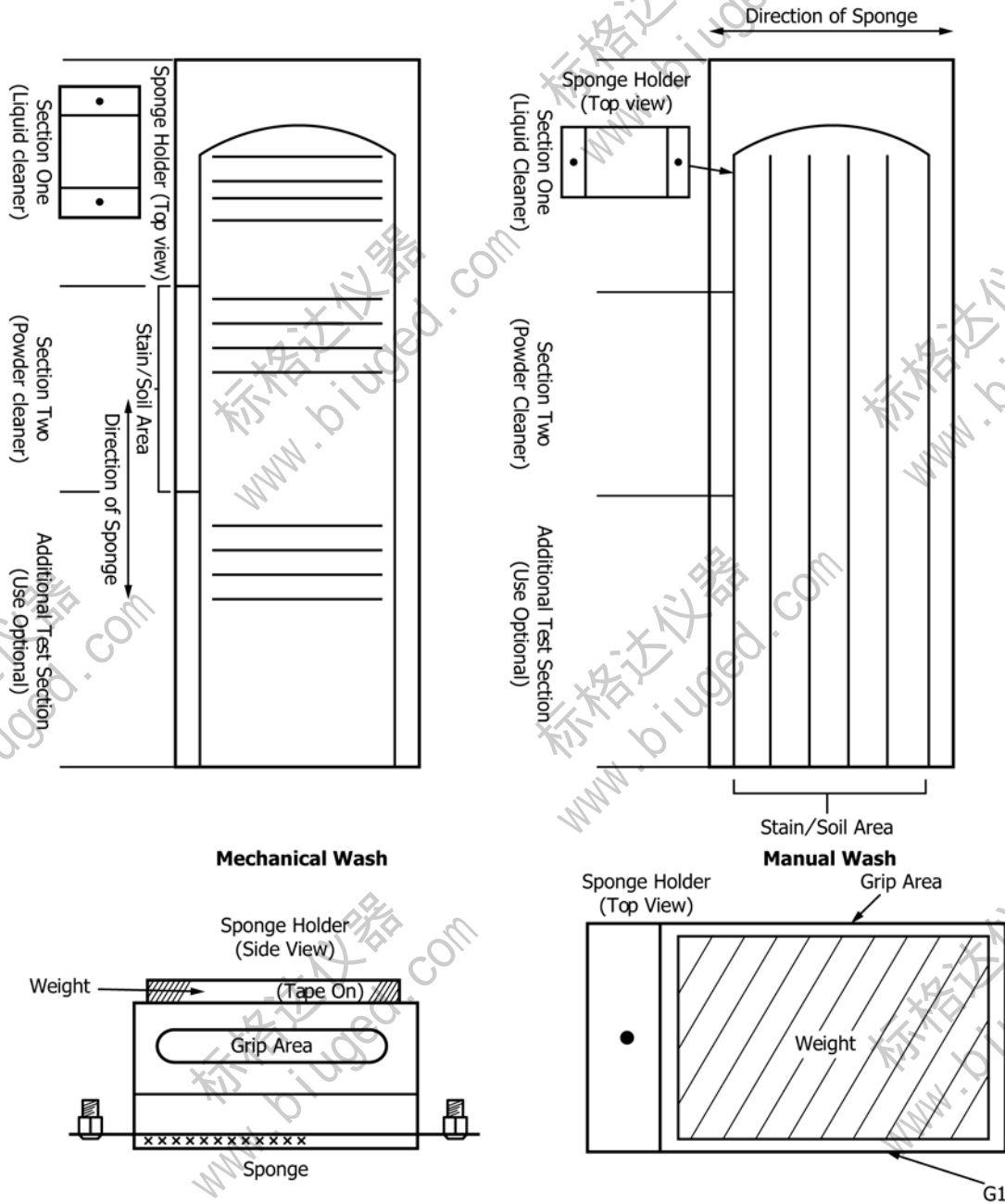

FIG. 2 Panel Layout and Brush Holder Diagram

ASTM International takes no position respecting the validity of any patent rights asserted in connection with any item mentioned in this standard. Users of this standard are expressly advised that determination of the validity of any such patent rights, and the risk of infringement of such rights, are entirely their own responsibility.

This standard is subject to revision at any time by the responsible technical committee and must be reviewed every five years and if not revised, either reapproved or withdrawn. Your comments are invited either for revision of this standard or for additional standards and should be addressed to ASTM International Headquarters. Your comments will receive careful consideration at a meeting of the responsible technical committee, which you may attend. If you feel that your comments have not received a fair hearing you should make your views known to the ASTM Committee on Standards, at the address shown below.

This standard is copyrighted by ASTM International, 100 Barr Harbor Drive, PO Box C700, West Conshohocken, PA 19428-2959, United States. Individual reprints (single or multiple copies) of this standard may be obtained by contacting ASTM at the above address or at 610-832-9585 (phone), 610-832-9555 (fax), or service@astm.org (e-mail); or through the ASTM website (www.astm.org). Permission rights to photocopy the standard may also be secured from the Copyright Clearance Center, 222 Rosewood Drive, Danvers, MA 01923, Tel: (978) 646-2600; http://www.copyright.com/