

DRAFT INTERNATIONAL STANDARD

ISO/DIS 2409

ISO/TC 35/SC 9

Secretariat: **BSI**

Voting begins on:
2019-09-05

Voting terminates on:
2019-11-28

Paints and varnishes — Cross-cut test

Peintures et vernis — Essai de quadrillage

ICS: 87.040

THIS DOCUMENT IS A DRAFT CIRCULATED FOR COMMENT AND APPROVAL. IT IS THEREFORE SUBJECT TO CHANGE AND MAY NOT BE REFERRED TO AS AN INTERNATIONAL STANDARD UNTIL PUBLISHED AS SUCH.

IN ADDITION TO THEIR EVALUATION AS BEING ACCEPTABLE FOR INDUSTRIAL, TECHNOLOGICAL, COMMERCIAL AND USER PURPOSES, DRAFT INTERNATIONAL STANDARDS MAY ON OCCASION HAVE TO BE CONSIDERED IN THE LIGHT OF THEIR POTENTIAL TO BECOME STANDARDS TO WHICH REFERENCE MAY BE MADE IN NATIONAL REGULATIONS.

RECIPIENTS OF THIS DRAFT ARE INVITED TO SUBMIT, WITH THEIR COMMENTS, NOTIFICATION OF ANY RELEVANT PATENT RIGHTS OF WHICH THEY ARE AWARE AND TO PROVIDE SUPPORTING DOCUMENTATION.

This document is circulated as received from the committee secretariat.

ISO/CEN PARALLEL PROCESSING



Reference number
ISO/DIS 2409:2019(E)

© ISO 2019

标格达仪器
www.biuged.com

标格达仪器
www.biuged.com

标格达仪器
www.biuged.com

标格达仪器
www.biuged.com

标格达仪器
www.biuged.com

www.biuged.com

标格达仪器
www.biuged.com

标格达仪器
www.biuged.com



COPYRIGHT PROTECTED DOCUMENT

© ISO 2019

All rights reserved. Unless otherwise specified, or required in the context of its implementation, no part of this publication may be reproduced or utilized otherwise in any form or by any means, electronic or mechanical, including photocopying, or posting on the internet or an intranet, without prior written permission. Permission can be requested from either ISO at the address below or ISO's member body in the country of the requester.

ISO copyright office
CP 401 • Ch. de Blandonnet 8
CH-1214 Vernier, Geneva
Phone: +41 22 749 01 11
Fax: +41 22 749 09 47
Email: copyright@iso.org
Website: www.iso.org

Published in Switzerland

标格达仪器
www.biuged.com

标格达仪器
www.biuged.com

Contents

Page

Foreword	iv
1 Scope	1
2 Normative references	1
3 Terms and definitions	1
4 Principle	2
5 Apparatus	2
5.1 General.....	2
5.2 Cutting tool.....	2
5.2.1 General requirements.....	2
5.2.2 Single-blade cutting tools.....	2
5.2.3 Multi-blade cutting tools.....	2
5.3 Guiding and spacing edges.....	5
5.4 Viewing lens.....	5
6 Sampling	6
7 Test specimen	7
7.1 Substrate.....	7
7.2 Thickness of coating.....	7
8 Procedure	7
8.1 General.....	7
8.1.1 Test conditions and number of tests.....	7
8.1.2 Conditioning of the test panels.....	7
8.1.3 Number of cuts.....	7
8.1.4 Spacing of cuts.....	7
8.1.5 Number of determinations.....	8
8.2 Cutting the coating using the manual procedure.....	8
8.3 Cutting the coating using a motor-driven tool.....	8
9 Evaluation and expression of results	8
10 Designation of the test result	9
11 Precision	10
11.1 Repeatability limit, <i>r</i>	10
11.2 Reproducibility limit, <i>R</i>	10
12 Test report	11
Annex A (informative) Examples of suitable procedures for removing loose paint	12
Bibliography	14

Foreword

ISO (the International Organization for Standardization) is a worldwide federation of national standards bodies (ISO member bodies). The work of preparing International Standards is normally carried out through ISO technical committees. Each member body interested in a subject for which a technical committee has been established has the right to be represented on that committee. International organizations, governmental and non-governmental, in liaison with ISO, also take part in the work. ISO collaborates closely with the International Electrotechnical Commission (IEC) on all matters of electrotechnical standardization.

The procedures used to develop this document and those intended for its further maintenance are described in the ISO/IEC Directives, Part 1. In particular, the different approval criteria needed for the different types of ISO documents should be noted. This document was drafted in accordance with the editorial rules of the ISO/IEC Directives, Part 2 (see www.iso.org/directives).

Attention is drawn to the possibility that some of the elements of this document may be the subject of patent rights. ISO shall not be held responsible for identifying any or all such patent rights. Details of any patent rights identified during the development of the document will be in the Introduction and/or on the ISO list of patent declarations received (see www.iso.org/patents).

Any trade name used in this document is information given for the convenience of users and does not constitute an endorsement.

For an explanation of the voluntary nature of standards, the meaning of ISO specific terms and expressions related to conformity assessment, as well as information about ISO's adherence to the World Trade Organization (WTO) principles in the Technical Barriers to Trade (TBT), see www.iso.org/iso/foreword.html.

This document was prepared by Technical Committee ISO/TC 35, *Paints and varnishes*, Subcommittee SC 9, *General test methods for paints and varnishes*.

This fifth edition cancels and replaces the fourth edition (ISO 2409:2013), which has been technically revised. The main changes compared to the previous edition are as follows:

- [Clause 3](#) "Terms and definitions" has been added;
- [Clause 4](#) "Principle" has been added;
- The general requirements for the use of single-cutting tools and multi-cutting tools in [5.2.1](#) have been updated;
- References to commercially available cutters have been deleted from [5.2.2.3](#);
- Coating of the test panels has been deleted from [Clause 7](#), because final test specimen are assumed;
- The text has been editorially revised and the normative references have been updated.

Any feedback or questions on this document should be directed to the user's national standards body. A complete listing of these bodies can be found at www.iso.org/members.html.

Paints and varnishes — Cross-cut test

1 Scope

This document specifies a test method for assessing the resistance of paint coatings to separation from substrates when a right-angle lattice pattern is cut into the coating, penetrating through to the substrate. The property determined by this empirical test procedure depends, among other factors, on the adhesion of the coating to either the preceding coat or the substrate. This procedure is not to be regarded, however, as a means of measuring adhesion.

Where a measurement of adhesion is required, the method described in ISO 4624^[1] may be used.

NOTE 1 Although the test is primarily intended for use in the laboratory, the test is also suitable for field testing.

The method described may be used either as a pass/fail test or, where circumstances are appropriate, as a six-step classification test. When applied to a multi-coat system, assessment of the resistance to separation of individual layers of the coating from each other can be made.

The test can be carried out on finished objects and/or on specially prepared test specimens.

Although the method is applicable to paint on hard (e.g. metal) and soft (e.g. wood and plaster) substrates, these different substrates need a different test procedure (see [Clause 6](#)).

The method is not suitable for coatings of total thickness greater than 250 µm or for textured coatings.

NOTE 2 The method, when applied to coatings designed to give a rough patterned surface, will give results which will show too much variation (see also ISO 16276-2^[2]).

2 Normative references

The following documents are referred to in the text in such a way that some or all of their content constitutes requirements of this document. For dated references, only the edition cited applies. For undated references, the latest edition of the referenced document (including any amendments) applies.

ISO 1513, *Paints and varnishes — Examination and preparation of test samples*

ISO 2808, *Paints and varnishes — Determination of film thickness*

ISO 4618, *Paints and varnishes — Terms and definitions*

ISO 13076, *Paints and varnishes — Lighting and procedure for visual assessments of coatings*

ISO 15528, *Paints, varnishes and raw materials for paints and varnishes — Sampling*

3 Terms and definitions

For the purposes of this document, the terms and definitions given in ISO 4618 apply.

ISO and IEC maintain terminological databases for use in standardization at the following addresses:

- ISO Online browsing platform: available at <http://www.iso.org/obp>
- IEC Electropedia: available at <http://www.electropedia.org/>

4 Principle

Six parallel cuts are introduced in the coating and another six cuts are introduced perpendicular to the first cuts. Any loose paint particles are removed. The cut area is examined visually and compared to a six-step classification.

5 Apparatus

5.1 General

Use ordinary laboratory apparatus, together with the apparatus specified in [5.2](#) to [5.4](#).

5.2 Cutting tool

5.2.1 General requirements

It is particularly important to ensure that the cutting tool is capable of creating the specified V-shape throughout the total coating thickness, and that the cutting edges are in good condition. Suitable tools are described in [5.2.2](#) and [5.2.3](#) and shown in [Figures 1](#) and [2](#).

A single-blade cutting tool ([5.2.2](#)) as well as the multi-blade cutting tool ([5.2.3](#)) is suitable for all coatings and substrates; it has to be ensured that all cuts mark or scratch the substrate. The depth of indentation into the substrate shall be as low as possible, however.

The tools described in [5.2.2](#) and [5.2.3](#) are suitable for manual use, which is the more usual method of use, but the tools may also be mounted on a motor-driven apparatus, which gives more uniform cutting. The application of the latter procedure shall be subject to agreement between the interested parties.

The apparatus (manual or motor-driven) and the type of cutting tool used have an influence on the test result. Results obtained with different types of cutting tool cannot be directly compared.

5.2.2 Single-blade cutting tools

5.2.2.1 Hand-held single-blade cutting tool with a cutting edge as shown in [Figure 1a](#)).

5.2.2.2 Single-blade cutting tool used in motor-driven apparatus as shown in [Figure 3](#).

5.2.2.3 Cutter with a rigid blade with a V-shaped cutting edge as shown in [Figure 1b](#)).

The specific thickness of the blade is not specified, as long as the blade is rigid and the cut produced is V-shaped through the whole thickness of the coating.

NOTE The cutter blade is designed to be broken in a defined manner so that a sharp blade is available at any time.

5.2.3 Multi-blade cutting tools

5.2.3.1 Hand-held multi-blade cutting tool with cutting edges as shown in [Figure 2](#).

5.2.3.2 Multi-blade cutting tool used in motor-driven apparatus as shown in [Figure 3](#).

The multi-blade cutting tool shall have six cutting edges spaced 1 mm, 2 mm or 3 mm apart. In addition, two guide edges (see [Figure 2](#)) are necessary to make handling easier. The guide edges and the cutting edges shall lie on the same diameter (see [Figure 2](#)).

Dimensions in millimetres

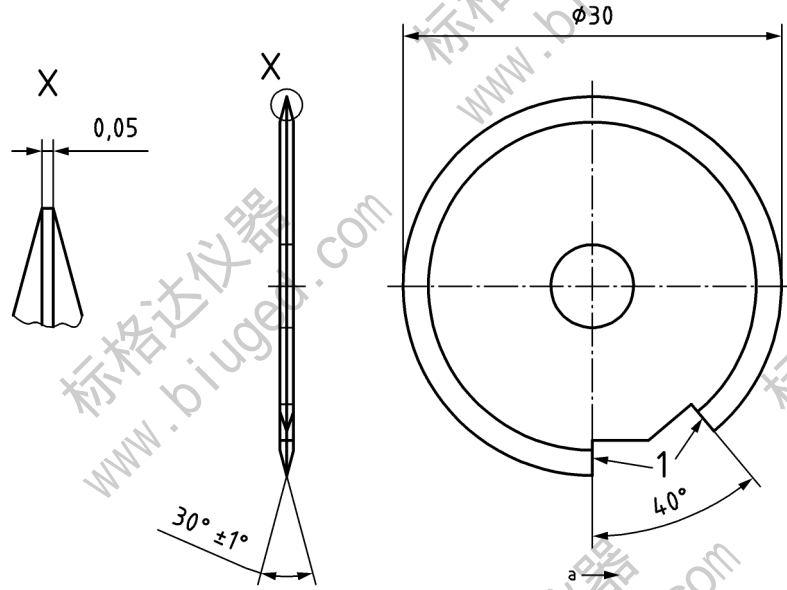

a) Hand-held single-blade cutting tool

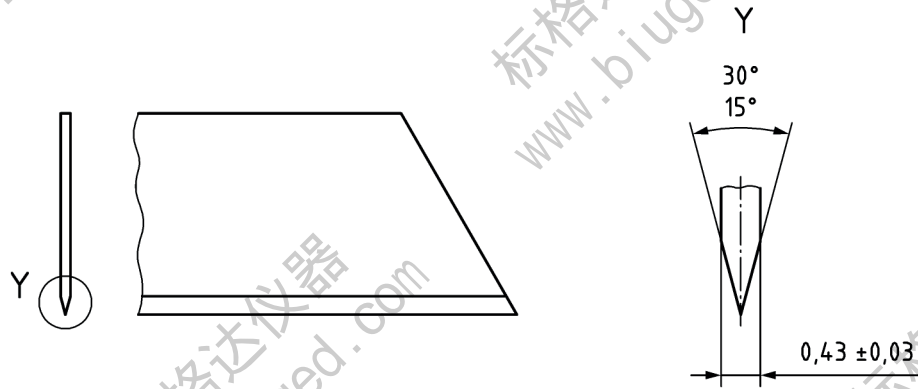

b) Cutter with rigid blade with V-shaped cutting edge (see 5.2.2.3)

Key

- 1 cutting edges
- a Direction of cut.

Figure 1 — Examples of single-blade cutting tools (all dimensions approximate except where tolerances are specifically indicated)

Dimensions in millimetres

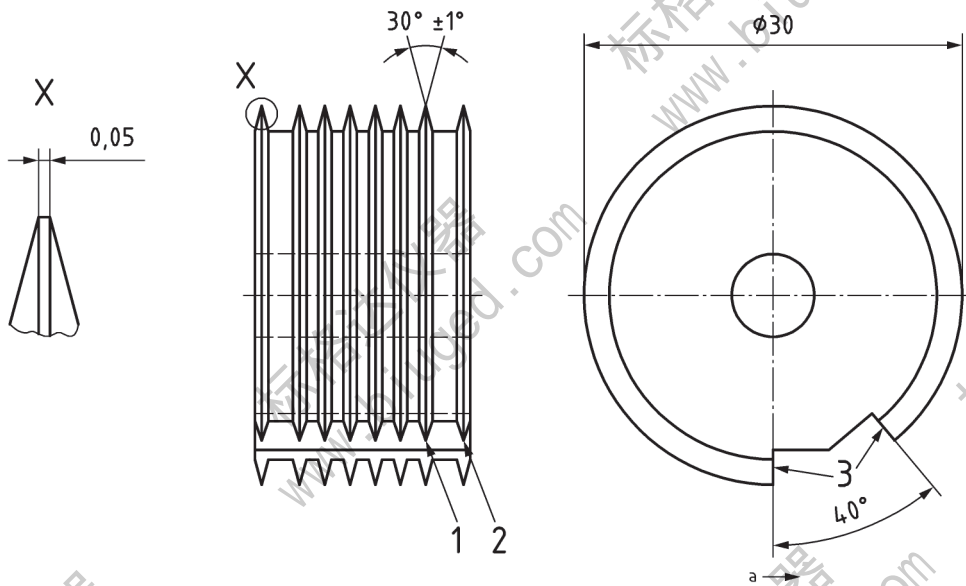

a) Hand-held multi-blade cutting tool

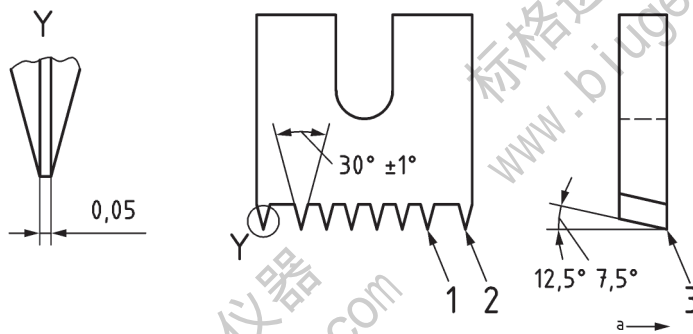

b) Multi-blade cutting tool used in motor-driven apparatus

Key

- 1 cutting blade
- 2 guide edge
- 3 cutting edges
- a Direction of cut.

Figure 2 — Examples of multi-blade cutting tools (all dimensions approximate)

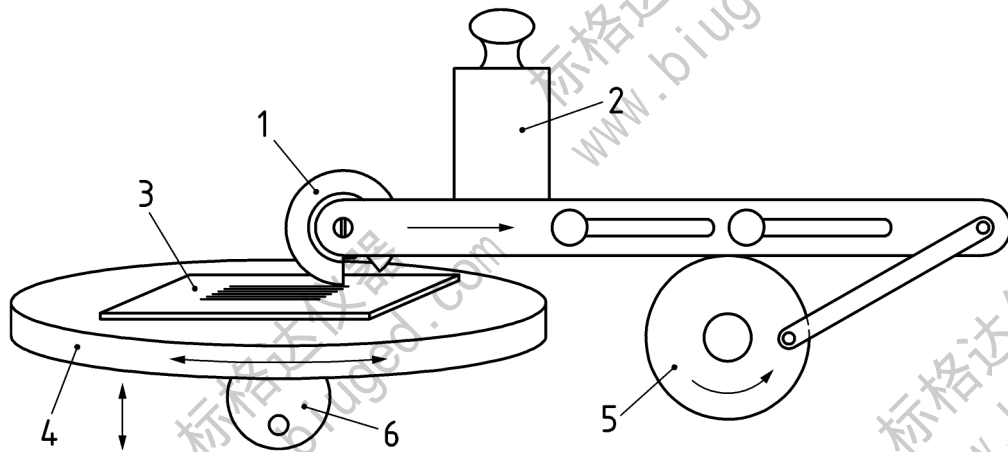
**Key**

- 1 cutting tool
- 2 weight
- 3 test panel
- 4 rotating test panel holder
- 5 motor
- 6 handle for rotating the test panel holder

Figure 3 — Motor-driven apparatus

5.3 Guiding and spacing edges

In order to space the cuts correctly, a series of guiding and spacing edges is necessary when using a single-blade cutting tool.

A folding ruler suitable for use with hand-held single-blade cutting tools (5.2.2.1) is shown in Figure 4a).

A series of guiding edges suitable for use with cutters with a rigid blade with a V-shaped cutting edge (see 5.2.2.3) is shown in Figure 4 b).

5.4 Viewing lens

Use a hand-held lens with a magnification of $\times 2$ or $\times 3$.

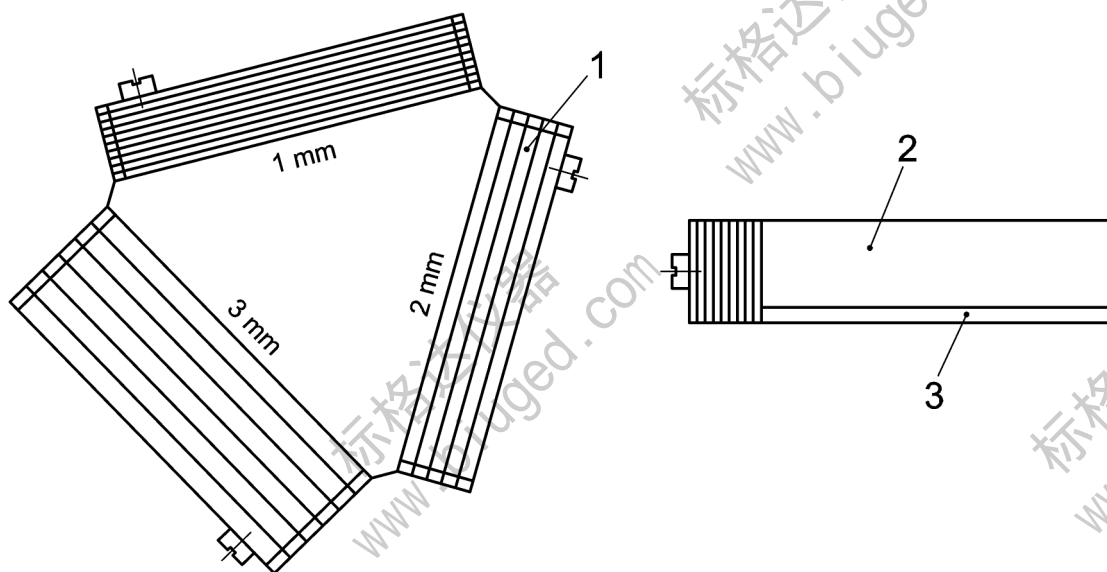

a) Series of spacing edges

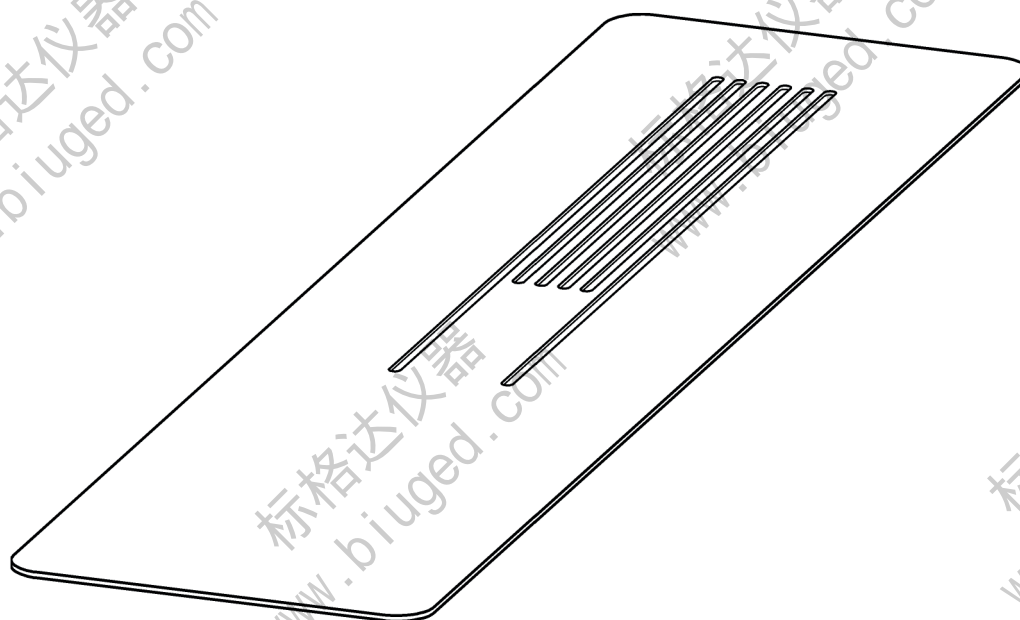

b) Series of guiding edges

Key

- 1 spacing edges for 1 mm, 2 mm and 3 mm cuts
- 2 laminated plastic or steel
- 3 rubber

Figure 4 — Examples of guiding and spacing edges

6 Sampling

Take a representative sample of the product to be tested, as described in ISO 15528.

Examine and prepare each sample for testing, as described in ISO 1513.

7 Test specimen

7.1 Substrate

The test specimen shall be plain and free from distortion, preferably test panels. The dimensions shall be such as to allow the test to be carried out at three different positions not less than 5 mm from each other and from the edge of the panel.

Where panels consist of a relatively soft material such as wood, the minimum thickness shall be 10 mm. Where panels consist of a hard material, the minimum thickness shall be 0,25 mm.

NOTE In cases where the panel is made of wood, the direction and the structure of the grain can influence the test, and a pronounced grain will render the evaluation impossible.

7.2 Thickness of coating

Determine the thickness, in micrometres, of the dried coating by one of the procedures specified in ISO 2808. Make the measurement at, or as near as possible to, the positions at which the cross-cut is to be made. The number of thickness determinations is dependent on the method used.

8 Procedure

8.1 General

8.1.1 Test conditions and number of tests

Carry out the test at a temperature of (23 ± 2) °C and a relative humidity of (50 ± 5) %.

In field tests, the ambient conditions shall apply, but shall be measured and recorded [see [Clause 12](#), item d)].

8.1.2 Conditioning of the test panels

Condition the test panels immediately prior to the test at a temperature of (23 ± 2) °C and a relative humidity of (50 ± 5) % for a minimum of 16 h.

8.1.3 Number of cuts

The number of cuts in each direction of the lattice pattern shall be six.

8.1.4 Spacing of cuts

The spacing of the cuts in each direction shall be equal and shall depend on the thickness of the coating and on the type of substrate as follows:

up to 60 µm:	1 mm spacing, for hard (e.g. metal and plastics) substrates;
up to 60 µm:	2 mm spacing, for soft (e.g. wood and plaster) substrates;
61 µm to 120 µm:	2 mm spacing, for both hard and soft substrates;
121 µm to 250 µm:	3 mm spacing, for both hard and soft substrates.

The cross-cut test is not suitable for coatings of total thicknesses greater than 250 µm.

NOTE For coatings of total thickness greater than 250 µm, the X-cut method described in ISO 16276-2^[2] can be used.

8.1.5 Number of determinations

For routine testing, carry out a single determination.

If a higher precision is required, carry out the test in at least three different places (see 7.1) on the panel. If the results do not match, the differences being more than one classification unit, repeat the test at three other places, if necessary using different panels, and record all the results.

8.2 Cutting the coating using the manual procedure

6.2.1 Place the test panel on a rigid, flat surface to prevent any deformation of the panel during the test.

6.2.2 Before the test, inspect the cutting edge of the blade and maintain its condition by sharpening or replacement.

Perform the cutting manually, following the specified procedure.

If the panel is of wood or similar material, make the cuts at approximately 45° to the direction of the grain.

6.2.3 Hold the cutting tool (5.2) with the blade normal (perpendicular) to the test panel surface. With uniform pressure on the cutting tool and using the appropriate spacing guide (5.3), make six cuts in the coating at a uniform cutting rate by moving the cutting tool in the direction approaching the operator. Each cut shall continue on beyond the outermost of the cuts perpendicular to it for approximately 1 mm to 2 mm to give definite intersection points. All cuts shall mark or scratch the substrate. The depth of indentation into the substrate shall be as low as possible, however. For some substrates, e.g. plastics, there is the risk of tearing and flaking of the coating if the cutting tool penetrates the substrate too deep.

If it is not possible, due to the hardness of the coating, to penetrate to the substrate, the test shall be declared invalid and so reported.

6.2.4 Repeat this operation, making a further six parallel cuts, crossing the original cuts at 90° to them so that a lattice pattern is formed.

6.2.5 Remove any loose paint from the area of cutting. Examples of suitable methods are given in Annex A. The method for removing the loose paint shall be agreed between the interested parties and shall be stated in the test report.

8.3 Cutting the coating using a motor-driven tool

If the cutting tool is used with a motor-driven apparatus, take care that the points described in the manual procedure are observed, particularly with respect to the number and spacing of the cuts and the number of tests. Each cut shall continue on beyond the outermost of the cuts perpendicular to it for approximately 1 mm to 2 mm to give definite intersection points.

Remove any loose paint from the area of cutting. Examples of suitable methods are given in Annex A. The method for removing the loose paint shall be agreed between the interested parties and shall be stated in the test report.

9 Evaluation and expression of results

Carefully examine visually the cut area of the test coating in good lighting as specified in ISO 13076, using normal or corrected vision or, if agreed between the interested parties, using a viewing lens (5.4). During the viewing process, rotate the panel so that the viewing and lighting of the test area are not confined to one direction. Classify the test area in accordance with Table 1, by comparison with the illustrations.

NOTE Additional guidance is given by the descriptions in Table 1.

In [Table 1](#), a six-step classification is given. The first three steps are satisfactory for general purposes and are to be used when a pass/fail assessment is required. Special circumstances might arise, in which case the complete six-step classification will be necessary.

For a multi-coat system, report the interface at which any flaking occurs.

If test results differ, report each test result. In the case of a multi-coat system, report the site of separation (between coats or between coating and substrate).

If delaminated flakes occur, interested parties have to agree on a pass/fail criteria.

10 Designation of the test result

A designation code which may be used to indicate the test result is given below. It shall comprise a reference to this document, a reference to the cutting tool used and the classification achieved. For example:

ISO 2409:2013 — 1a — 2

Number of this document — Cutting tool and method used — Classification

Key for cutting tool and method used:

1 Single-blade cutting tool:

- 1a Hand-held single-blade cutting tool
- 1b Single-blade cutting tool used in motor-driven apparatus
- 1c Cutter with rigid blade with V-shaped cutting edge (see [5.2.2.3](#))



2 Multi-blade cutting tool:

- 2a Hand-held multi-blade cutting tool
- 2b Multi-blade cutting tool used in motor-driven apparatus

Key for the classification of test results:

See [Table 1](#)

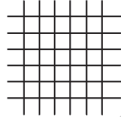
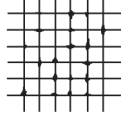
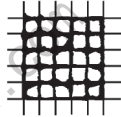
Table 1 — Classification of test results

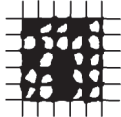
Classification	Description	Appearance of surface of cross-cut area from which flaking has occurred ^a (Example for six parallel cuts)
0	The edges of the cuts are completely smooth; none of the squares of the lattice is detached.	
1	Detachment of small flakes of the coating at the intersections of the cuts. A cross-cut area not greater than 5 % is affected.	
2	The coating has flaked along the edges and/or at the intersections of the cuts. A cross-cut area greater than 5 %, but not greater than 15 %, is affected.	
3	The coating has flaked along the edges of the cuts partly or wholly in large ribbons, and/or it has flaked partly or wholly on different parts of the squares. A cross-cut area greater than 15 %, but not greater than 35 %, is affected.	
4	The coating has flaked along the edges of the cuts in large ribbons and/or some squares have detached partly or wholly. A cross-cut area greater than 35 %, but not greater than 65 %, is affected.	
5	Any degree of flaking that cannot even be classified by classification 4.	—

^a The figures are examples for a cross-cut within each step of the classification. The percentages stated are based on the visual impression given by the pictures and the same percentages will not necessarily be reproduced with digital imaging.

11 Precision

11.1 Repeatability limit, *r*

The repeatability limit *r* is the value below which the absolute difference between two single test results, each the mean of duplicates, can be expected to lie with a 95 % probability when this method is used under repeatability conditions, i.e. when the test results are obtained on identical material by one operator in one laboratory within a short interval of time. For this test method, *r* is 1 classification unit.

11.2 Reproducibility limit, *R*

The reproducibility limit *R* is the value below which the absolute difference between two single test results, each the mean of duplicates, can be expected to lie with a 95 % probability when this method is used under reproducibility conditions, i.e. when the test results are obtained on identical material by operators in different laboratories. For this test method, *R* is 2 classification units.

12 Test report

The test report shall contain at least the following information:

- a) all details necessary to identify the product tested;
- b) a reference to this document, i.e. ISO 2409;
- c) details of the preparation of the test panels, including:
 - 1) the material, the thickness and the surface preparation of the substrate (see [7.1](#)),
 - 2) the method of application of the coating material to the substrate, including the duration and conditions of drying between coats in the case of a multi-coat system (see [7.2](#)),
 - 3) the duration and conditions of drying (or stoving) and ageing (if applicable) of the coating before testing (see [7.3](#)),
 - 4) the thickness, in micrometres, of the dry coating and the method of measurement used in ISO 2808, and whether it is a single coating or a multi-coat system (see [7.4](#));
- d) the temperature and relative humidity during the test, if different from those specified in [8.1.1](#);
- e) the type of cutting tool used and the method of operation (manual or motor-driven);
- f) details of the method used to remove loose paint (see [Annex A](#));
- g) the results of the test, as indicated in [Clause 9](#);
- h) any deviations from the procedure specified;
- i) any unusual features (anomalies) observed during the test;
- j) the date of the test.

Annex A (informative)

Examples of suitable procedures for removing loose paint

A.1 Brushing

Brush the panel lightly with a soft brush several times backwards and several times forwards along each of the diagonals of the lattice pattern.

A.2 Using pressure-sensitive adhesive tape

Place the centre of the tape over the lattice in a direction parallel to one set of cuts as shown in [Figure A.1](#) and smooth the tape into place over the area of the lattice.

To ensure good contact with the coating, rub the tape firmly with a fingertip or fingernail.

Within 5 min after applying the tape, remove the tape by grasping the free end and pulling it off steadily in 0,5 s to 1,0 s at an angle which is as close as possible to 60° (see [Figure A.1](#)).

NOTE The operation of applying and removing the tape can be carried out more than once, depending on the kind of coating and cutting direction.

When testing coatings on plastics substrates the back side of the adhesive tape after pull off can be evaluated visually for any potential residues of the substrate. This practice can be used as a screening test for the correct cross-cut tool (see also [5.2.1](#) and [6.2.3](#)).

A.3 Using compressed air or nitrogen

Remove any loose paint with compressed air or nitrogen.

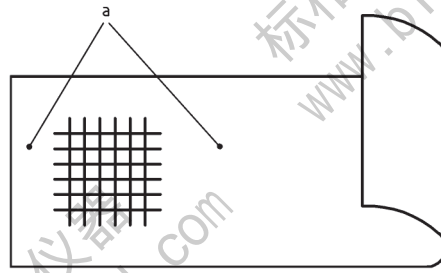

a) Position of adhesive tape with respect to grid

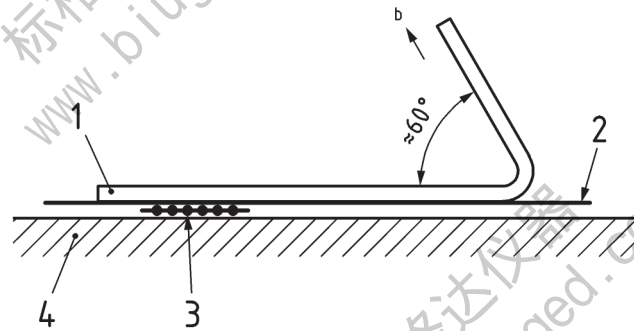

b) Position immediately prior to removal from grid

Key

- 1 tape
- 2 coating
- 3 cuts
- 4 substrate
- a Smoothed down.
- b Direction of removal.

Figure A.1 — Positioning of adhesive tape

Bibliography

- [1] ISO 4624, *Paints and varnishes — Pull-off test for adhesion*
- [2] ISO 16276-2, *Corrosion protection of steel structures by protective paint systems — Assessment of, and acceptance criteria for, the adhesion/cohesion (fracture strength) of a coating — Part 2: Cross-cut testing and X-cut testing*