

BRITISH STANDARD

BS EN ISO  
2811-4:2001  
BS 3900-A22:  
1998

*Incorporating  
Amendment No. 1 to  
BS 3900-A22:1998  
(renumbers the BS as  
BS EN ISO 2811-4: 2001)  
and incorporating  
Corrigendum No. 1*

# Paints and varnishes — Determination of density —

## Part 4: Pressure cup method

The European Standard EN ISO 2811-4:2001 has the status of a  
British Standard

ICS 87.040

NO COPYING WITHOUT BSI PERMISSION EXCEPT AS PERMITTED BY COPYRIGHT LAW



## National foreword

This British Standard is the official English language version of EN ISO 2811-4:2001. It is identical with ISO 2811-4:1997.

The UK participation in its preparation was entrusted to Technical Committee STI/10, Test methods for paints, which has the responsibility to:

- aid enquirers to understand the text;
- present to the responsible international/European committee any enquiries on the interpretation, or proposals for change, and keep the UK interests informed;
- monitor related international and European developments and promulgate them in the UK

A list of organizations represented on this committee can be obtained on request to its secretary.

### Cross-references

The British Standards which implement international or European publications referred to in this document may be found in the BSI Standards Catalogue under the section entitled "International Standards Correspondence Index", or by using the "Find" facility of the BSI Standards Electronic Catalogue.

A British Standard does not purport to include all the necessary provisions of a contract. Users of British Standards are responsible for their correct application.

**Compliance with a British Standard does not of itself confer immunity from legal obligations.**

### Summary of pages

This document comprises a front cover, an inside front cover, the EN ISO title page, the EN ISO foreword page, the ISO title page, page ii, pages 1 to 8, an inside back cover and a back cover.

The BSI copyright notice displayed in this document indicates when the document was last issued.

This British Standard, having been prepared under the direction of the Sector Board for Materials and Chemicals, was published under the authority of the Standards Board and comes into effect on 15 April 1998

© BSI 19 March 2002

### Amendments issued since publication

Amd. No.	Date	Comments
13284	01 October 2001	Implementation of the European Standard
13751 Corr. No. 1	19 March 2002	Incorporation of Annex ZA

English version

Paints and varnishes — Determination of density —  
Part 4: Pressure cup method

(ISO 2811-4:1997)

Peintures et vernis —  
Détermination de la masse volumique —  
Partie 4: Méthode du cylindre sous pression  
(ISO 2811-4:1997)

Beschichtungsstoffe —  
Bestimmung der Dichte —  
Teil 4: Druckzylinder-Verfahren  
(ISO 2811-4:1997)

This European Standard was approved by CEN on 29 June 2001.

CEN members are bound to comply with the CEN/CENELEC Internal Regulations which stipulate the conditions for giving this European Standard the status of a national standard without any alteration. Up-to-date lists and bibliographical references concerning such national standards may be obtained on application to the Management Centre or to any CEN member

This European Standard exists in three official versions (English, French, German). A version in any other language made by translation under the responsibility of a CEN member into its own language and notified to the Management Centre has the same status as the official versions.

CEN members are the national standards bodies of Austria, Belgium, Czech Republic, Denmark, Finland, France, Germany, Greece, Iceland, Ireland, Italy, Luxembourg, Netherlands, Norway, Portugal, Spain, Sweden, Switzerland and the United Kingdom.

**CEN**

European Committee for Standardization  
Comité Européen de Normalisation  
Europäisches Komitee für Normung

**Management Centre: Rue de Stassart, 36 B-1050 Brussels**

## Foreword

The text of the International Standard from Technical Committee ISO/TC 35, Paints and varnishes, of the International Organization for Standardization (ISO) has been taken over as a European Standard by Technical Committee CEN/TC 139, Paints and varnishes, the Secretariat of which is held by DIN.

This European Standard shall be given the status of a national standard, either by publication of an identical text or by endorsement, at the latest by February 2002, and conflicting national standards shall be withdrawn at the latest by February 2002.

According to the CEN/CENELEC Internal Regulations, the national standards organizations of the following countries are bound to implement this European Standard: Austria, Belgium, Czech Republic, Denmark, Finland, France, Germany, Greece, Iceland, Ireland, Italy, Luxembourg, Netherlands, Norway, Portugal, Spain, Sweden, Switzerland and the United Kingdom.

Licensed Copy: sheffieldun sheffieldun, na, Mon Nov 20 03:02:04 GMT+00:00 2006, Uncontrolled Copy, (c) BSI

# INTERNATIONAL STANDARD

**ISO  
2811-4**

First edition  
1997-12-15

---

## **Paints and varnishes — Determination of density —**

### **Part 4: Pressure cup method**

*Peintures et vernis — Détermination de la masse volumique —*

*Partie 4: Méthode du cylindre sous pression*



Reference number  
ISO 2811-4:1997(E)

## Foreword

ISO (the International Organization for Standardization) is a worldwide federation of national standards bodies (ISO member bodies). The work of preparing International Standards is normally carried out through ISO technical committees. Each member body interested in a subject for which a technical committee has been established has the right to be represented on that committee. International organizations, governmental and non-governmental, in liaison with ISO, also take part in the work. ISO collaborates closely with the International Electrotechnical Commission (IEC) on all matters of electrotechnical standardization.

Draft International Standards adopted by the technical committees are circulated to the member bodies for voting. Publication as an International Standard requires approval by at least 75 % of the member bodies casting a vote.

International Standard ISO 2811-4 was prepared by Technical Committee ISO/TC 35, *Paints and varnishes*, Subcommittee SC 9, *General test methods for paints and varnishes*.

Together with the other parts, this part of ISO 2811 cancels and replaces ISO 2811:1974, which has been technically revised.

ISO 2811 consists of the following parts, under the general title *Paints and varnishes — Determination of density*:

- Part 1: *Pyknometer method*;
- Part 2: *Immersed body (plummet) method*;
- Part 3: *Oscillation method*;
- Part 4: *Pressure cup method*.

Annex A forms an integral part of this part of ISO 2811. Annex B is for information only.

**Descriptors:** Paints, varnishes, tests, determination, density (mass/volume), density measurement.

## 1 Scope

This part of ISO 2811 is one of a series of standards dealing with the sampling and testing of paints, varnishes and related products.

It specifies a method for determining the density of paints, varnishes and related products using a pressure cup.

The method is suitable for products which are aerated. Emulsion paints, for example, often trap small air bubbles and these may still be present when the density is measured.

It is not however suitable for textured paints which contain coarse particles.

## 2 Normative references

The following standards contain provisions which, through reference in this text, constitute provisions of this part of ISO 2811. At the time of publication, the editions indicated were valid. All standards are subject to revision, and parties to agreements based on this part of ISO 2811 are encouraged to investigate the possibility of applying the most recent editions of the standards indicated below. Members of IEC and ISO maintain registers of currently valid International Standards.

ISO 1512:1991, *Paints and varnishes — Sampling of products in liquid or paste form.*

ISO 1513:1992, *Paints and varnishes — Examination and preparation of samples for testing.*

ISO 3696:1987, *Water for analytical laboratory use — Specification and test methods.*

## 3 Definition

For the purposes of this part of ISO 2811, the following definition applies.

### 3.1

**density,  $\rho$**

the mass divided by the volume of a portion of a material, expressed in grams per millilitre (g/ml)

## 4 Principle

The product under test is compressed in a cylindrical pressure cup to reduce any error due to air bubbles which have not been eliminated. The density is calculated from the mass of the product and the volume of the cylinder.

NOTE Air is more soluble at higher pressures, and it is thought that the main mechanism of bubble removal is by dissolving. Any undissolved bubbles are compressed to a fraction of their original size.

## 5 Temperature

The effect of temperature on density is highly significant with respect to filling properties, and varies with the type of product.

For international reference purposes, it is essential to standardize one test temperature, and  $(23 \pm 0,5) ^\circ\text{C}$  is specified in this part of ISO 2811. However, it may be more convenient to carry out comparative testing at some other agreed temperature, for example  $(20 \pm 0,5) ^\circ\text{C}$  as specified by relevant weights and measures legislation (see also Annex B, clause B.2).

The test sample and pressure cup shall be conditioned to the specified or agreed temperature, and it shall be ensured that the temperature variation does not exceed  $0,5 ^\circ\text{C}$  during testing.

## 6 Apparatus

Ordinary laboratory apparatus and glassware, together with the following:

**6.1 Pressure cup**, comprising a hollow cylinder closed by a screw-driven piston at its lower end and by a pressure-release cap at the top (see Figure 1). A calibration collar on the screw is set to stop further movement of the piston when the volume contained in the cylinder is 100 ml. The pressure-release cap is designed to let liquid escape when the pressure in the cylinder rises above  $(1 \pm 0,1) \text{ MPa}$  (10 bar). The apparatus is made of a strong, inert material, for example stainless steel, and it is easily dismantled for cleaning.

**6.2 Thermometer**, accurate to 0,2 °C and graduated at intervals of 0,2 °C or finer.

**6.3 Temperature-controlled chamber**, capable of maintaining the pressure cup and sample at the specified or agreed temperature (see clause 5).

**6.4 Balance**, accurate to 10 mg.

## 7 Sample

Take a representative sample of the product to be tested, as described in ISO 1512. Examine and prepare the sample as described in ISO 1513.

## 8 Procedure

### 8.1 General

Carry out the determination in duplicate, each time on a fresh test sample.

### 8.2 Determination

Weigh the apparatus dismantled, ensure that it is clean and has a trace of grease on the moving parts. Fit the piston in its lowest position in the cylinder.

Weigh the complete apparatus to the nearest 10 mg ( $m_1$ ). Bring the apparatus and the test sample to the specified or agreed temperature by placing it next to the balance for at least 30 min.

Pour the test sample into the cylinder until it is almost full, and allow sufficient time for the test sample and the cylinder to come to equilibrium at the test temperature. Confirm that the temperature is correct using the thermometer (6.2). Secure the pressure-release cap in position, in accordance with the manufacturer's instructions.

Compress the test sample by turning the screw. As the pressure reaches 1 MPa, excess paint is forced out between the cylinder and the cap. Continue turning the screw until the calibration collar stops further movement.

NOTE A rag held around the top of the cylinder will reduce the mess. It is essential that some excess paint is forced out, to confirm that full pressure is achieved.

Clean and dry the outside of the filled cup, and weigh it to the nearest 10 mg ( $m_2$ ).

Unscrew the piston enough to reduce the pressure. Dismantle, empty and clean the apparatus.

For reference tests, and periodically during routine tests, check the calibration of the apparatus, using pure water as the test liquid (see Annex A).

## 9 Calculation

Calculate the density  $\rho$  of the product, in grams per millilitre, at the test temperature  $t_T$  using the following equation:

$$\rho = \frac{m_2 - m_1}{V_t}$$

where

$m_1$  is the mass, in grams, of the empty pressure cup;

$m_2$  is the mass, in grams, of the pressure cup filled with the product at the test temperature  $t_T$ ;

$V_t$  is the volume, in millilitres, of the pressure cup at the test temperature  $t_T$ , determined in accordance with Annex A.

NOTE The result is not corrected for air buoyancy because the uncorrected value is required by most filling-machine control procedures and the correction (0,001 2 g/ml) is negligible in relation to the precision of the method.



## 10 Precision

### 10.1 Repeatability (r)

The value below which the absolute difference between two single test results, each the mean of duplicates, obtained on identical material by one operator in one laboratory within a short interval of time using the standardized test method may be expected to lie with a 95 % probability is 0,005 g/ml.

### 10.2 Reproducibility (R)

No data is currently available.

## 11 Test report

The test report shall include at least the following information:

- a) all details necessary to identify the product tested;
- b) a reference to this part of ISO 2811 (i.e. ISO 2811-4);
- c) the supplier and serial number or other identification of the pressure cup;
- d) the test temperature;
- e) the results of each density measurement and the mean, rounded to the nearest 0,01 g/ml;
- f) any deviation from the test method specified;
- g) the date of the test.

Licensed Copy: sheffieldun sheffieldun, na, Mon Nov 20 03:02:04 GMT+00:00 2006, Uncontrolled Copy, (c) BSI

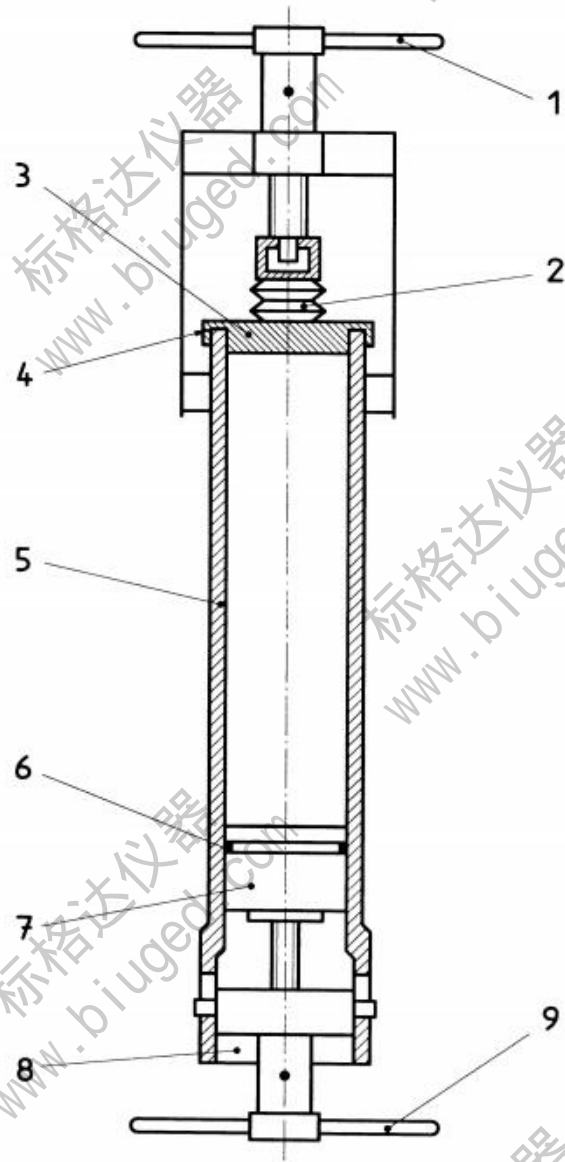

**Key**

- 1) Pressure-setting handle
- 2) Pressure-release device
- 3) End cap
- 4) End seal
- 5) Cylinder (closed volume 100 ml)
- 6) Piston seal
- 7) Piston
- 8) Calibration-collar stop
- 9) Pressure-application handle

**Figure 1 — Pressure cup**

## Annex A (normative)

### Calibration of the pressure cup

#### A.1 Procedure

Put the pressure cup in a container next to the balance in order for it to reach room temperature (approximately 30 min). Then weigh using the balance and record this mass ( $m_1$ ).

Almost fill the pressure cup with previously boiled distilled or deionized water of grade 2 purity as defined in ISO 3696, which has been brought to a temperature of not more than 1 °C below the test temperature. Secure the pressure-release cap in position, in accordance with the manufacturer's instructions.

Place the pressure cup in the temperature-controlled chamber and wait until the test temperature is reached then compress the water by turning the screw. Continue until the calibration collar stops further movement, and wipe off any excess water with an absorbent material (cloth or paper), leaving the pressure cup exactly filled. Take the pressure cup out of the chamber and dry it thoroughly on the outside. Avoid additional heating up. Weigh the filled pressure cup immediately ( $m_3$ ).

NOTE Handle the pressure cup as little as possible to minimize temperature increases.

#### A.2 Calculation of the volume of the pressure cup

Calculate the volume  $V_t$ , in millilitres, of the pressure cup at temperature  $t_T$  using the following equation:

$$V_t = \frac{m_3 - m_1}{\rho_W}$$

where

- $m_1$  is the mass, in grams, of the empty pressure cup;
- $m_3$  is the mass, in grams, of the pressure cup filled with distilled water at the test temperature  $t_T$ ;
- $\rho_W$  is the density, in grams per millilitre, of pure water at the test temperature  $t_T$  (see Table A.1).

Table A.1 — Density of pure, air-free water

Temperature $t_T$ °C	Density $\rho_w$ g/ml	Temperature $t_T$ °C	Density $\rho_w$ g/ml	Temperature $t_T$ °C	Density $\rho_w$ g/ml
10	0,999 7	22	0,997 8	25	0,997 0
11	0,999 6				
12	0,999 5	22,1	0,997 8	25,1	0,997 0
13	0,999 4	22,2	0,997 7	25,2	0,997 0
14	0,999 2	22,3	0,997 7	25,3	0,997 0
15	0,999 1	22,4	0,997 7	25,4	0,996 9
16	0,998 9	22,5	0,997 7	25,5	0,996 9
17	0,998 8	22,6	0,997 6	25,6	0,996 9
18	0,998 6	22,7	0,997 6	25,7	0,996 9
19	0,998 4	22,8	0,997 6	25,8	0,996 8
		22,9	0,997 6	25,9	0,996 8
20	0,998 2	23	0,997 5	26	0,996 8
				27	0,996 5
20,1	0,998 2	23,1	0,997 5	28	0,996 2
20,2	0,998 2	23,2	0,997 5	29	0,995 9
20,3	0,998 1	23,3	0,997 5	30	0,995 7
20,4	0,998 1	23,4	0,997 4	31	0,995 3
20,5	0,998 1	23,5	0,997 4	32	0,995 0
20,6	0,998 1	23,6	0,997 4	33	0,994 7
20,7	0,998 1	23,7	0,997 4	34	0,994 4
20,8	0,998 0	23,8	0,997 3	35	0,994 0
20,9	0,998 0	23,9	0,997 3		
21	0,998 0	24	0,997 3	36	0,993 7
				37	0,993 3
21,1	0,998 0	24,1	0,997 3	38	0,993 0
21,2	0,998 0	24,2	0,997 2	39	0,992 6
21,3	0,997 9	24,3	0,997 2	40	0,992 2
21,4	0,997 9	24,4	0,997 2		
21,5	0,997 9	24,5	0,997 2		
21,6	0,997 9	24,6	0,997 1		
21,7	0,997 8	24,7	0,997 1		
21,8	0,997 8	24,8	0,997 1		
21,9	0,997 8	24,9	0,997 1		

## Annex B (informative) Temperature variation

### B.1 Correction for thermal expansion of the pressure cup

If the test temperature  $t_T$  differs by more than 5 °C from the temperature at which the volume of the pressure cup is known, then the density should preferably be corrected for the change in volume of the pressure cup.

Calculate, to five significant figures, the volume  $V_t$ , in millilitres, of the pressure cup at the test temperature using the following equation:

$$V_t = V_C [1 + \gamma_P (t_T - t_C)]$$

where

$V_C$  is the volume, in millilitres, of the pressure cup at the calibration  $t_C$ ;

$t_T$  is the test temperature, in degrees Celsius;

$t_C$  is the calibration temperature, in degrees Celsius;

$\gamma_P$  is the volume coefficient of thermal expansion, in reciprocal degrees Celsius (°C<sup>-1</sup>), of the material from which the pressure cup is made (see Table B.1).

**Table B.1 — Coefficient of thermal expansion  $\gamma_P$  of material used for pressure cups**

Material	$\gamma_P$ °C <sup>-1</sup>
Austenitic stainless steel	$48 \times 10^{-6}$

### B.2 Calculation of density at reference temperature from measurements at any temperature

If the density of the product under test is determined at a temperature different from the reference temperature the density  $\rho_C$ , in grams per millilitre, at the reference temperature can be calculated as follows:

$$\rho_C = \frac{\rho_t}{[1 + \gamma_m (t_C - t_T)]} = \rho_t [1 - \gamma_m (t_C - t_T)]$$

where

$t_C$  is the reference temperature, in degrees Celsius;

$t_T$  is the test temperature, in degrees Celsius;

$\gamma_m$  is the volume coefficient of thermal expansion of the product under test, the approximate value of  $\gamma_m$  being  $2 \times 10^{-4}$  °C<sup>-1</sup> for waterborne paints and  $7 \times 10^{-4}$  °C<sup>-1</sup> for other paints;

$\rho_t$  is the density, in grams per millilitre, of the product at the test temperature.

**Annex ZA (normative)****Normative references to international publications with their relevant European publications**

This European Standard incorporates by dated or undated reference, provisions from other publications. These normative references are cited at the appropriate places in the text and the publications are listed hereafter. For dated references, subsequent amendments to or revisions of any of these publications apply to this European Standard only when incorporated in it by amendment or revision. For undated references the latest edition of the publication referred to applies (including amendments).

NOTE Where an International Publication has been modified by common modifications, indicated by (mod.), the relevant EN/HD applies.

Publication	Year	Title	EN	Year
ISO 1513	1992	<i>Paints and varnishes — Examination and preparation for samples for testing</i>	EN ISO 1513	1994
ISO 3696	1997	<i>Water for analytical laboratory use — Specification and test methods</i>	EN ISO 3696	1995

标格达仪器  
www.biuged.com

标格达仪器  
www.biuged.com

标格达仪器  
www.biuged.com

标格达仪器  
www.biuged.com

标格达仪器  
www.biuged.com

标格达仪器  
www.biuged.com

标格达仪器  
www.biuged.com

标格达仪器  
www.biuged.com

标格达仪器  
www.biuged.com

标格达仪器  
www.biuged.com