

INTERNATIONAL
STANDARD

ISO
15184

Third edition
2020-01

**Paints and varnishes — Determination
of film hardness by pencil test**

*Peintures et vernis — Détermination de la dureté du feuil par l'essai
de dureté crayon*



Reference number
ISO 15184:2020(E)

© ISO 2020

标格达仪器
www.biuged.com

标格达仪器
www.biuged.com

标格达仪器
www.biuged.com

标格达仪器
www.biuged.com

标格达仪器
www.biuged.com

标格达仪器
www.biuged.com

标格达仪器
www.biuged.com



COPYRIGHT PROTECTED DOCUMENT

© ISO 2020

All rights reserved. Unless otherwise specified, or required in the context of its implementation, no part of this publication may be reproduced or utilized otherwise in any form or by any means, electronic or mechanical, including photocopying, or posting on the internet or an intranet, without prior written permission. Permission can be requested from either ISO at the address below or ISO's member body in the country of the requester.

ISO copyright office
CP 401 • Ch. de Blandonnet 8
CH-1214 Vernier, Geneva
Phone: +41 22 749 01 11
Fax: +41 22 749 09 47
Email: copyright@iso.org
Website: www.iso.org

Published in Switzerland

Contents

Page

Foreword	iv
1 Scope	1
2 Normative references	1
3 Terms and definitions	1
4 Principle	2
5 Apparatus	2
6 Sampling	3
7 Test panels	3
7.1 Substrate	3
7.2 Shape and dimensions	3
7.3 Preparation and coating	4
7.4 Drying and conditioning	4
7.5 Thickness of coating	4
8 Procedure	4
9 Types of defect	5
10 Precision	5
11 Test report	5
Annex A (informative) Applicability of the pencil hardness test	6

Foreword

ISO (the International Organization for Standardization) is a worldwide federation of national standards bodies (ISO member bodies). The work of preparing International Standards is normally carried out through ISO technical committees. Each member body interested in a subject for which a technical committee has been established has the right to be represented on that committee. International organizations, governmental and non-governmental, in liaison with ISO, also take part in the work. ISO collaborates closely with the International Electrotechnical Commission (IEC) on all matters of electrotechnical standardization.

The procedures used to develop this document and those intended for its further maintenance are described in the ISO/IEC Directives, Part 1. In particular, the different approval criteria needed for the different types of ISO documents should be noted. This document was drafted in accordance with the editorial rules of the ISO/IEC Directives, Part 2 (see www.iso.org/directives).

Attention is drawn to the possibility that some of the elements of this document may be the subject of patent rights. ISO shall not be held responsible for identifying any or all such patent rights. Details of any patent rights identified during the development of the document will be in the Introduction and/or on the ISO list of patent declarations received (see www.iso.org/patents).

Any trade name used in this document is information given for the convenience of users and does not constitute an endorsement.

For an explanation of the voluntary nature of standards, the meaning of ISO specific terms and expressions related to conformity assessment, as well as information about ISO's adherence to the World Trade Organization (WTO) principles in the Technical Barriers to Trade (TBT) see www.iso.org/iso/foreword.html.

This document was prepared by Technical Committee ISO/TC 35, *Paints and varnishes*, Subcommittee SC 9, *General test methods for paints and varnishes*.

This third edition cancels and replaces the second edition (ISO 15184:2012), of which it constitutes a minor revision. The main changes compared to the previous edition are as follows:

- In 5.1 the force of the instrument on the paint surface has been corrected to $(7,35 \pm 0,15) \text{ N}$;
- In 8.6 the statement in that by agreement, the test may also be carried out to determine the minimum pencil hardness which does not cause a cohesive fracture (the so-called "gouge" hardness) has been deleted to avoid confusion with those standards, where this test method is described;
- The text has been editorially revised and the normative references have been updated.

Any feedback or questions on this document should be directed to the user's national standards body. A complete listing of these bodies can be found at www.iso.org/members.html.

Paints and varnishes — Determination of film hardness by pencil test

IMPORTANT — The electronic file of this document contains colours which are considered to be useful for the correct understanding of the document. Users should therefore consider printing this document using a colour printer.

1 Scope

This document specifies a method for determining the film hardness by pushing pencils of known hardness over the film.

The test can be performed on a single coating of a paint, varnish or related product, or on the upper layer of a multi-coat system.

This rapid test has not been found to be useful in comparing the pencil hardness of different coatings. It is more useful in providing relative ratings for a series of coated panels exhibiting significant differences in pencil hardness.

The method is applicable only to smooth surfaces.

2 Normative references

The following documents are referred to in the text in such a way that some or all of their content constitutes requirements of this document. For dated references, only the edition cited applies. For undated references, the latest edition of the referenced document (including any amendments) applies.

ISO 1513, *Paints and varnishes — Examination and preparation of test samples*

ISO 1514, *Paints and varnishes — Standard panels for testing*

ISO 2808, *Paints and varnishes — Determination of film thickness*

ISO 4618, *Paints and varnishes — Terms and definitions*

ISO 15528, *Paints, varnishes and raw materials for paints and varnishes — Sampling*

3 Terms and definitions

For the purposes of this document, the terms and definitions given in ISO 4618 and the following apply.

ISO and IEC maintain terminological databases for use in standardization at the following addresses:

— ISO Online browsing platform: available at <https://www.iso.org/obp>

— IEC Electropedia: available at <http://www.electropedia.org/>

3.1

pencil hardness

resistance of the surface of a paint film to marking, or the formation of some other defect, as a result of the action of a pencil, with a lead of specified dimensions, shape and hardness, which is pushed across the surface

4 Principle

A pencil lead with a defined geometry is pushed over the paint surface at an angle of 45°, exerting a force of $(7,35 \pm 0,15)$ N on the surface. The hardness of the pencil lead is increased in steps until the surface of the coating is marked by visible defects. The test result is the highest hardness at which no marking occurs.

5 Apparatus

5.1 Test instrument, consisting of a metal block fitted with two wheels, one on each side, as shown in [Figure 1](#). The wheels shall be made in such a way that they do not scratch the paint surface during testing. In the middle of the metal block, there is a cylindrical hole, inclined at an angle of $(45 \pm 1)^\circ$, for the pencil.

With the help of a clamp, pencils can be fixed in the instrument so that they are always in the same position.

Mounted on the top of the instrument is a level which is used to ensure that the test is carried out with the instrument horizontal.

The instrument shall be designed so that, with the instrument in the horizontal position, the tip of the pencil exerts a force of $(7,35 \pm 0,15)$ N on the paint surface.

Other types of test instrument may also be used, provided they give similar relative rating results.

5.2 Set of wooden drawing pencils, of the following hardnesses (see note):

9B - 8B - 7B - 6B - 5B - 4B - 3B - 2B - B - HB - F - H - 2H - 3H - 4H - 5H - 6H - 7H - 8H - 9H			
Softer	-----		Harder
B - black	HB - hard black	F - firm	H - hard

Pencils made by various manufacturers may be used by agreement between the interested parties, provided they give similar relative rating results.

NOTE Some examples of pencil makes and manufacturers which have been found suitable are as follows¹⁾:

- Cleos Fine Art 160, manufactured by Cretacolor;
- Graphic, manufactured by Derwent;
- Turquoise T-2375, manufactured by Sanford;
- KOH-I-NOOR 1500, manufactured by Hardtmuth AG;
- Uni, manufactured by Mitsubishi Pencil Co., Ltd.;
- Chunghwa, manufactured by China First Pencil Co., Ltd.

For comparative testing, it is recommended that pencils from the same manufacturer be used. Variations might be found between manufacturers and between batches from the same manufacturer.

Pencil leads in mechanical holders (propelling/mechanical pencils) may be used provided they give the same results as wooden pencils.

5.3 Special mechanical sharpener, which will remove the wood only, leaving the cylindrical pencil lead intact (see [Figure 2](#)).

1) This information is given for the convenience of users of this document and does not constitute an endorsement by ISO of these products.

5.4 **Abrasive paper**, grit No. 400.

5.5 **Soft cloth** or **swab of cotton wool**, to clean the panel after the test, using a solvent to which the coating is inert.

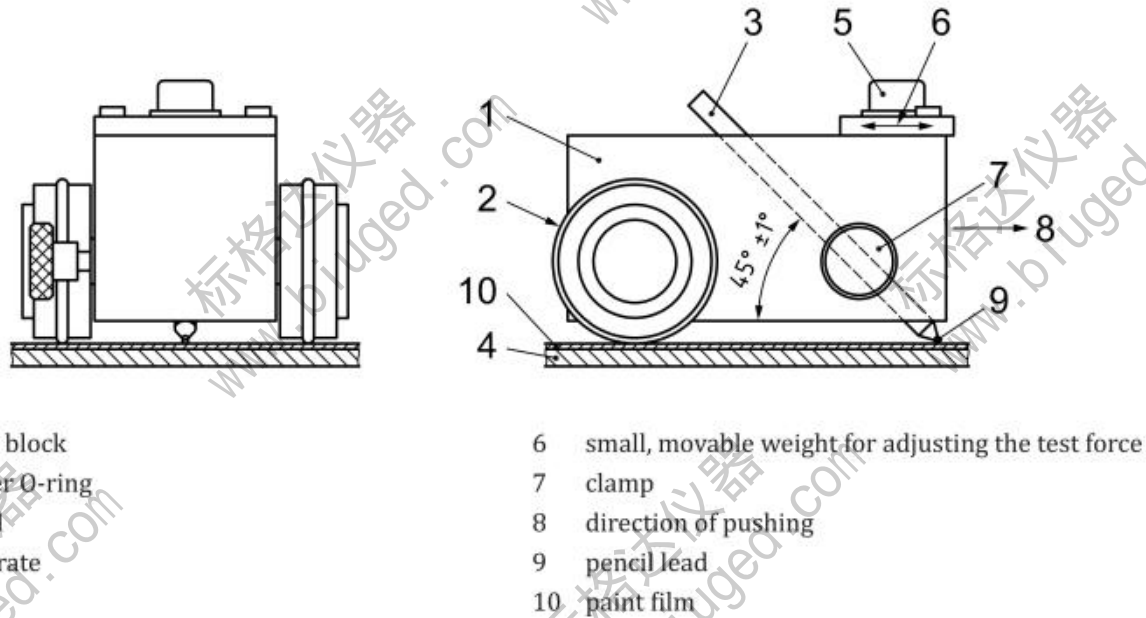

Figure 1 — Schematic diagram of test instrument

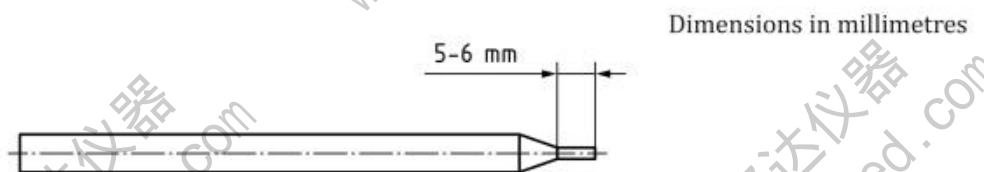

Figure 2 — Schematic view of pencil after sharpening

6 Sampling

Take a representative sample of the product to be tested (or of each product in the case of a multi-coat system), as specified in ISO 15528.

Examine and prepare each sample for testing, as specified in ISO 1513.

7 Test panels

7.1 Substrate

Unless otherwise agreed, select the substrate from one of those specified in ISO 1514, using, where possible, the same type of material as will be used in practice. The substrate panels shall be plane and free from distortion.

7.2 Shape and dimensions

The shape and dimensions of the test panels shall be such that, during the test, the panel will stay in the horizontal position.

7.3 Preparation and coating

Unless otherwise agreed, prepare each test panel in accordance with ISO 1514 and then coat it by the specified method with the product or system under test.

7.4 Drying and conditioning

Dry (or stove) and age, if applicable, each coated test panel for the specified time under the specified conditions. Before testing, condition the coated panels at (23 ± 2) °C and a relative humidity of (50 ± 5) %, unless otherwise agreed, for a minimum period of 16 h.

7.5 Thickness of coating

The thickness of the coating shall be as specified or as agreed between the interested parties. Determine the thickness of the coating by one of the procedures specified in ISO 2808.

8 Procedure

8.1 Carry out the test at a temperature of (23 ± 2) °C and a relative humidity of (50 ± 5) %, unless otherwise agreed.

8.2 Remove approximately 5 mm to 6 mm of wood from the point of each pencil using the special mechanical sharpener (5.3), being careful to leave an undisturbed, unmarked, smooth cylinder of pencil lead.

8.3 Flatten the tip of the lead by holding the pencil in a vertical position and moving the pencil back and forth over abrasive paper (5.4), maintaining an angle of 90°. Continue until a flat, smooth, circular cross-section is obtained, free from chips or nicks in the edges.

Repeat this procedure each time a pencil is used.

8.4 Place the coated panel on a level, firm, horizontal surface.

Insert a pencil in the test instrument (5.1) and clamp it in position so that the instrument is horizontal, with the tip of the pencil resting on the surface of the paint film (see Figure 1).

8.5 Immediately after the tip of the pencil has come to rest on the coating, push the pencil in the direction away from the operator at a slow constant speed sufficiently long enough to perform a visual interpretation.

8.6 Unless otherwise agreed, inspect the coating after 30 s, using normal corrected vision, for marking of the kind defined in Clause 9.

The damage can be assessed more easily after cleaning all fragments of pencil lead from the paint surface, using a soft cloth or swab of cotton wool (5.5) and an inert solvent. If this is done, take care that the solvent does not affect the hardness of the coating in the test area.

By agreement, a magnifying lens (magnification $\times 6$ to $\times 10$) may be used to assess the damage. If a magnifying lens is used, this shall be reported in the test report.

If no marking has occurred, repeat the test (8.3 to 8.6) without overlap of the test areas, moving up the hardness scale until marking occurs over a distance of at least 3 mm.

If marking has occurred, repeat the test (8.3 to 8.6) down the hardness scale until marking no longer occurs.

Determine which of the defects of the kinds defined in Clause 9 has been produced.

The hardness of the hardest pencil which does not mark the coating is the so-called pencil hardness.

8.7 Carry out the test in duplicate. If the two results differ by more than one unit of pencil hardness, discard them and repeat the test.

9 Types of defect

Marking by pencil leads covers a range of defects in the surface of the paint film.

These defects are defined as follows:

- a) Plastic deformation: a permanent indentation in the paint surface without cohesive fracture.
- b) Cohesive fracture: the presence of a visible scratch or rupture in the surface of the paint film, material having been removed from the paint film.
- c) Combinations of the above.

These defects can occur simultaneously.

10 Precision

No precision data are available.

NOTE The applicability of the method is discussed in [Annex A](#).

11 Test report

The test report shall contain at least the following information:

- a) all details necessary to identify the product tested;
- b) a reference to this document, i.e. ISO 15184;
- c) details of the preparation of the test panels, including
 - 1) the material and surface preparation of the substrate (see [7.1](#) and [7.2](#)),
 - 2) the method of application of the test coating to the substrate, including the duration and conditions of drying between coats in the case of a multi-coat system (see [7.3](#)),
 - 3) the duration and conditions of drying (or stoving) of the coating, and the conditions of ageing, if applicable, before testing (see [7.4](#)),
 - 4) the thickness, in micrometres, of the dry coating and the method of measurement used from ISO 2808 (see [7.5](#)), and whether it is a single coating or a multi-coat system;
- d) the temperature and relative humidity of the test, if different from those specified in [8.1](#);
- e) the make and manufacturer of the pencils used;
- f) the result of the test, including, if agreed between the interested parties, a description of the kinds of defect defined in [Clause 9](#) which actually occurred;
- g) the magnification of the magnifying lens, if used;
- h) any deviation from the test method specified;
- i) any unusual features (anomalies) observed during the test;
- j) the date of the test.

Annex A (informative)

Applicability of the pencil hardness test

To obtain information on the applicability of the pencil hardness test, four different persons made measurements with each of seven different grades of pencil on nine different coatings. The results of the 28 measurements made on each coating are shown in [Figure A.1](#).

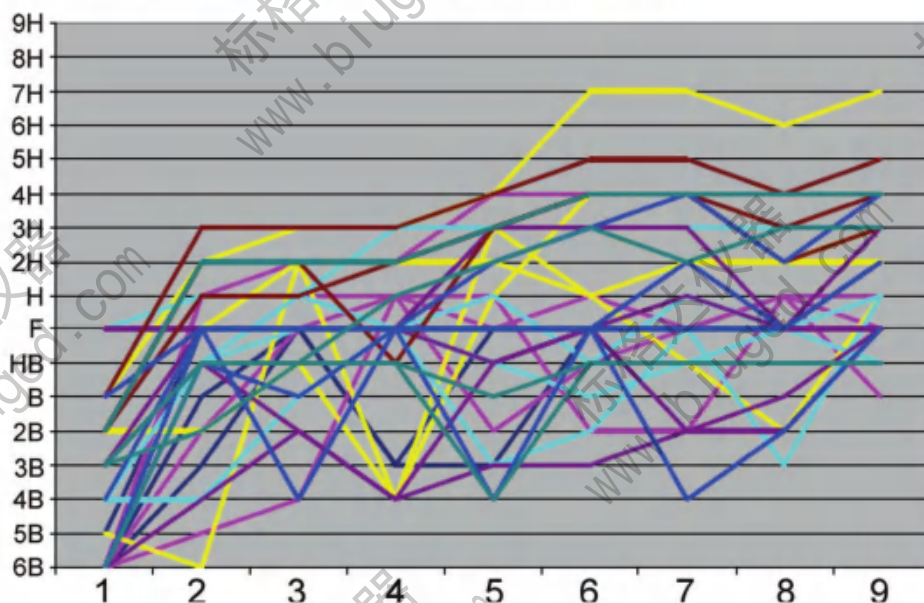

Key
 6B to 9H pencil hardness
 1 to 9 different coatings on which the measurements were made
 Each colour represents a different grade of pencil.
 For a given colour, each line represents a different person.

Figure A.1 — Results of measurements on nine different coatings by four different persons using seven different grades of pencil

The results of the measurements underline the statement in the scope of this document that the pencil hardness test has not been found to be useful in comparing the pencil hardness of different coatings. It is more useful in providing relative ratings for a series of coated panels exhibiting significant differences in pencil hardness.

标格达仪器
www.biuged.com

标格达仪器
www.biuged.com

标格达仪器
www.biuged.com

标格达仪器
www.biuged.com

标格达仪器
www.biuged.com

标格达仪器
www.biuged.com

标格达仪器
www.biuged.com

标格达仪器
www.biuged.com

标格达仪器
www.biuged.com

标格达仪器
www.biuged.com

标格达仪器
www.biuged.com

标格达仪器
www.biuged.com

标格达仪器
www.biuged.com

标格达仪器
www.biuged.com

标格达仪器
www.biuged.com

标格达仪器
www.biuged.com

标格达仪器
www.biuged.com

标格达仪器
www.biuged.com

标格达仪器
www.biuged.com

标格达仪器
www.biuged.com